



REAR LOWER ARM FRAME GUARD

INSTALL WITH HDPE SLIDE FOR **BRONCO & BRONCO RAPTOR**

****RECOMMENDED THIS IS INSTALLED BY A CERTIFIED MECHANIC****
LEVEL: DIFFICULT

PAGE 2

BRONCO HARDWARE ASSEMBLY KEY
& DIAGRAM

PAGE 3

BRONCO HARDWARE ASSEMBLY KEY
& DIAGRAM (CONTINUED)

PAGE 4

BRONCO DRIVERS SIDE DIAGRAM
(WITH ASSEMBLY NOTE)

PAGE 5

BRONCO PASSENGER SIDE DIAGRAM
(WITH ASSEMBLY NOTE)

PAGE 6

BRONCO RAPTOR HARDWARE ASSEMBLY KEY
& DIAGRAM

PAGE 7

BRONCO RAPTOR DRIVERS SIDE DIAGRAM
(WITH ASSEMBLY NOTE)

PAGE 8

BRONCO RAPTOR PASSENGER SIDE
DIAGRAM (WITH ASSEMBLY NOTE)

PAGE 9-12

STEPS FOR PRODUCT INSTALLATION



REAR LOWER ARM FRAME GUARD

INSTALL WITH HDPE SLIDE FOR BRONCO & BRONCO RAPTOR

PAGE 2 - BRONCO HARDWARE ASSEMBLY & DIAGRAM KEY

ITEM NO.	PART NUMBER	DESCRIPTION	QTY.
1	FMI 2020 Bronco rear frame lower arm mount - bottom plastic slider	HDPE plastic slider for Bronco	1
2	90566A029	1/4-20 - Grade 5 - Steel Thin Nylon-Insert Locknut	16
3	92210A540	1/4-20 x 3/4 long - 18-8 Stainless Steel Hex Drive Flat Head Screw	16
4	FMI 2021 Bronco rear frame lower arm mount - outer side spacer plate		1
5	FMI 2021 Bronco rear frame lower arm mount -inside plate welded nut plate assy		1
6	FMI 2021 Bronco rear frame lower arm mount -outside plate welded nut plate assy		1
7	FMI 2021 Bronco rear frame lower arm mount - inside spacer plate		1
8	FMI 2021 Bronco rear frame lower arm mount - main skid plate Driver Side VER 2		1
9	92620A656	3/8-24 x 1.25" Long - Grade 8 - Zinc Yellow-Chromate Plated Hex Head Screw	6
10	90126A031	3/8 - Grade 5 - Zinc-Plated Steel SAE Washer	6
11	MirrorFMI 2020 Bronco rear frame lower arm mount - bottom plastic slider		1
12	MirrorFMI 2021 Bronco rear frame lower arm mount - outer side spacer plate		1
13	MirrorFMI 2021 Bronco rear frame lower arm mount - outside plate welded nut plate assy		1
14	MirrorFMI 2021 Bronco rear frame lower arm mount - main skid plate Driver Side VER 2		1

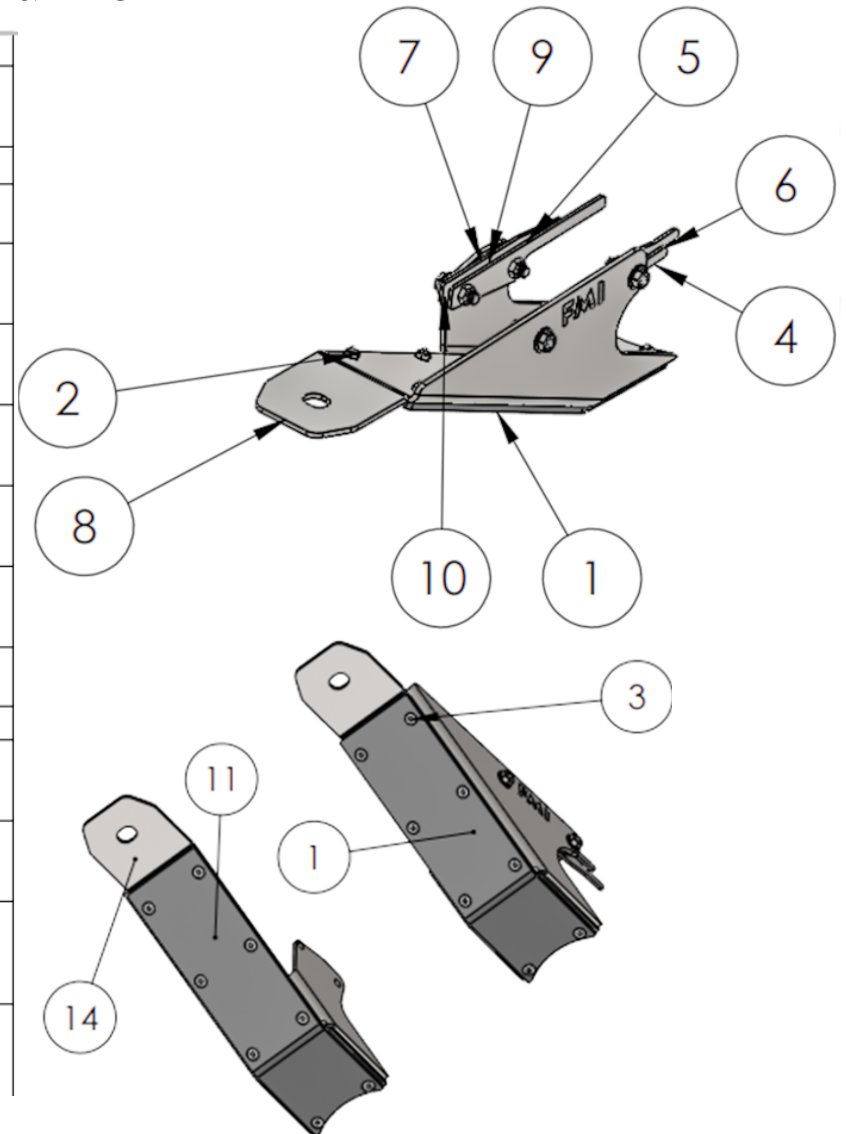



REAR LOWER ARM FRAME GUARD

INSTALL WITH HDPE SLIDE FOR BRONCO & BRONCO RAPTOR

PAGE 3 - BRONCO HARDWARE ASSEMBLY & DIAGRAM KEY (CONT.)

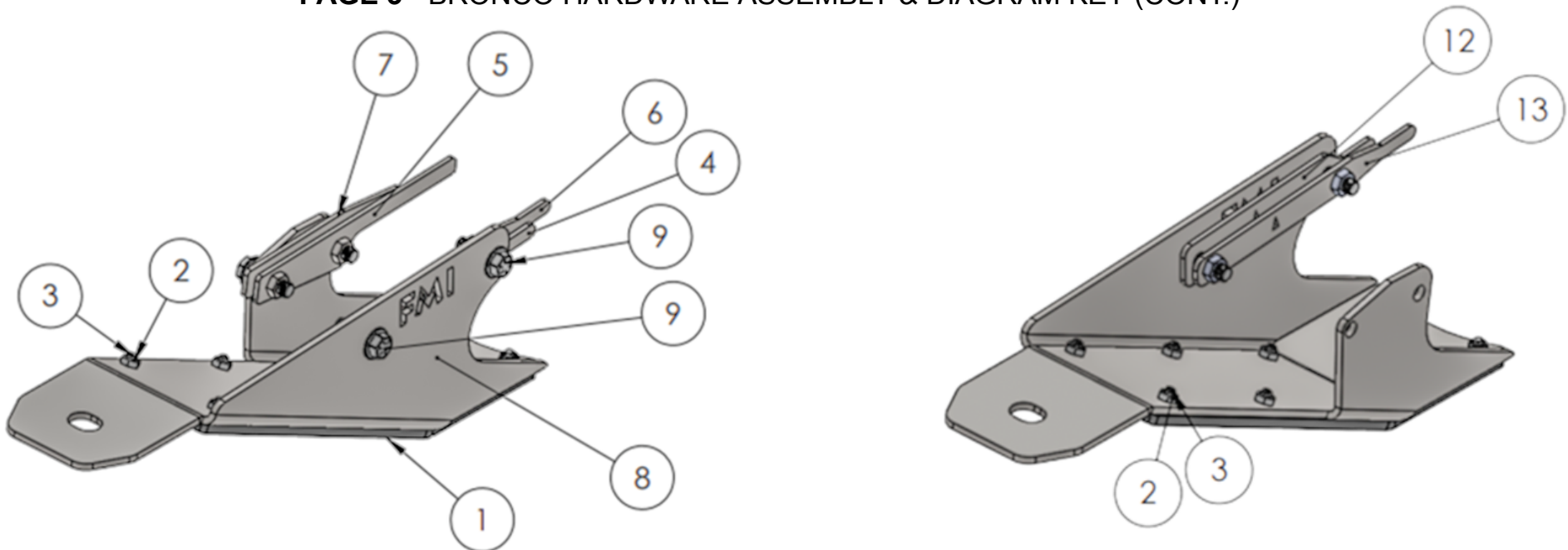

ITEM NO.	PART NUMBER	DESCRIPTION	QTY.
1	FMI 2020 Bronco rear frame lower arm mount - bottom plastic slider	HDPE plastic slider for Bronco	1
2	90566A029	1/4-20 - Grade 5 - Steel Thin Nylon-Insert Locknut	16
3	92210A540	1/4-20 x 3/4 long - 18-8 Stainless Steel Hex Drive Flat Head Screw	16
4	FMI 2021 Bronco rear frame lower arm mount - outer side spacer plate		1
5	FMI 2021 Bronco rear frame lower arm mount -inside plate welded nut plate assy		1
6	FMI 2021 Bronco rear frame lower arm mount -outside plate welded nut plate assy		1
7	FMI 2021 Bronco rear frame lower arm mount - inside spacer plate		1

ITEM NO.	PART NUMBER	DESCRIPTION	QTY.
8	FMI 2021 Bronco rear frame lower arm mount - main skid plate Driver Side VER 2		1
9	92620A656	3/8-24 x 1.25" Long - Grade 8 - Zinc Yellow-Chromate Plated Hex Head Screw	6
10	90126A031	3/8 - Grade 5 - Zinc-Plated Steel SAE Washer	6
11	MirrorFMI 2020 Bronco rear frame lower arm mount - bottom plastic slider		1
12	MirrorFMI 2021 Bronco rear frame lower arm mount - outer side spacer plate		1
13	MirrorFMI 2021 Bronco rear frame lower arm mount - outside plate welded nut plate assy		1
14	MirrorFMI 2021 Bronco rear frame lower arm mount - main skid plate Driver Side VER 2		1



REAR LOWER ARM FRAME GUARD

INSTALL WITH HDPE SLIDE FOR BRONCO & BRONCO RAPTOR

PAGE 4 - BRONCO DRIVERS SIDE DIAGRAM (with assembly notes)

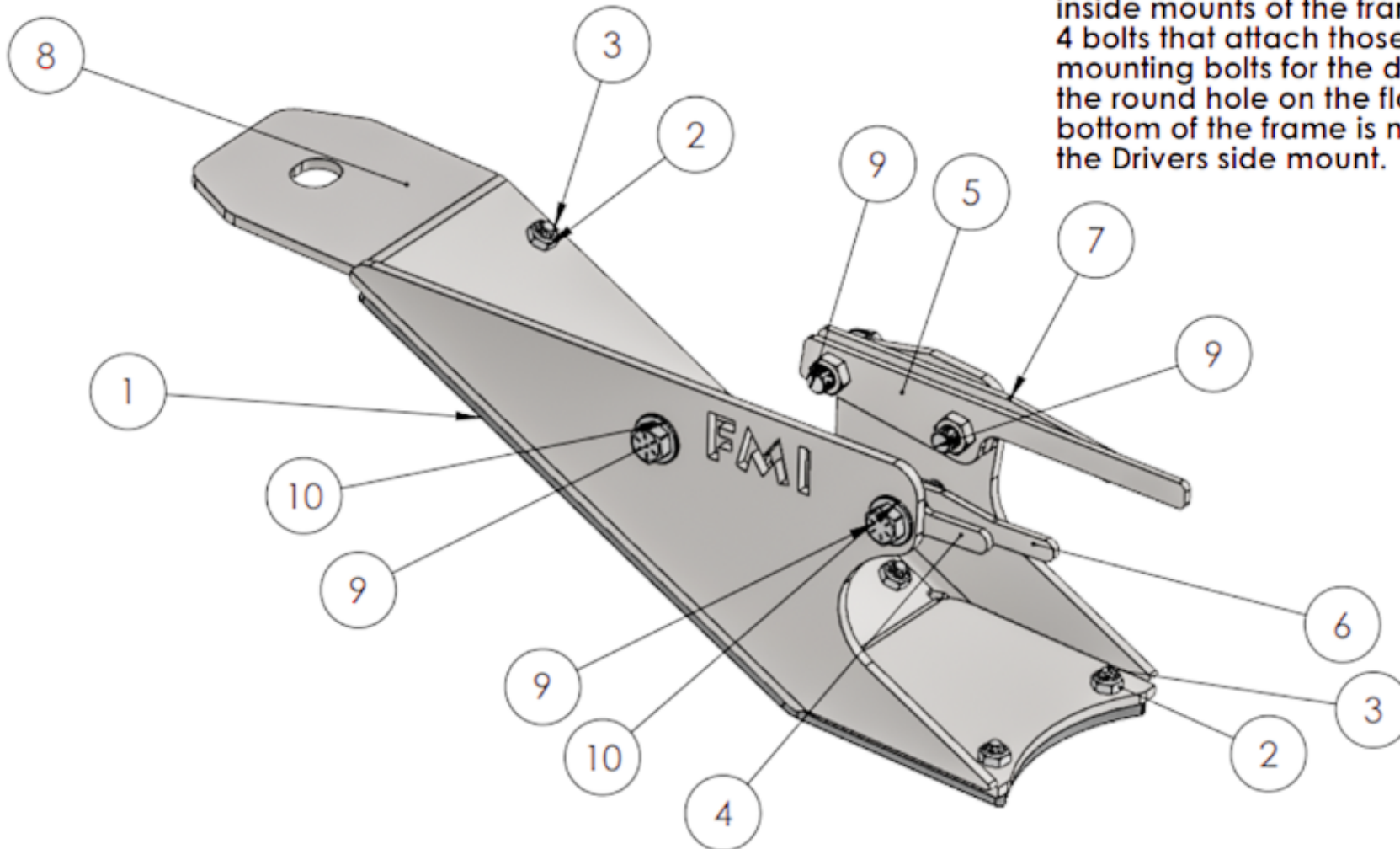

Drivers side frame guard uses the nut plates on the outside and inside mounts of the frame and the 4 bolts that attach those as the only mounting bolts for the drivers side the round hole on the flat tab on the bottom of the frame is not used on the Drivers side mount.



REAR LOWER ARM FRAME GUARD

INSTALL WITH HDPE SLIDE FOR BRONCO & BRONCO RAPTOR

PAGE 5 - BRONCO PASSENGER SIDE DIAGRAM (with assembly notes)

Passenger side frame guard only uses the nut plates on the outside frame mount and the front hole that shares the fuel tank mount bolt on the bottom of the frame of the Bronco. The 2 holes on the inside by the fuel tank are not used

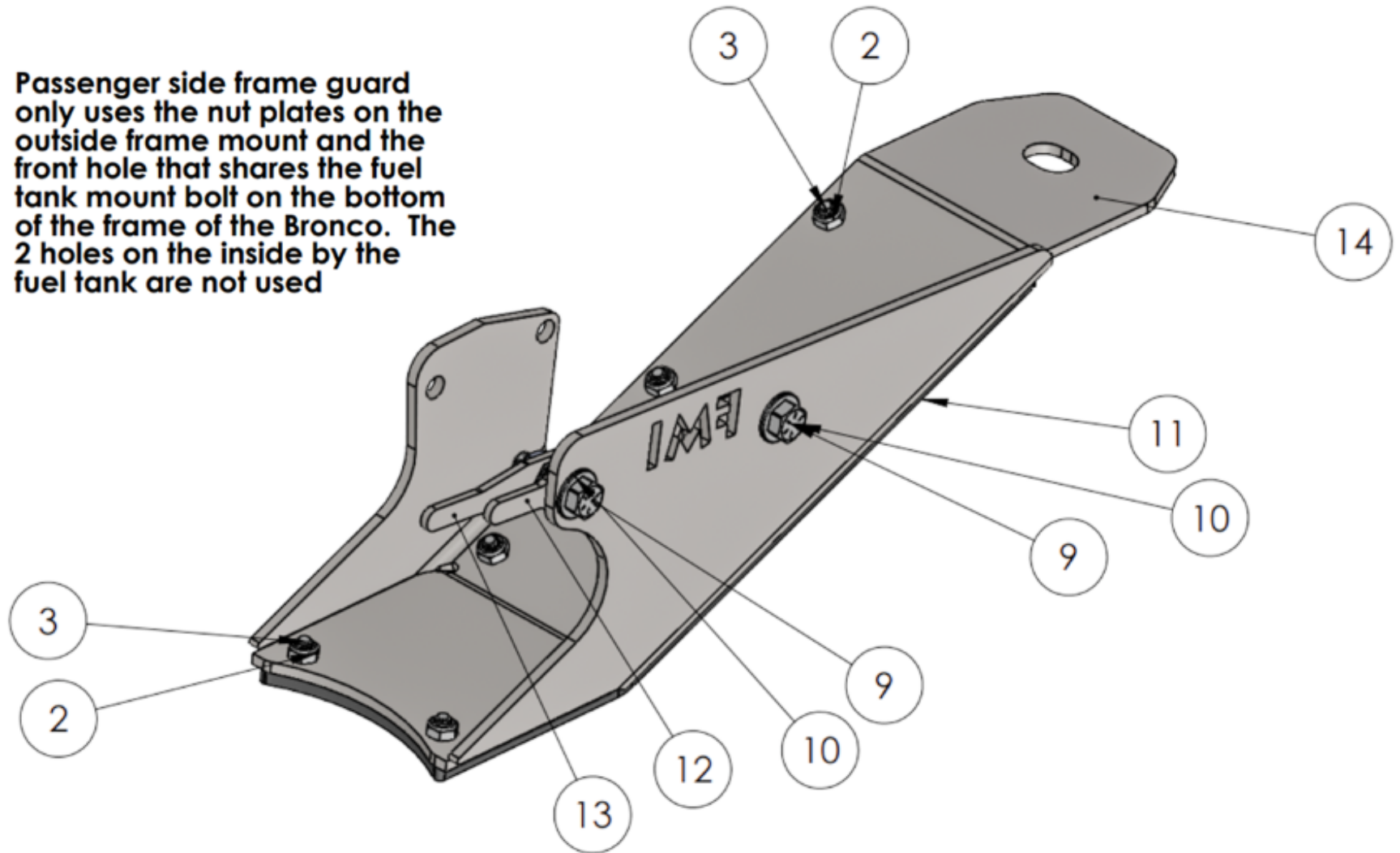



REAR LOWER ARM FRAME GUARD

INSTALL WITH HDPE SLIDE FOR BRONCO & BRONCO RAPTOR

PAGE 6 - BRONCO RAPTOR HARDWARE ASSEMBLY & DIAGRAM

ITEM NO.	PART NUMBER	DESCRIPTION	QTY.
1	FMI 2022 Bronco Raptor rear frame lower arm mount - main skid plate Driver Side		1
2	FMI 2022 Bronco Raptor rear frame lower arm mount - bottom plastic slider		1
3	90566A029	1/4-20 - Grade 5 - Steel Thin Nylon-Insert Locknut	16
4	92210A540	1/4-20 x 3/4 long - 18-8 Stainless Steel Hex Drive Flat Head Screw	16
5	FMI 2022 Bronco Raptor rear frame lower arm mount - inside welded nut plate - Drivers Side - working assy		1
6	FMI 2022 Bronco Raptor rear frame lower arm mount - outside welded nut plate - Drivers Side - working assy		1
7	92620A583	5/16 - 18 x 1" long - Grade 8 - Zinc Yellow-Chromate Plated Hex Head Screw	5
8	98023A030	5/16 - Grade 8 - SAE Washer - Zinc Yellow-Chromate Plated Grade 8 Steel Washer	5
9	MirrorFMI 2022 Bronco Raptor rear frame lower arm mount - main skid plate Driver Side2		1
10	MirrorFMI 2022 Bronco Raptor rear frame lower arm mount - bottom plastic slider1		1
11	94407A105	5/16-18 - Black -18-8 Stainless Steel Nylon-Insert Locknut	1

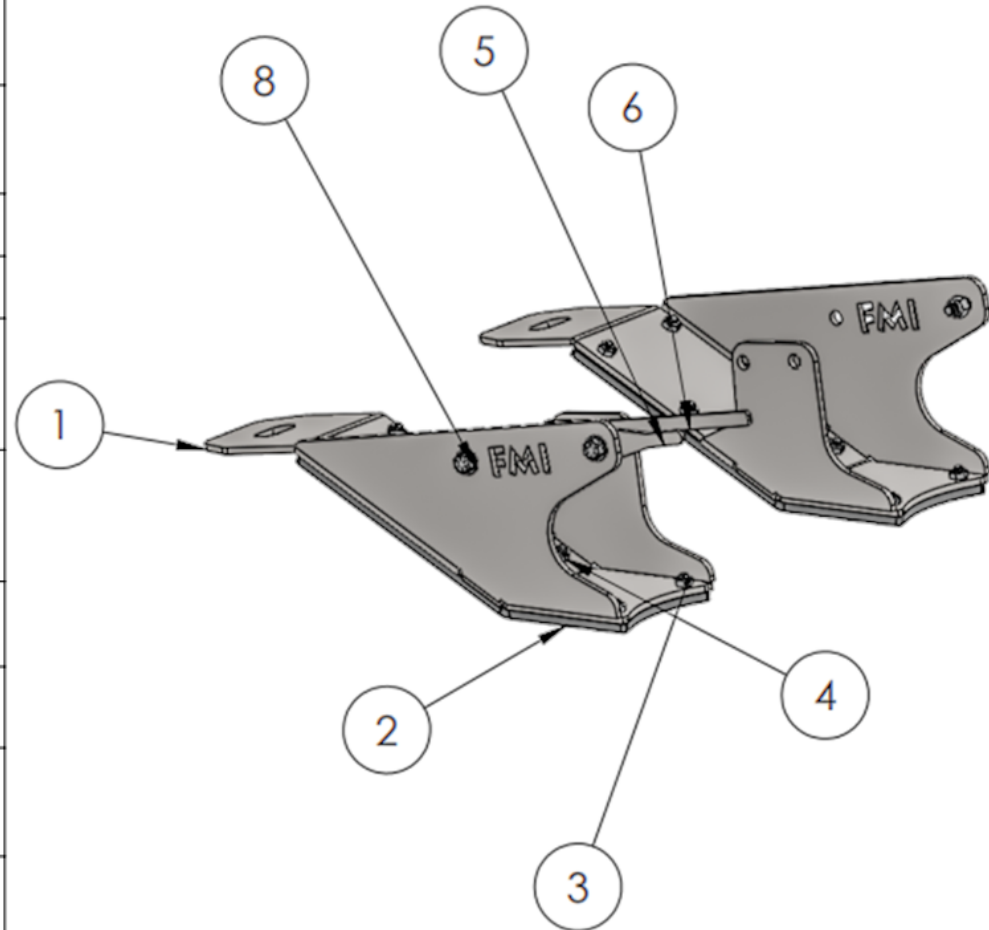



REAR LOWER ARM FRAME GUARD

INSTALL WITH HDPE SLIDE FOR BRONCO & BRONCO RAPTOR

PAGE 7 - BRONCO RAPTOR DRIVER SIDE DIAGRAM (with assembly notes)

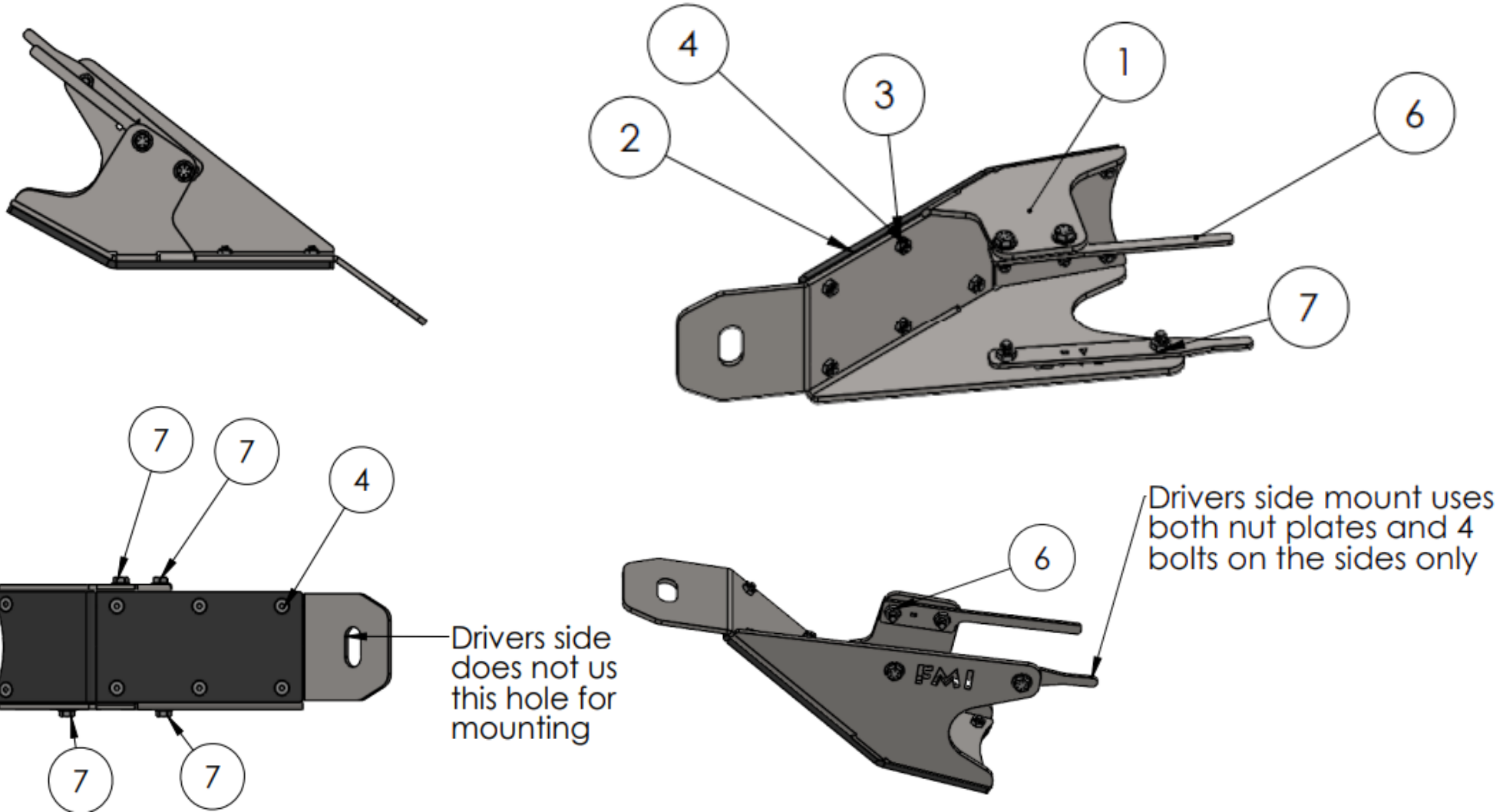



REAR LOWER ARM FRAME GUARD

INSTALL WITH HDPE SLIDE FOR BRONCO & BRONCO RAPTOR

PAGE 8 - BRONCO RAPTOR PASSENGER SIDE DIAGRAM (with assembly notes)

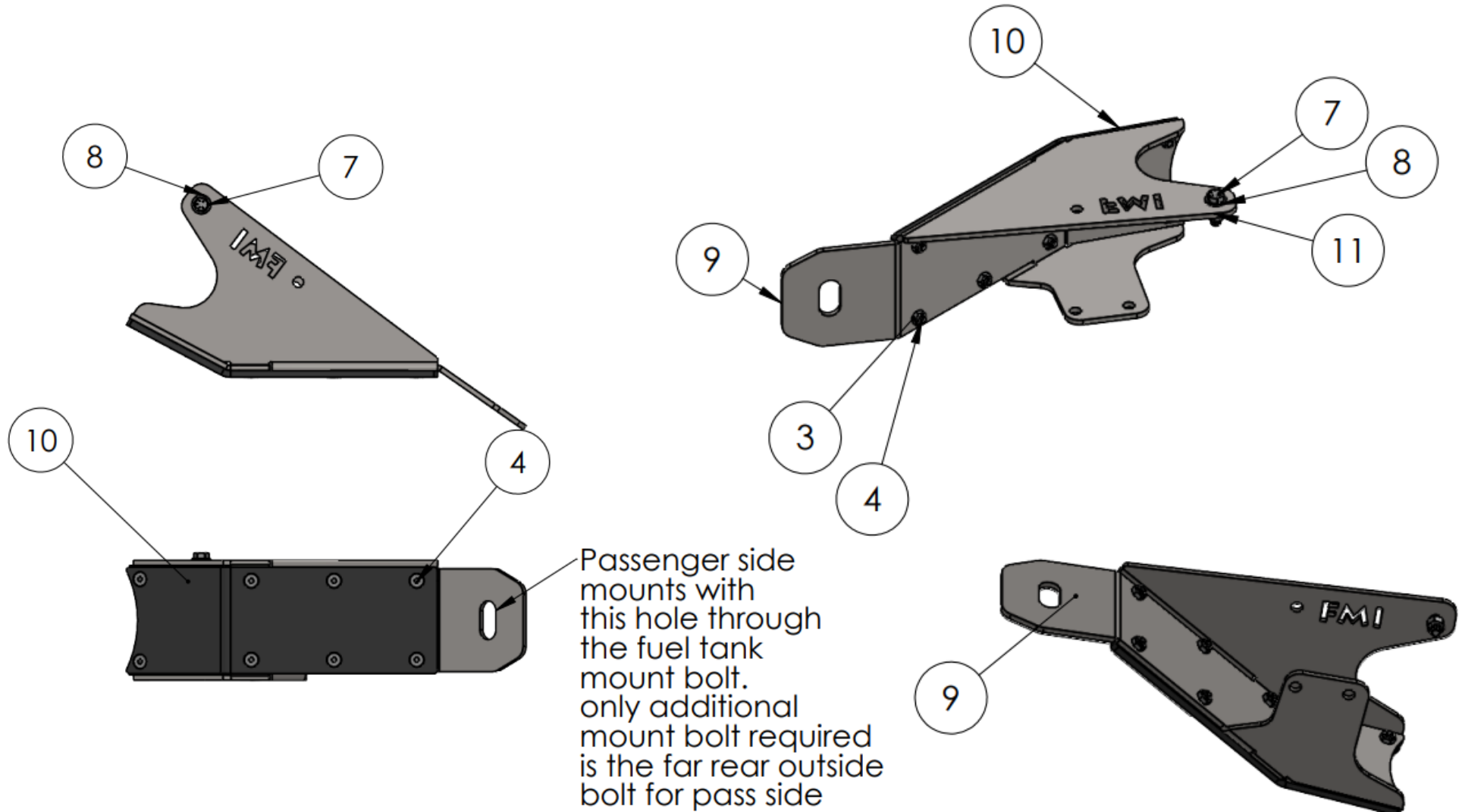



REAR LOWER ARM FRAME GUARD

INSTALL WITH HDPE SLIDE FOR BRONCO & BRONCO RAPTOR

PAGE 9

Step 1:

Starting on the driver's side, remove the nut on the link at the frame. The bolt doesn't need to be completely removed, just only pushed out enough to rotate the flag retainer outside of its hole (the hole is needed to secure the guard) The flag will rest against the mount itself out of the way of the link and the guard.

Step 2:

With the flag out of the way, the guard can be positioned over the link mount, the supplied spacers need to be installed between the guard and the frame.

Then install the supplied nut plates inside the pocket, securing the guard to the mount with the supplied hardware.

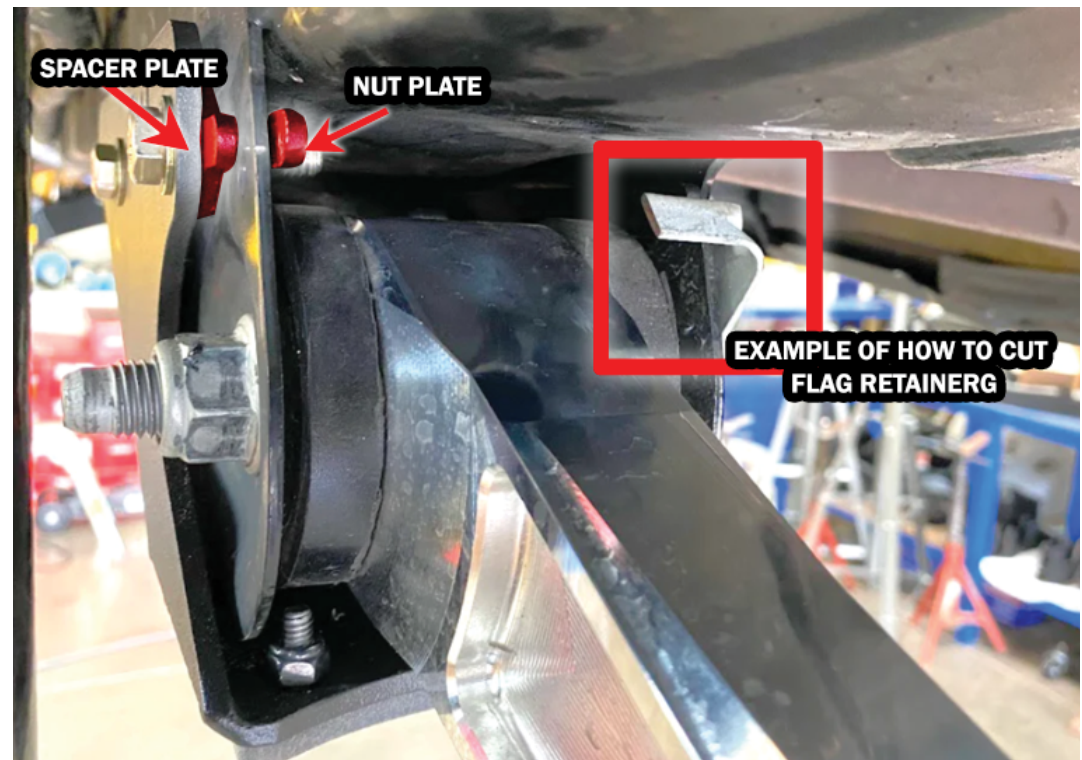



REAR LOWER ARM FRAME GUARD

INSTALL WITH HDPE SLIDE FOR **BRONCO & BRONCO RAPTOR**

PAGE 10

Step 3:

On the passenger side on the inside of the frame rail, there is a cover that covers the head of the bolt, this will need to be removed. This can be done with a small ratchet and a t25 torx bit (the lower profile the easier it is) The gas tank does not need to be removed.

Step 4

Once the guard has been removed, the same procedure as step 1 will need to be done. The tail on the retaining flag is too long for it to be completely removed without removing the gas tank.

We recommend pushing the bolt out as far as possible so it is touching the gas tank, then cut the flag off flush with the outside of the link mount.

DO NOT CUT THE BOLT.

Once the tail has been cut, the bolt can be rotated out of the way for clearance for the link guard.



REAR LOWER ARM FRAME GUARD

INSTALL WITH HDPE SLIDE FOR BRONCO & BRONCO RAPTOR

PAGE 11

Step 5

If equipped with a stock gas tank skid, remove the bolt directly in front of the link mount and loosen the bolt behind the link mount. Then loosen the other two bolts in front of the bolt that was removed.

Step 6

The link guard can now be installed. The guard will slide underneath the tab on the gas tank skid and reuse the factory bolt. Leave loose at this time. Then the supplied spacers and nut tabs can be installed, same as in step 2.

The nut tab and spacer are not required to be installed on the inside of the frame rail due to the clearance with the gas tank.

(It can be done and does add strength, but it isn't required)





REAR LOWER ARM FRAME GUARD

INSTALL WITH HDPE SLIDE FOR BRONCO & BRONCO RAPTOR

PAGE 12

Step 7

Once all hardware is started, tighten down all the hardware and retighten the gas tank skid bolts to factory specs.

Step 8

Enjoy your new lower rear link guards! Feel free to tag us in any photos or videos with this product installed next time you hit the trails or go rock crawling.

We will repost / share to our instagram & facebook page: @FoutzMotorsports #FoutzMotorsports

