

FIREFOX

14+

INSTRUCTION MANUAL

FIREFOX

6-AXIS GYRO 4 CHANNEL SERIES



Contents

1	Important Note Additional Safety Precautions And Warnings
2	Warning And The Guide Of Using Battery
3	Helicopter Parameters Packaging List
4	Introduction of transmitter function PARTS
5	Batteries Charging Method first flight Preparation caution
6	Installation method of remote controller battery Direction of operation
7	Flight Operation Steps
8-9	Flight Yaw correction method
10	Parts replacement instructions
11	Abnormal Problem Solving Method



6 axis gyro mode, Barometer setting,
flying ultra-stable, especially for beginners
flight



- Please read the manual to learn the function of the this product before operation.

Damage to the product and potential personal injury may occur if you make an operational error.

This is a RC helicopter, not a toy. You should not only have a prudent operation, but also to have an operational basis. All children using it should be under adult supervision.

The manual includes safety, operation and maintenance. In order to avoid causing damage or serious injury, please obey the instructions and warnings before you using this product.

Additional Safety Precautions And Warnings

FIREFOX

1. Recommended age of users: Not suitable for children under 14 years old.
2. Operate it in an open space, away from the traffic and people.
3. Obey the instructions and warnings, includes the use of optional equipment.
4. It has to stay away from chemicals. Small parts and electric equipment must be out of the reach of children.
5. Keep away from water because this product has no waterproof function.
6. Do not put any parts in the mouth, it will cause injury or death.
7. Don't operate the model if the transmitter's battery is in low voltage.
8. Don't view the beam of the light emitting diodes, it would effect the eyesight.
9. The motor and electric equipment will be heat after flight. Please do not touch them to avoid scald.
10. In order to avoid causing damage, please do not touch the high-speed.



Note: Using the original factory USB charger can ensure charging safety. Suggest you use the original factory USB charger part, other chargers may cause battery damage and property damage.

Warnings! The battery will fire, explode or leak if not strictly observing this item described below. :

1. Do not immerse the battery in water or seawater, and keep the battery in a cool dry environment during stands by period.
2. Keep all batteries out of the reach of little children. Consult a doctor immediately if a battery is swallowed.
3. Do not use or leave the battery near a heat source such as fire or heater.
4. Use the battery charger specifically for that purpose when recharging.
5. Do not reverse the positive (+) and negative (-) terminals.
6. Do not connect the battery to an electrical outlet.
7. Do not dispose the battery in fire or heat.
8. Do not short-circuit the battery by directly connecting the positive (+) and negative (-) terminals with metal objects such as wire.
9. Do not transport or store the battery together with metal objects such as necklaces, hairpins etc.
10. Do not strike or throw the battery against hard surface.
11. Do not directly solder the battery.
12. Do not unpack the battery with a nail or other sharp object.
13. Never disassembling the battery in any way.

Note: The battery can not be placed for a long time under full power and low power.

Otherwise, the battery will not be charged or the battery will be wrapped. For long-term storage, please charge the battery to 3.7V and store it in a dry and safe place.

Length	268 mm
Height	80 mm
Weight	52g
Propeller length	249 mm
Tail Rotor blade Diameter	37 mm
Battery Specification	300mAh
Flight time	About 15 min
Main Motor	8520
Tail Motor	0615
Charge time	About 75 min

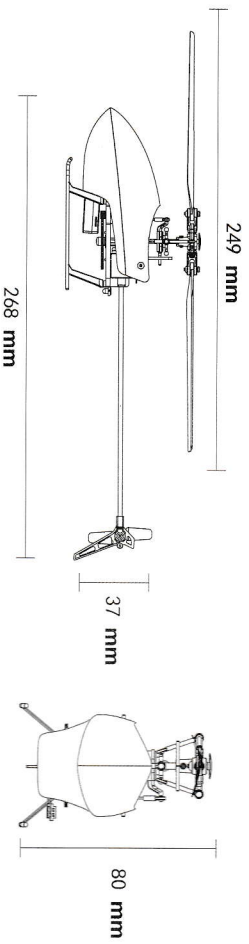

Packaging List

FIREFOX

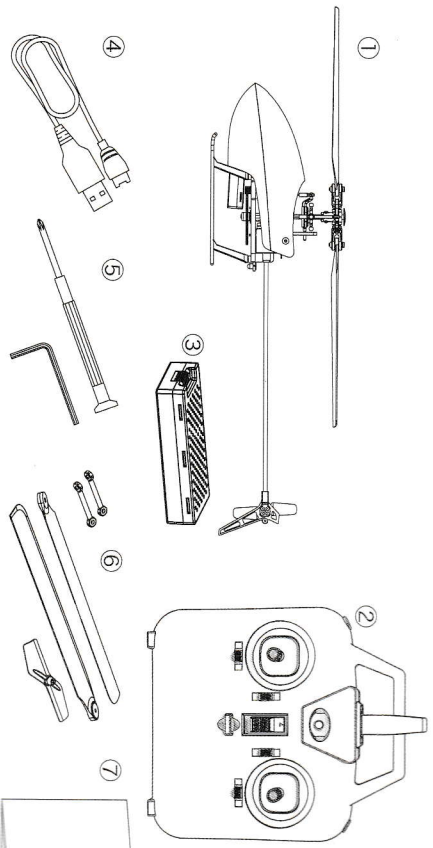

- ① Helicopter
- ② Remote Control
- ③ Lipo battery
- ④ USB charger
- ⑤ Phillips screwdriver+hex wrench
- ⑥ Upper connecting rod / Propeller / tail rotor
- ⑦ Instruction manual

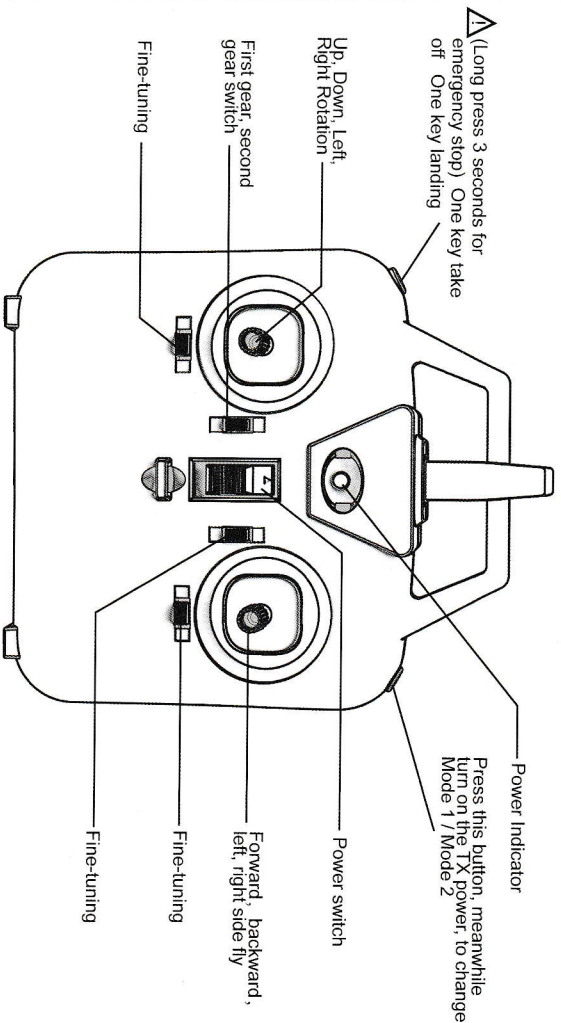

▲ (Long press 3 seconds for emergency stop) One key take off One key landing

Press this button, meanwhile turn on the TX power, to change Mode 1 / Mode 2

PARTS

FIREFOX

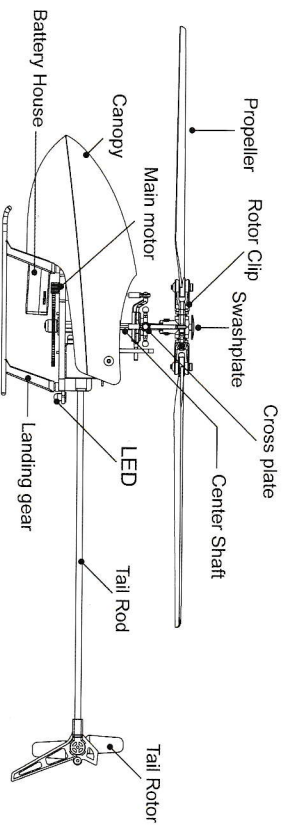

Charging method 1
Charging battery by the USB port on a computer.

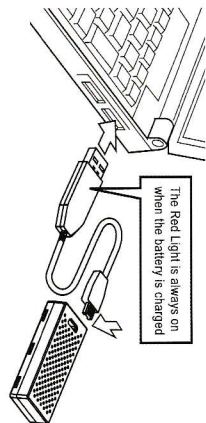

- Description:
1. Connect the USB charger with USB port.
 2. Connect the battery with USB charger: red light means it is charging, red light out means charging complete.

Charging method 2: Charging battery by power supply adapter.

1. Connect the USB charger with power supply adapter.
2. Connect the battery with USB charger: red light means it is charging, red light out means charging complete.

Charging method 3: Charging battery by power bank

1. Connect the USB charger with power bank .
2. Connect the battery with USB charger: red light means it is charging, red light out means charging complete.

FIRST Flight Preparation CAUTION

1. ensure sufficient power supply of the transmitter and helicopter.
 2. Keep a flight in a suitable space which away from the traffic, people, electricity pylons and pool.
 3. Do not lock the main rotor screws too tightly to keep folding smoothly. If the main rotor screws are too tight, the helicopter will shake when flying.
 4. Under emergency situation, you can press "sharp stop" button for 3" to land the helicopter without rotating.
- (Note: this action may cause helicopter crash.)

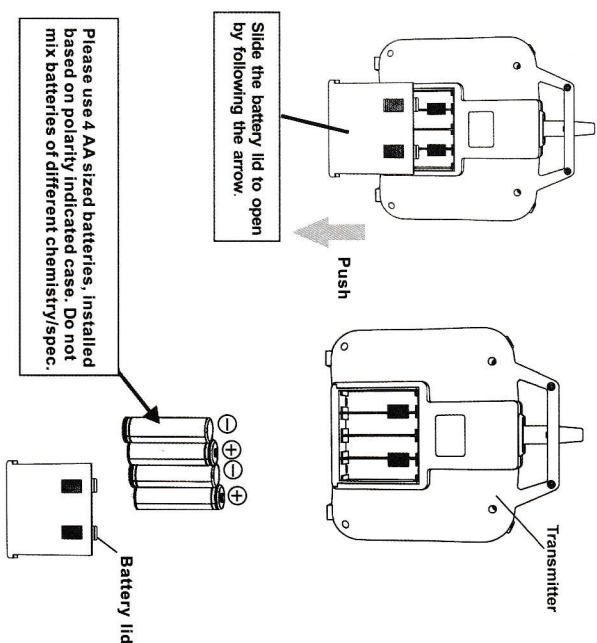
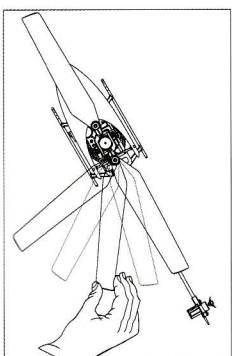

Direction of operation

If you are unfamiliar with the control of the FIREFOX, take time to familiarize it before your first flight.

Throttle

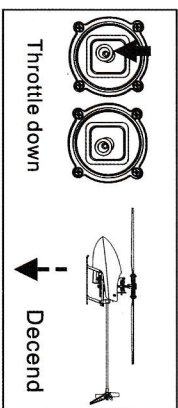
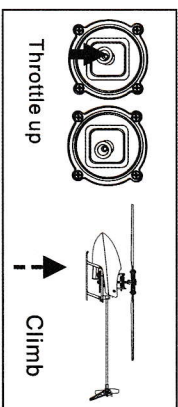

Rudder

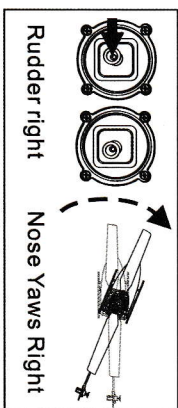
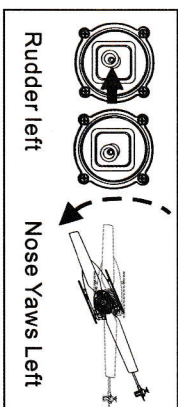

Elevator

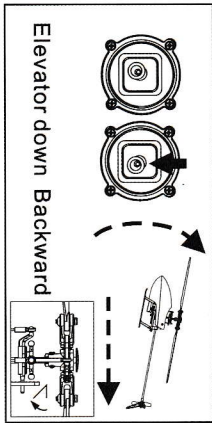
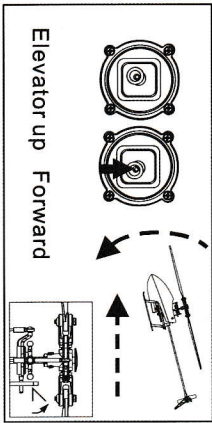

Aileron

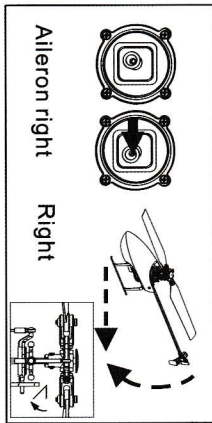
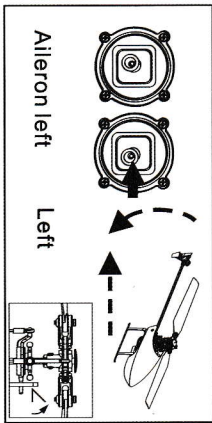

1. Turn on the transmitter and let helicopter stay near to transmitter.

2. Connect the battery with helicopter.

3. The lights of the helicopter and the remote control flash at the same time. Then push the throttle stick from top to bottom quickly. The remote control makes a 'DI' sound, and the indicator lights of the helicopter and remote control are always on, which means binding successful.

4. Pull the two joysticks to outer eight angles to start the helicopter. (You can also press the one-key takeoff button to take off the helicopter directly.)

5. Keep the helicopter head forward, and keep safe distance with the helicopter.

6. When manually operating the aircraft to land, please keep the throttle stick at the bottom for 2-3 seconds, and then release it after the propeller has completely stopped rotating.

(This operation is not required when using the one-key landing function)

△Note: 1. In order to avoid hitting, do not look at the helicopter at hip level when it fly.

2. In order to avoid distractions, please confirm without other transmitters at work around.

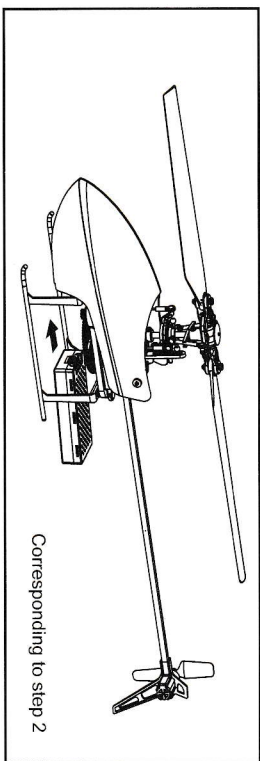

Corresponding to step 2

Note: Beginner should pay attention to the direction of flight. Keep the head forward to avoid causing injury.

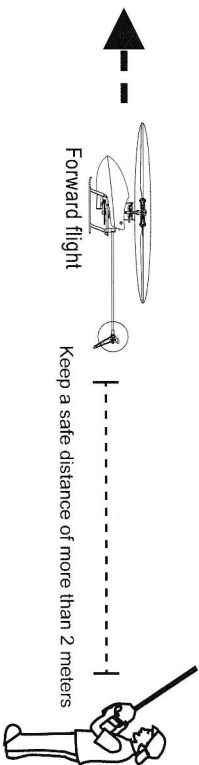

Flight Yaw correction method

FIREFOX

Press the trimming button when helicopter has yaw problems.

The helicopter has set up hovering. If you are dissatisfied with hovering or the helicopter have a yaw, please follow these steps to adjust.

Take off with the throttle joystick. According the direction of yaw, press the fine-tuning button in the opposite direction until the plane hovering.

Forward/ backward Yaw			Fine-tune according to the direction of the arrow
Left/right Yaw			Fine-tune according to the direction of the arrow
Side fly Yaw			Fine-tune according to the direction of the arrow

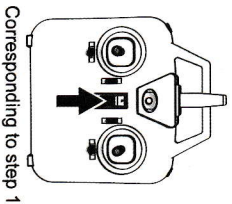

Corresponding to step 1

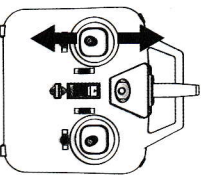

Corresponding to step 3

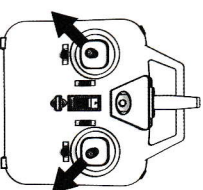

Corresponding to step 4

Trimming Notes

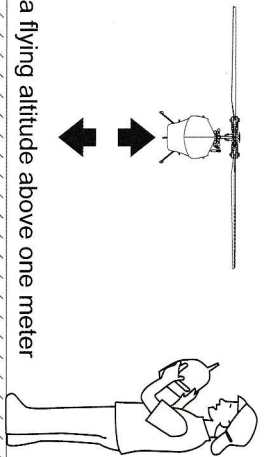

Warning
Maintain a flying altitude above one meter

Remove the propeller with a hex wrench. Be careful not to be too tight when installing the new propeller.

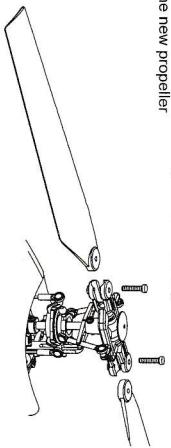

When replacing the tail rod, pull the plug backwards forcefully, pay attention to the direction when installing, and align the power cord with the hole.

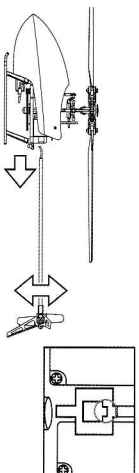

Unplug the plug, then twist the motor left and right to pull out

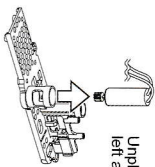

Pay attention to the connecting rod direction when disassembling and replacing the servo, as shown:

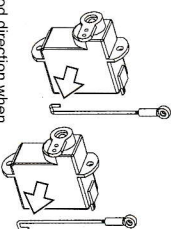

Pull out the landing gear downwards, and press the corresponding holes when installing.

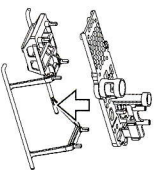

When replacing the receiver, remove the double-sided tape together, align the new receiver with the edge of the rack and stick it tightly without skewing, and then connect the servo and the motor in the order of the plugs.

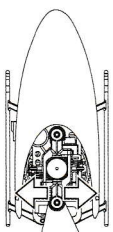

Introduction of the corresponding socket of receiver

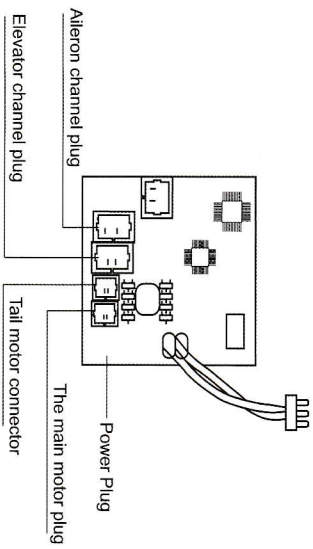

Gyro calibration method

1. When flying yaw, first land and calibrate the gyroscope.
2. When calibrating the gyroscope, the aircraft must be placed on a level ground.
3. The indicator light will flash quickly during the calibration process, the indicator light stops flashing to take off.

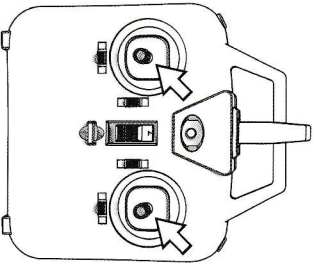

Pull out the big gear straight down, pay attention to the direction when installing the new gear, and the axis plane should be aligned with the plane of the inner hole of the gear.

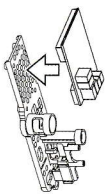
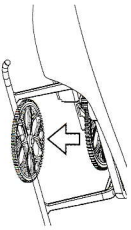

When removing and replacing the tail rotor, please pay attention to the direction, align the motor shaft and press it slowly to ensure smooth rotation.

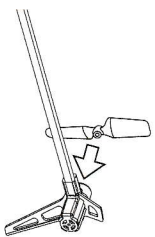

Problem	Possible Cause	Solution
1 Connect the battery with helicopter, then the signal light keeps flashing and without response when operate.	The helicopter without bind with the transmitter.	Bind the transmitter again tightly
2 The helicopter without any response when you connect the battery.	Check the power supply of helicopter and transmitter; Check the battery's voltage of the helicopter and transmitter; Batteries had a poor connecting.	Check the installation site of Transmitter's batteries; Use full voltage batteries; Install the batteries again; Confirm the batteries have a good connecting.
3 Push the throttle but the motor not at work, the receiver's signal light keep flashing	Helicopter's battery has a low voltage; The lipo battery has a poor connecting.	Charge the battery or change a full charge battery; Connect the battery with receiver again.
4 Turn on the helicopter after bind, the main blade can rotate but the helicopter can not take off	Helicopter has a low voltage; The main shaft and the gear may loose.	Charge the battery or change a full charge battery; Press the main shaft and gear tightly
5 The helicopter is violently shaking	Main rotor deformed cross shaft bent tail rotor bent Blade clamp screws are too tight to cause the main blade can not rotate	Change the main blade; Change the cross shaft; Change tail rotor; Loose the blade clamp screw.
6 Helicopter spinning to left after take off.	Tail motor has a poor power; The blades loose; Tail motor was broken.	Check the connection of tail blade and motor shaft; if loose, change tail blade or tail motor.
7 The helicopter has a little yaw.	made a operational error of the trimming button	1.According to its yaw direction, push the trimming button in the opposite direction; 2.Reset the hovering point.
8 The helicopter has a serious yaw.		Check the servo if work properly; Check the swash plate; Check the rod sticks if loosing.