



BAe HAWK T.1A

FREEWING 1/8 SCALE 70mm EDF JET

USER MANUAL

WINGSPAN: 1020MM (40.16")

LENGTH: 1221MM (48.1")

EMPTY WEIGHT: 1450G (W/O BATTERY)

EN	1~9
中	10~18



www.sz-freewing.com

MADE IN CHINA

Perhaps the most versatile British advanced trainer jet in the world, the BAe Hawk has been in service for over 40 years. Operated at its peak by 18 countries in various trainer and light combat roles, the Hawk T1 variant was also popularized by the Red Arrows display team, whose expert piloting demonstrations have amazed audiences worldwide for generations.

Freewing and Motion RC are proud to present this well-loved aircraft as a 70mm EDF powered electric flying model. The Freewing 70mm Hawk T1 features a powerful 12 bladed EDF power system for satisfying speed, vertical performance, and realistic sound.

With a 6s 2600mAh-4500mAh LiPo battery, the 6s power system can achieve a top speed of approximately 160kph / 100mph. Retractable landing gear, flaps, and a wide gear stance make the aircraft well suited for intermediate jet pilots and short grass runways. An optional suspension strut set is available if more shock absorption is desired. A large battery bay provides easy access to your battery, receiver, and an optional gyro stabilizer.

To enhance visibility, the Freewing 70mm Hawk T1 also features the signature bright white nose light of the real aircraft, and sports bright red and green wingtip lights as well. This is the only Freewing 70mm Class aircraft to include pre-installed lighting!

Celebrating the Red Arrows Demonstration Team's approach to 40 years with their BAE Hawks, the Freewing Hawk T1 is finished in one of the iconic Red Arrows liveries. It is our hope that as you enjoy this model aircraft, you will spread the love of flight and of this historic aircraft's contributions to aviation history.

⚠ NOTE: This is not a toy. Not for children under 14 years. Young people under the age of 14 should only be permitted to operate this model under the instruction and supervision of an adult. Please keep these instructions for further reference after completing model assembly.

Note:

1. This is not a toy! Operators should have some basic experience. Beginners should operate only under the guidance of a professional instructor.
2. Before beginning assembly, please read through the instructions and carefully follow them throughout the build.
3. Freewing and it's vendors will not be held responsible for any losses due to improper assembly and operation.
4. Model airplane operators must be at least 14 years of age.
5. This airplane is made of EPO foam material, covered with surface spray paint. Don't use chemicals to clean as it may cause damage.
6. You should avoid flying in areas such as public places, areas with high voltage power lines, nearby highways, airports or in other areas where laws and regulations clearly prohibit flight.
7. Do not fly in bad weather conditions, including thunderstorms, snow, etc...
8. Lipo batteries should be properly stored in a fire proof container and be kept at a minimum of 2M distance away from flammable or explosive materials.
9. Damaged or scrap batteries must be properly discharged before disposal or recycling to avoid spontaneous combustion and fire.
10. At the Flying Field, properly dispose of any waste you have created, don't leave or burn your waste.. Ensure that your throttle is in the low position and that your radio is turned on before connecting the Lipo battery.
11. Ensure that the throttle is in the lowest position and transmitter is turned on before connecting a Lipo Battery to the ESC of the aircraft.
12. Do not try to catch the airplane while in flight or during landing. Wait for the airplane to come to a complete stop before handling.

Index

Introduction.....	1	Install Scale Accessories	4
Basic Product Information	2	Pushrod instructions	5
Package List	2	Control Board Instructions	5
PNP Installation Instructions		Battery Size.....	6
Traction steel wire use instruction	3	Center of Gravity.....	6
Install Horizontal Stabilizer.....	3	Servo Direction.....	7
Install Vertical Stabilizer.....	3	Motor Specification.....	7
Install Main Wing.....	4	Control Direction Test.....	8
		Dual Rates.....	9

Product basic information

EN

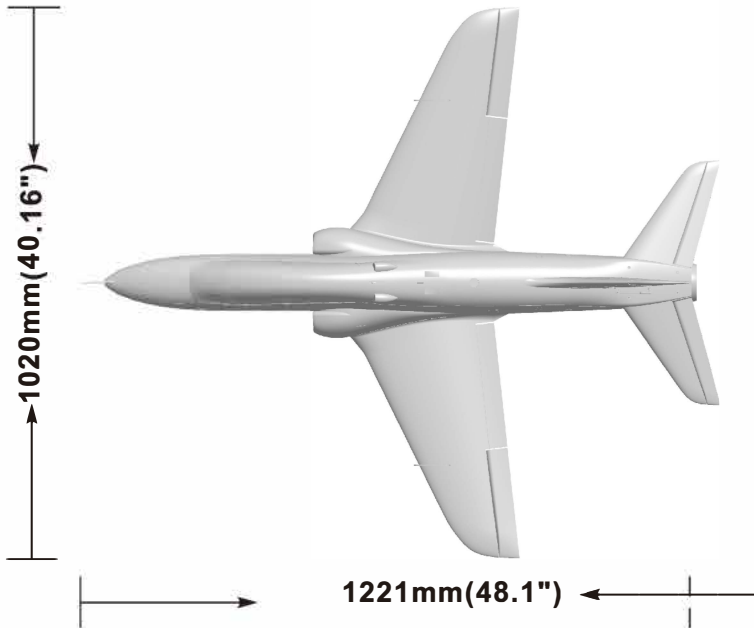

Standard version

Wing loading: 97.5g/dm²
 Motor: 3048-2300KV
 brushless outrunner motor Ducted fan: 70mm 12-blade fan
 ESC: 80A brushless
 Servo: 9g digital metal gear servo(8pcs)
 Flight speed : 160KPH/100MPH Empty
 Weight: 1450g(without battery) Thrust: 2300g

Other features

Material : EPO
 Ailerons: Yes
 Split Flaps: Yes
 Elevator: Yes
 Rudder: Yes
 Landing gear: Retractable, Suspension
 Scale LED lights
 Scale Pilot figure
 Battery: 6S 2600-4500mAh (1)

⚠ Note: The parameters stated here are derived from test results using our accessories.

If you use other accessories, the test results will differ. We cannot provide technical support if you have a problem when using other accessories.

Package list



Different types of kits will come with certain specific parts. Refer to the list of parts for your type of kit in the chart below.

No.	Name	PNP	ARF Plus	Airframe	No.	Name	PNP	ARF Plus	Airframe
1	Fuselage	Pre-installed all electronic parts	Pre-installed servo	No electronic equipment	7	Control board	✓	✓	✓
2	Main wings	Pre-installed all electronic parts	Pre-installed servo	No electronic equipment	8	Traction steel wire	✓	✓	✓
3	Horizontal tail	Pre-installed all electronic parts	Pre-installed servo	No electronic equipment	9	Linkage Set	✓	✓	✓
4	Vertical tail	Pre-installed all electronic parts	Pre-installed servo	No electronic equipment	10	Manual	✓	✓	✓
5	Drop tank	✓	✓	✓	11	Glue & Non-slip mat	✓	✓	✓
6	Scale Accessories	✓	✓	✓	12	Screw	✓	✓	✓

Traction steel wire

Our tests show that excessively long servo extension lines increase the rise of poor connections that can lead to servo brown outs or failure, causing accidents during flight. Instead, this kit contains a steel wire that can be used to pull the main wing/elevator and rudder servo wires through the airplane to the battery compartment, eliminating the need for extension wires.

Horizontal Stabilizer Assembly

As shown in the photo below:

1. Feed the elevator servo cables into the wire channel in the rear portion of the fuselage.
2. Use the steel wire to pull the elevator servo cable to the battery compartment.
3. Place the elevator on the rear fuselage and secure with 4 screws (PA2.6x10).

- A-Elevator servo cable
- B-Elevator wire channel
- C-Elevator
- D-Screw (PA2.6x10 4pcs)

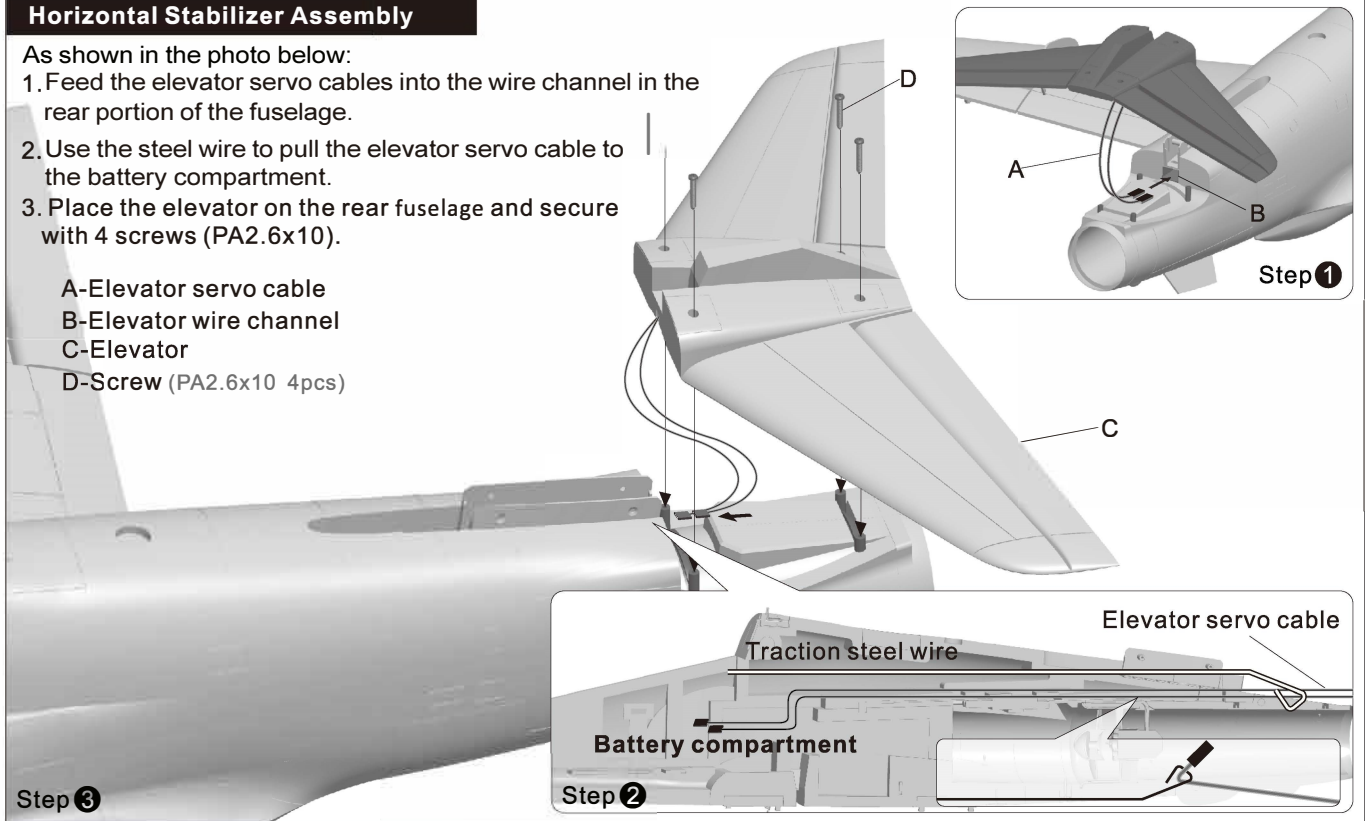

Vertical Stabilizer Assembly

As shown in the photo below:

1. Insert the rudder servo cable through the plastic mount.
2. Use traction wire to pull the rudder servo cable to the battery compartment.
3. Place the rudder on the rear fuselage and secure with 4 screws (KA2.6x8).

- A- Rudder servo cable
- B- Plastic mount
- C- Rudder
- D- Screws (KA2.6x8 4pcs)

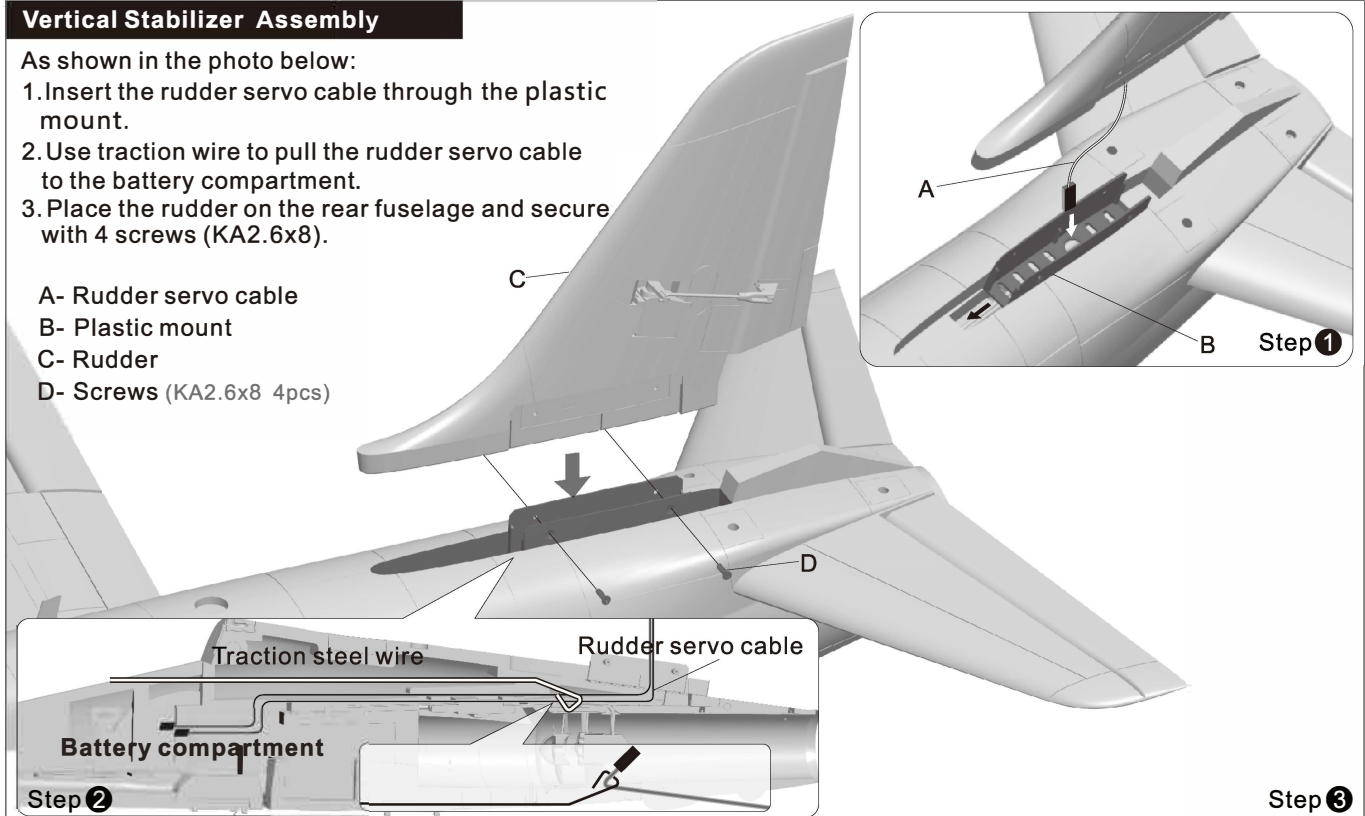

Main Wing Installation

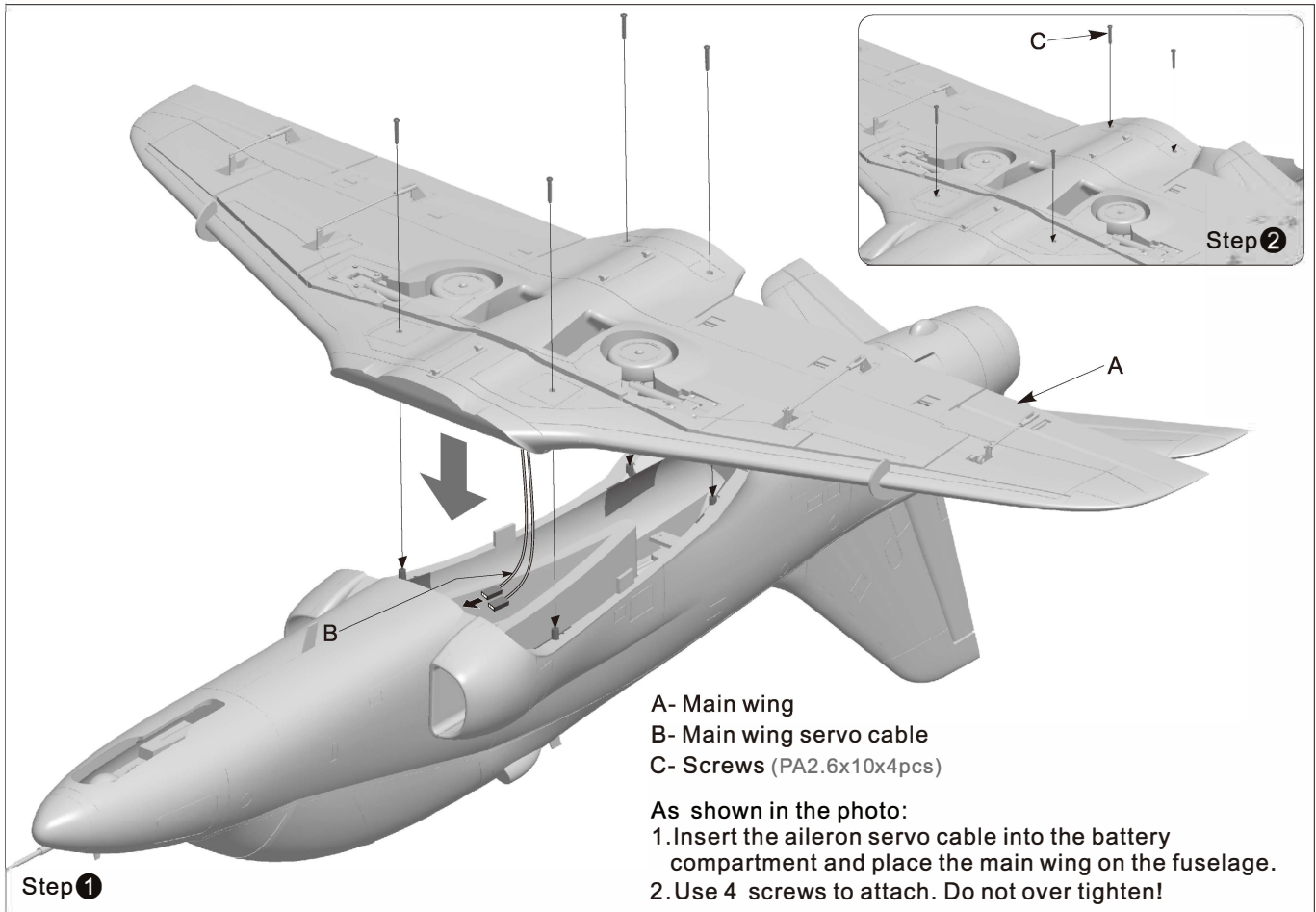

Scale Accessories Installation

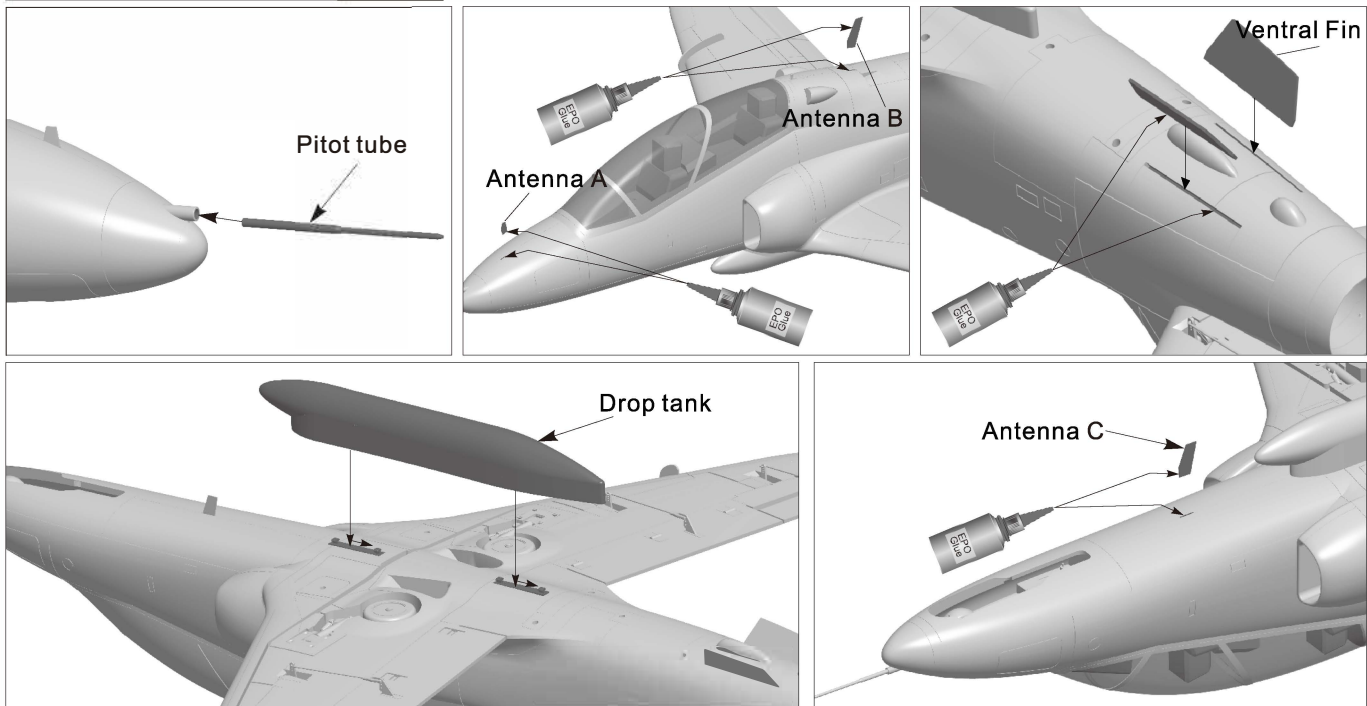

Note:
 After completing the above steps, insert each servo cable into its corresponding location on the labeled control board.
 (See the Control Board Instructions section of the manual for more information)

Pushrod instructions

Flap pushrod size

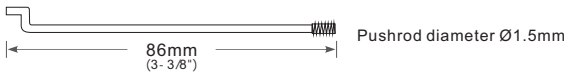

Flap pushrod mounting hole



Aileron pushrod size

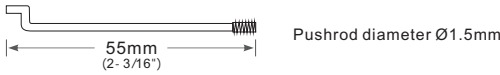

Aileron pushrod mounting hole



Elevator pushrod size

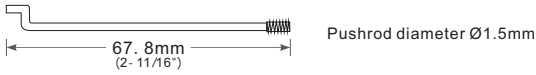

Elevator pushrod mounting hole



Rudder pushrod size

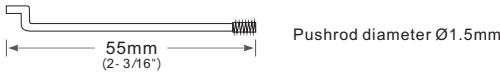

Rudder pushrod mounting hole



Control Board Instructions

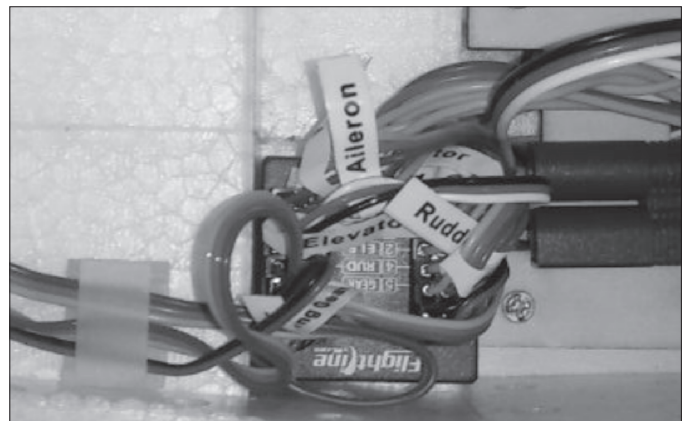
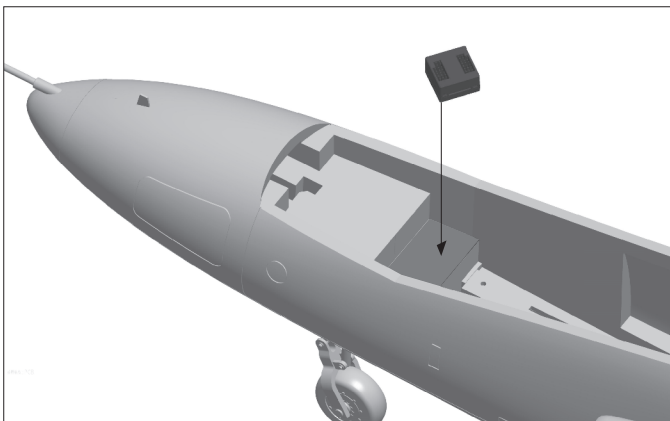
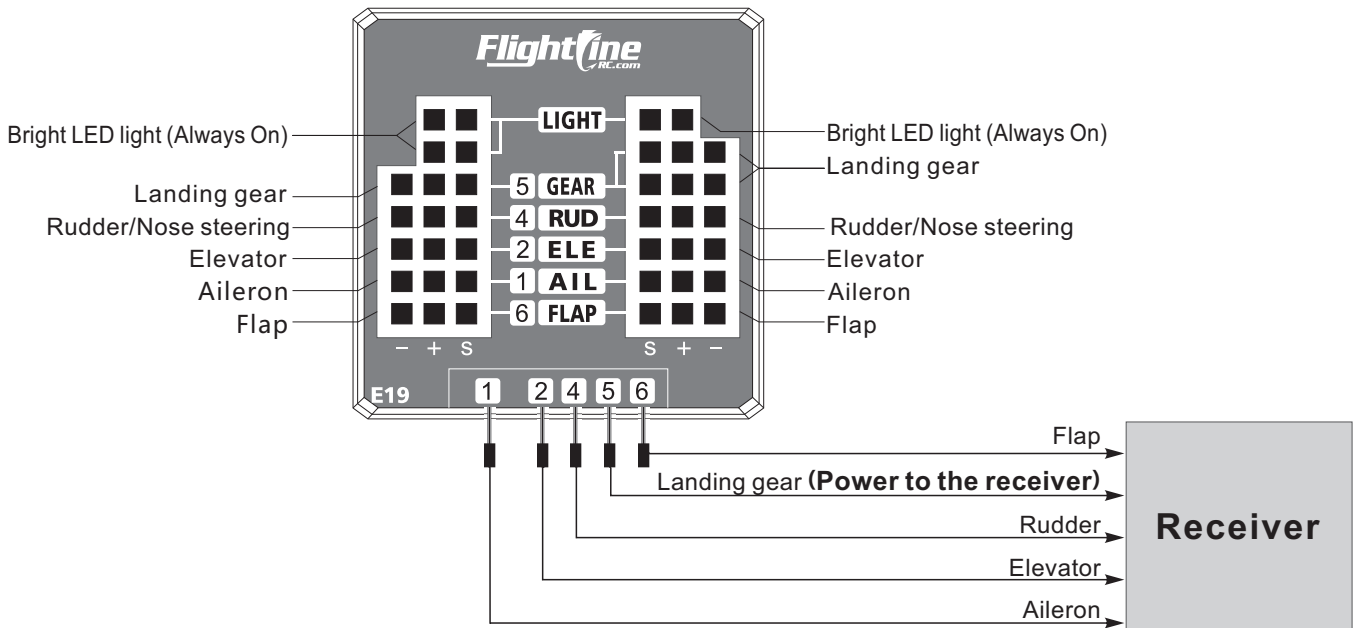

Insert each servo cable into its corresponding slot on the control board. Test and verify correct function of all control surfaces. After connecting all the servo cables, attach the control board in the location as shown above.

Battery Size

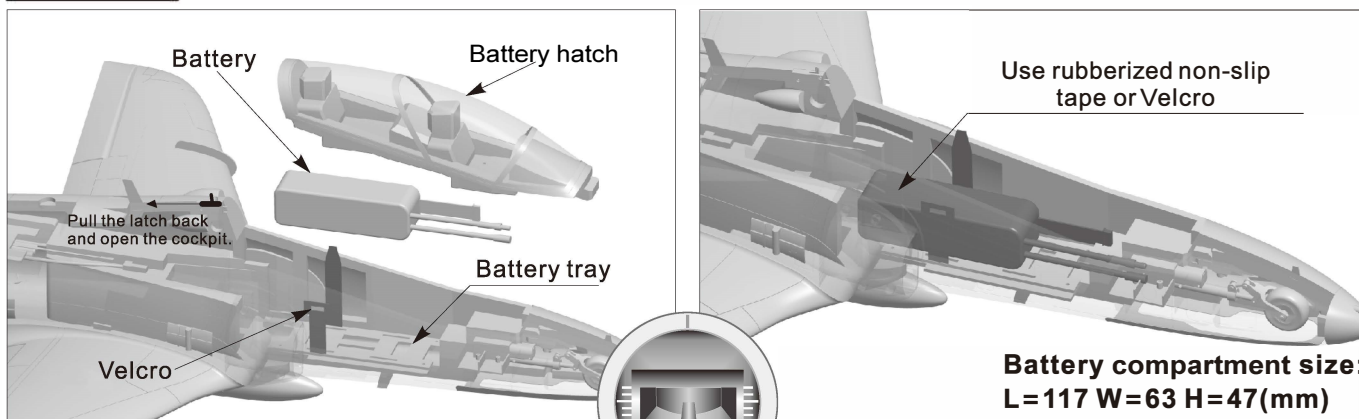

Before connecting the battery to the ESC, switch on the transmitter power and make sure the throttle stick is in the lowest position. Engage the kill switch if one is assigned. Bind your receiver to your transmitter according to your transmitter's instruction manual.

We recommend the following LiPo battery:
6S 22.2V 2600mAh ~ 6S 22.2V 4500mAh(1pc)
Discharge rate of C ≥ 30C

Center of Gravity

Correct Center of Gravity ("CG") is critical for enabling safe aircraft control. Please refer to the following CG diagram to adjust your aircraft's Center of Gravity. Once familiar with the aircraft, you can adjust the CG to suit your individual taste.

- You can move the battery forward or backward to adjust the Center of Gravity.
- If you cannot obtain the recommended CG by moving the battery to a suitable location, you can also install a counterweight to achieve the correct CG. However, with the recommended battery size, a counterweight is not required. We recommend flying without unnecessary counterweight.

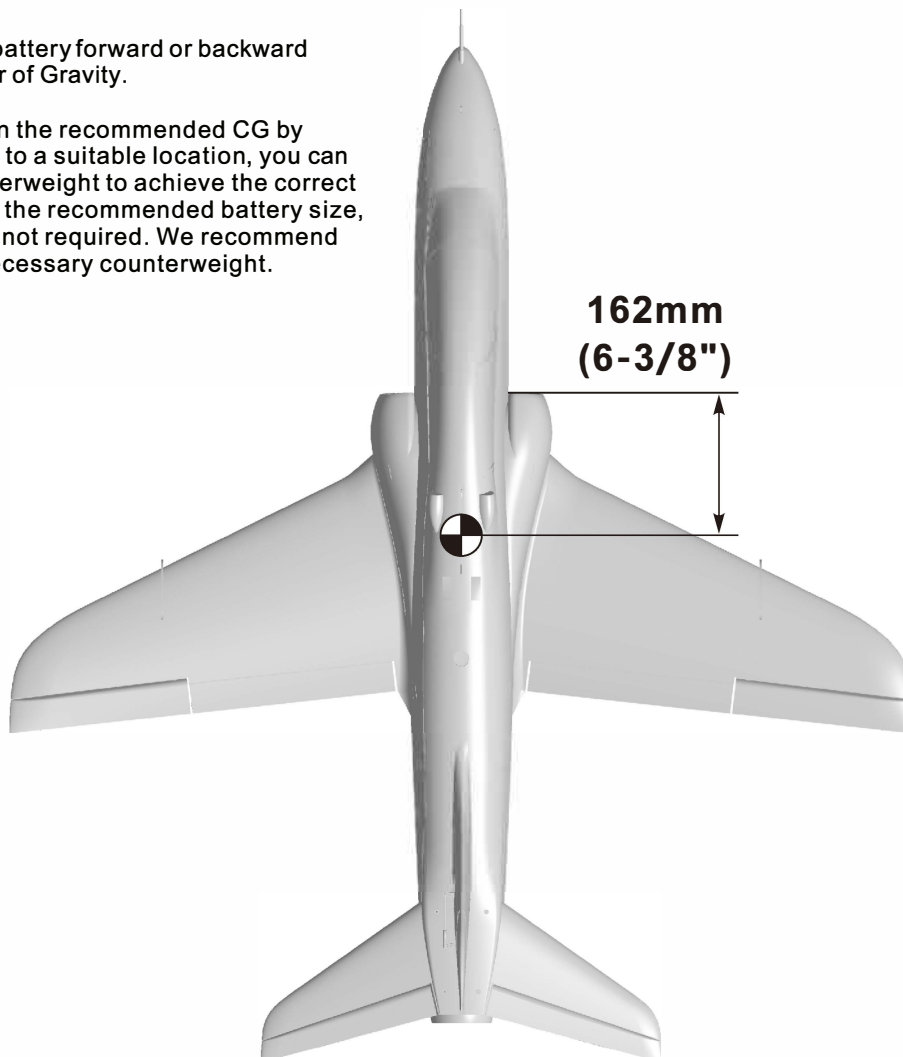

Servo Direction

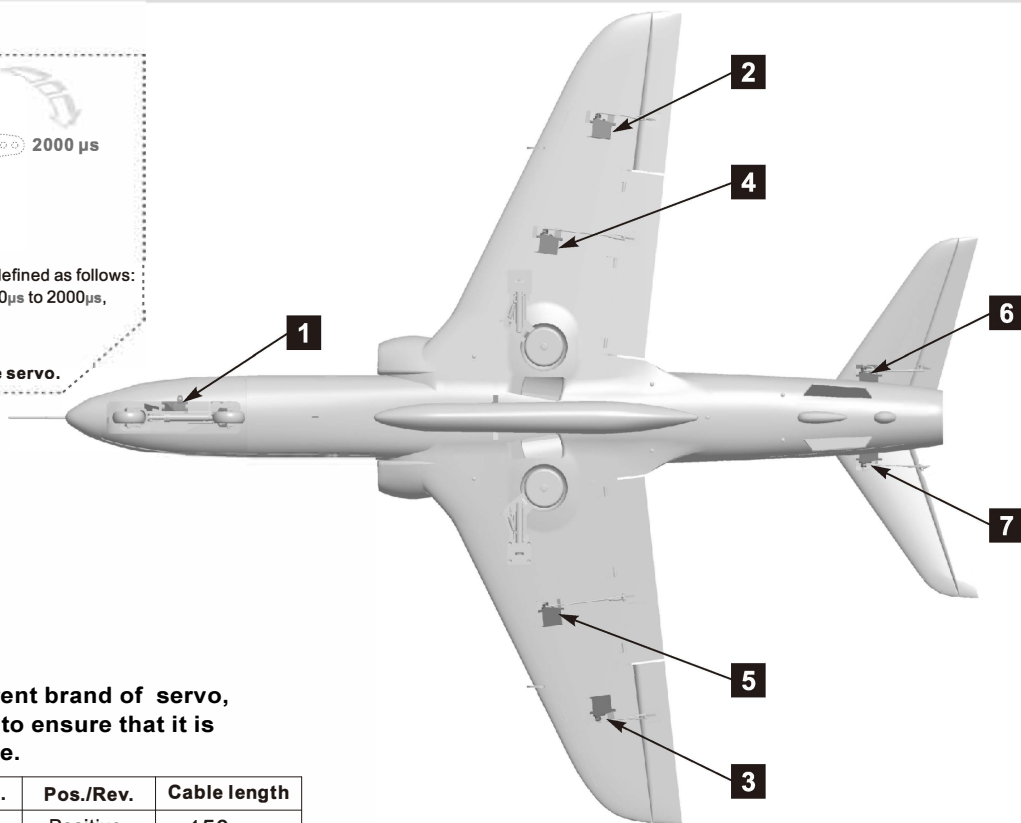
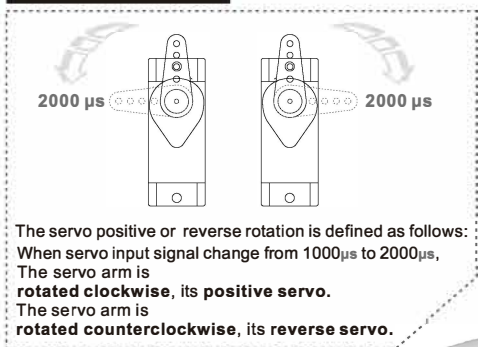

If you decide to use a different brand of servo, check with the chart below to ensure that it is compatible with the airplane.

Position	Servo regulation	No.	Pos./Rev.	Cable length
Nose gear steering servo	9g Digital-MG	1	Positive	150mm
Aileron(L)	9g Digital-MG	2	Positive	800mm
Aileron(R)	9g Digital-MG	3	Positive	800mm
Flap(L)	9g Digital-MG	4	Positive	750mm
Flap(R)	9g Digital-MG	5	Positive	750mm
Elevator(L)	9g Digital-MG	6	Positive	900mm
Elevator(R)	9g Digital-MG	7	Reverse	900mm
Rudder	9g Digital-MG	8	Positive	850mm

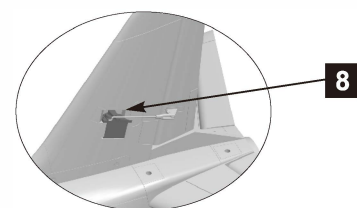

Motor Specifications

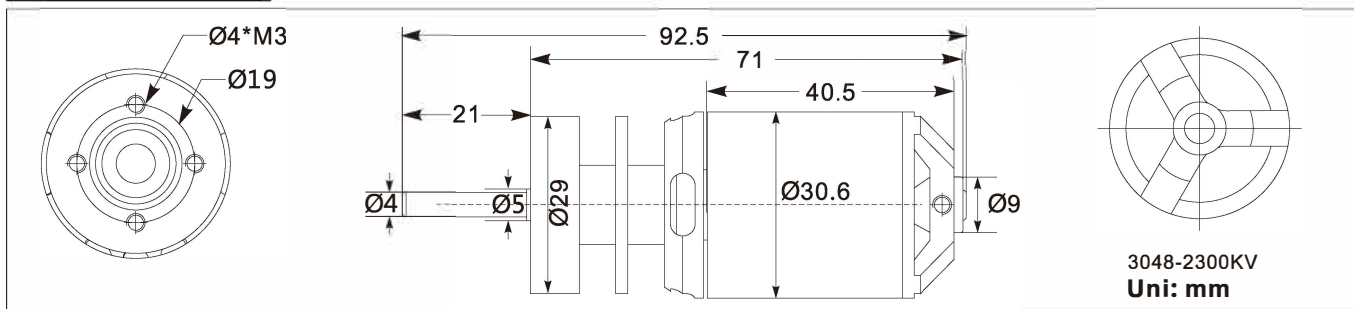

Item No.	EDF Fans	Use voltage (V)	Current(A)	Max power (W)	Thrust(kg)	Efficiency (g/w)	Motor Specifications (KV)	Rotating speed (rpm)	Weight (g)
E7217	70mm 12-blade EDF	22.2(6S)	65-72	1510	2.3-2.5	1.6	3048-2300	51000	150

Directional Control Test

After the build is complete, power up the radio, ensure the throttle is in the lowest position, engage the kill switch if one is assigned and connect a fully charged battery to the ESC. Use the radio to ensure correct control direction.

Aileron

Stick Left



Stick Right



Elevator

Stick Back

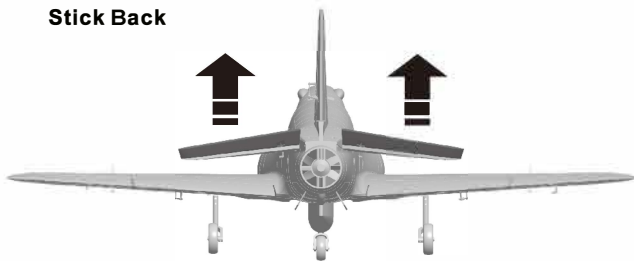

Stick Forward

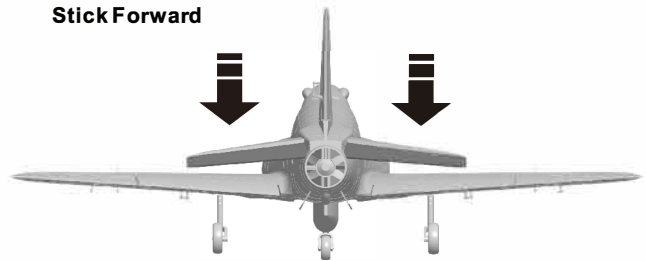

Rudder

Stick Left

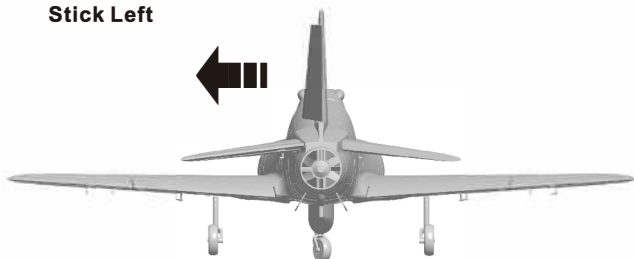

Stick Right

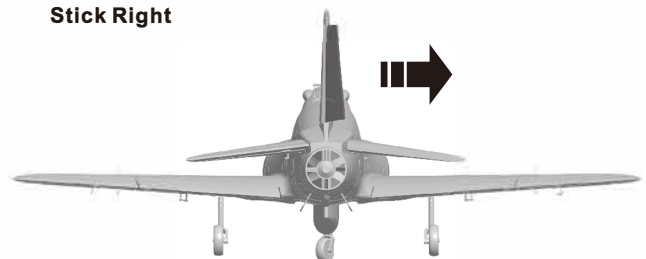

Flaps

Flaps down

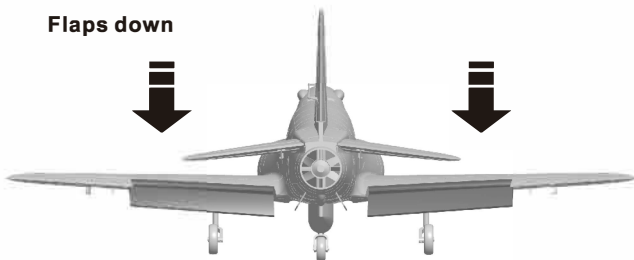

Dual Rates

According to our test results, the following rates proved to be a good starting point. Low rates are good for initial flights or less experienced pilots. High Rates will be more sensitive to control inputs. Program your preferred Exponential % and the following rates. After initial flights, adjust the rates to suit your own style.

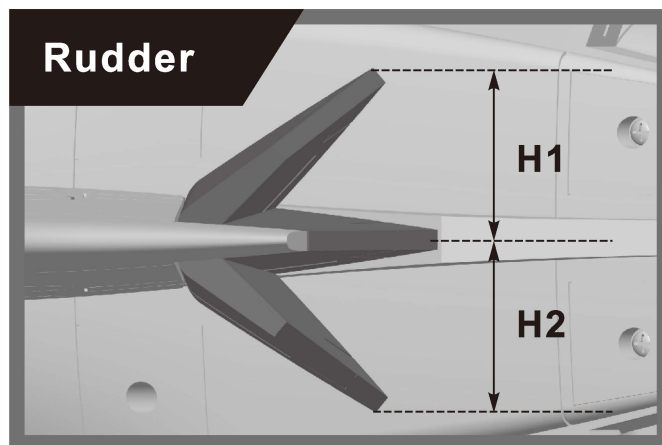
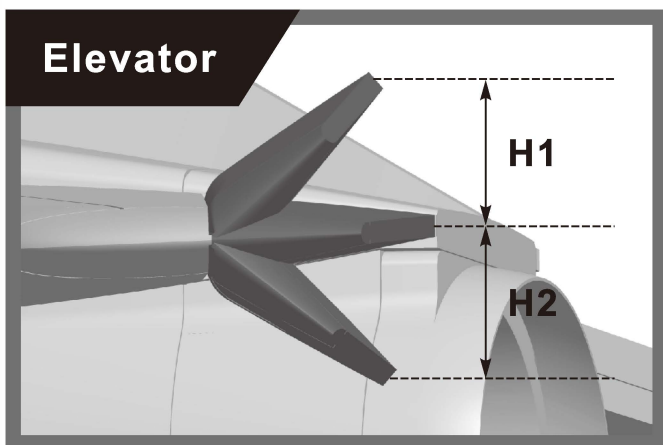
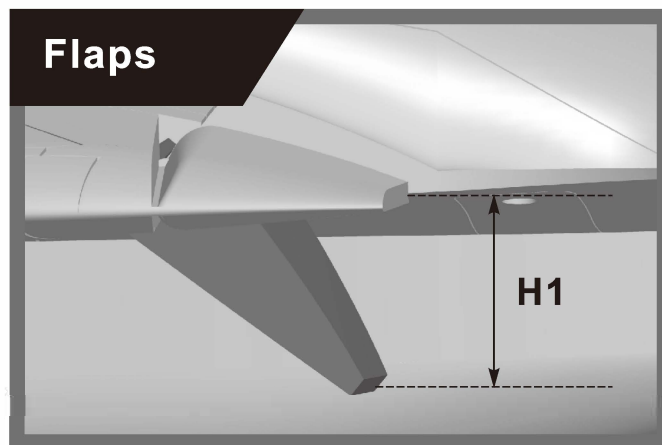
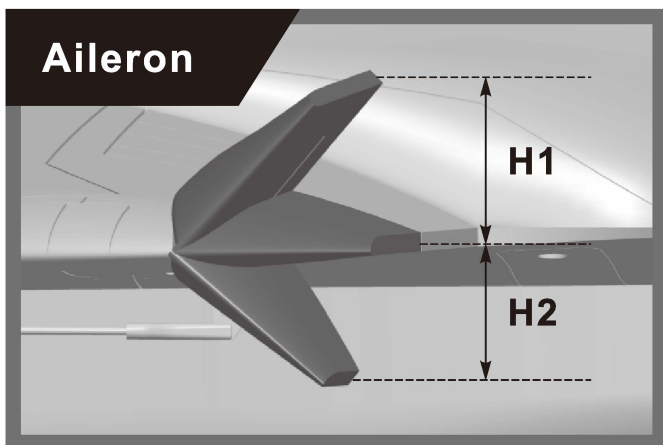

	Aileron(measured closest to the fuselage)	Elevator(measured closest to the fuselage)	Rudder(Measured from the bottom)	Flaps
Low Rate	H1/H2 18mm/18mm D/R Rate : 70%	H1/H2 22mm/22mm D/R Rate : 80%	H1/H2 22mm/22mm D/R Rate : 80%	H1 14mm
High Rate	H1/H2 21mm/21mm D/R Rate : 100%	H1/H2 25mm/25mm D/R Rate : 100%	H1/H2 26mm/26mm D/R Rate : 100%	H1 23mm



Dongguan Freewing Electronic Technology Ltd
HK Freewing Model International Limited

Add.: Fei Yi Building, face to Labor Bureau, Fumin Middle Road, Dalang Town,
Dongguan City, Guangdong Province, China
Web: <http://www.sz-freewing.com>
Email: freewing@sz-freewing.com
Tel: 86-769-82669669 Fax: 86-769-82033233

东莞市飞翼电子科技有限公司
香港飞翼模型国际有限公司

地址: 广东省东莞市大朗镇富民中路402-408号飞翼楼四楼
Web: <http://www.sz-freewing.com>
Email: freewing@sz-freewing.com
Tel: 86-769-82669669 Fax: 86-769-82033233

