

# ***F-14A Tomcat*** ***User Manual***

**Wingspan:1250mm**

**Length:1217mm**

**Empty Weight:2555G[w/o Battery]**



EN 1~12

中 13~24

1	Introduction
2	Product basic information
2	Package list
3	PNP Assembly instructions
3	Install horizontal stabilizer
3	Install the fins
3	Install vertical stabilizer
4	Install main wing
6	Install missiles
6	Install nose cone and decorated parts
7	Battery instructions
7	Important additional notes
8	Center of gravity
9	Control Board Introduction
10	Control direction test
11	Dual rates
12	Servo direction
12	Motor specification

13	前言
14	产品规格参数
14	包装列表
15	PNP组装步骤介绍
15	平尾组装
15	腹鳍组装
15	垂尾组装
16	主翼组装
18	导弹组装
18	仿真小配件、机头罩安装
19	电池介绍
19	舵面控制钢丝尺寸及安装孔位
20	重心示意图
21	集线控制板介绍
22	模型舵面测试
23	舵量范围
24	舵机介绍
24	电机介绍

Thank you for purchasing our Freewing model dual 64mm EDF fighter, the F-14 "TomCat"! it is a supersonic, dual engine, dual seat, dual tail and variable sweep wing carrier fighter, designed by Grumman for the US Navy. It was first deployed in 1974 to replace the F-4 II "Ghost" and gradually became the main carrier fighter until its complete retirement in 2006. Since its service, the F-14 "Tomcat" has been loved by many military fans for its beautiful appearance and unique variable sweep wing design with science fiction colors.

This Freewing 1/15 scale F-14A "TomCat" dual 64mm EDF model jet uses EPO material and overall shape is very scale. The color scheme is based on the 1987 VF-84 Jolly Rogers Pirate Flag Squadron as a prototype. The exquisite water stickers, high-level oil spraying technology, surface markings and rich details of the fuselage push the product's simulation to a new level. Moreover, this F-14A model aircraft also has three different types, totaling six weapon models (AIM-7, AM-9, and AIM 54C), and all weapon models are fixed and easy to disassemble using slide rail installation. In addition, it pre-installed with 6 LED simulated navigation lights, distributed on the wing tips and edge wings.

In terms of structure, it used the screws to fix the main wing, vertical tail and horizontal tail. After flight, it can be disassembled and stored in the package box again. The aluminum wing box has high strength, which is sufficient to resist the huge load brought by the main wing during flight, prevent bending deformation, and effectively ensure flight quality. Metal shock absorber retract landing gear is stable and reliable with good shock absorption performance. For the front landing gear, increased the additional scale decorated plastic part and complete cabin doors. When the rear landing gear is retracted, the wheels are positioned with a 90 degree deflection. The mount of landing gear are designed with secondary reinforcement and decentralized unloading, greatly improving the load capacity during landing.

This Freewing 64mm Series dual F-14A "TomCat" dual 64mm EDF model jet, the variable sweep wing is controlled by two pcs new improved 8KG/23g programmable servo<sup>①</sup>, with adjustable rotational speed and constant output torque. Moreover, through the radio setting, multiple angle wing changing settings can be achieved, making it more flexible to use and effectively improving the flight quality and controllability after wing changing. The new F-14 control board adds safety based restrictions to the movement of the flaps (When the flaps are deployed, the sweep wing cannot be retracted; when the sweep wing is retracted, the flaps cannot be deployed), effectively avoids accidents caused by retracting the flaps when using the flaps.

Two sets Freewing 64mm EDF in-runner 6S power system (2949-2500KV in-runner motor, static thrust is 1950g/set) provide strong thrust, use 60A ESC with thrust reverse function and equipped with a 6S 5000mAh 65C battery, it can achieve a cruising speed of 173KPH/185KPH (wing retraction).<sup>②</sup> At the same time, it has a 3-minute flight time while continuously flying at full throttle. The F-14A "TomCat" model jet is suitable for model pilots with some experience in electric model aircraft, with a minimum takeoff distance of about 35 meters. During the flight, the power response is moderate and the actions are executed accurately.

Control board pre-set the Flight Guard I gyro program<sup>③</sup>, ensures that the aircraft has good flight quality in both deployed wing and retracted wing positions. Of course, as a scale aircraft, its layout determines some flight situations that require our attention during flight: 1. Avoid turning at lower speeds; 2. Avoid pulling a larger angle of attack at lower speeds. Otherwise, the aircraft may stall.

The Freewing F-14A "TomCat" model jet has successfully incorporated a more advanced, stable and reliable variable sweep wing function into the mid-size aircraft, providing a new choice for consumers who are unable to purchase the dual 80 series F-14 model jet due to limited flight fields, airspace, transportation, cost, and other factors. Finally, thank you again for purchasing this product and wish you a pleasant flight!

Comment:

① Programmable servo, you need to purchase Freewing Blue-Bridge Bluetooth box and download the Freewing Flight Assistant APP to achieve parameter setting function.

② Regarding the results of cruise speed testing, different GPS speed measuring devices and the strength of GPS signals will all affect the speed value. During the testing process, the aircraft will not use climb and dive to achieve greater acceleration. The highest speed value obtained through full level flight.

③ To modify the gyro parameter, you need to purchase Freewing Blue-Bridge Bluetooth box, and connect it to the Type C interface of control board, and download the Freewing Flight Assistant APP to achieve parameter setting function.

## Note:

1. This is not a toy! Operator should have a certain experience, beginners should operate under the guidance of professional players.
2. Before install, please read through the instructions carefully and operate strictly under instructions.
3. Cause of wrong operation, Freewing and its vendors will not be held responsible for any losses.
4. Model planes' players must be on the age of 14 years old.
5. This plane used the EPO material with surface spray paint, don't use chemical to clean, otherwise it will damage.
6. You should be careful to avoid flying in areas such as public places, high-voltage-intensive areas, near the highway, near the airport or any other place where laws and regulation clearly prohibit.
7. You cannot fly in bad weather conditions such as thunderstorms, snows....
8. Model plane's battery, don't allowed to put in everywhere. Storage must ensure that there is no inflammable and explosive materials in the round of 2M range.
9. Damaged or scrap battery should be properly recycled, it can't discard to avoid spontaneous combustion and fire.
10. In flying field, the waste after flying should be properly handled, it can't be abandoned or burned.
11. In any case, you must ensure that the throttle is in the low position and transmitter switch on, then it can connect the lipo-battery in aircraft.
12. Do not try to take planes by hand when flying or slow landing process. You must wait for landing stop, then carry it.

**⚠ NOTE:** This is not a toy. Not for children under 14 years. Young people under the age of 14 should only be permitted to operate this model under the instruction and supervision of an adult. Please keep these instructions for further reference after completing model assembly.

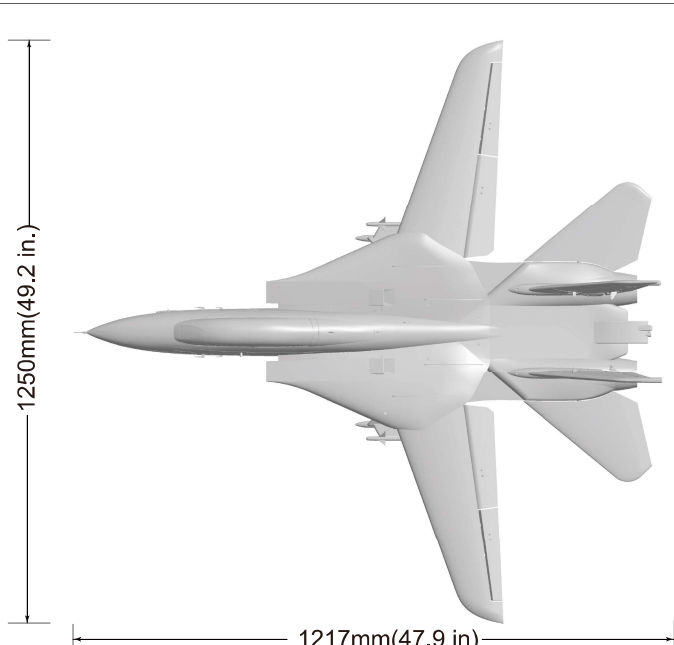

Standard Version

**Wingload:** 244 g/dm<sup>2</sup>  
**Wing Area:** 13.3 dm<sup>2</sup>  
**Servo:** 9g Digital plastic servo ×1  
           9g Hybrid digital servo×7  
           17g MG digital servo×2  
           23g MG digital servo×2  
**Motor:** 2949-2500KV I/R Motor×2  
**Ducted fan:** 64mm 12-blade fan×2  
**ESC:** 60A Brushless×2 (UBEC\*1)  
**Weight:** 2555g(w/o Battery)  
**Li-Po Battery:** 6S 4000-5000mAh

Other features

**Electric landing gear**  
**Nose landing gear cabin door**  
**Scale high LED light set**  
**F-14 Control Board**  
**6 Axis Gyro**  
**Scale pilot**

**⚠ Note:** The parameters in here are derived from test result using our accessories. If use other accessories, the test result will be different. Any problem since of using other accessories, we are not able to provide technical support.

## 产品包装清单

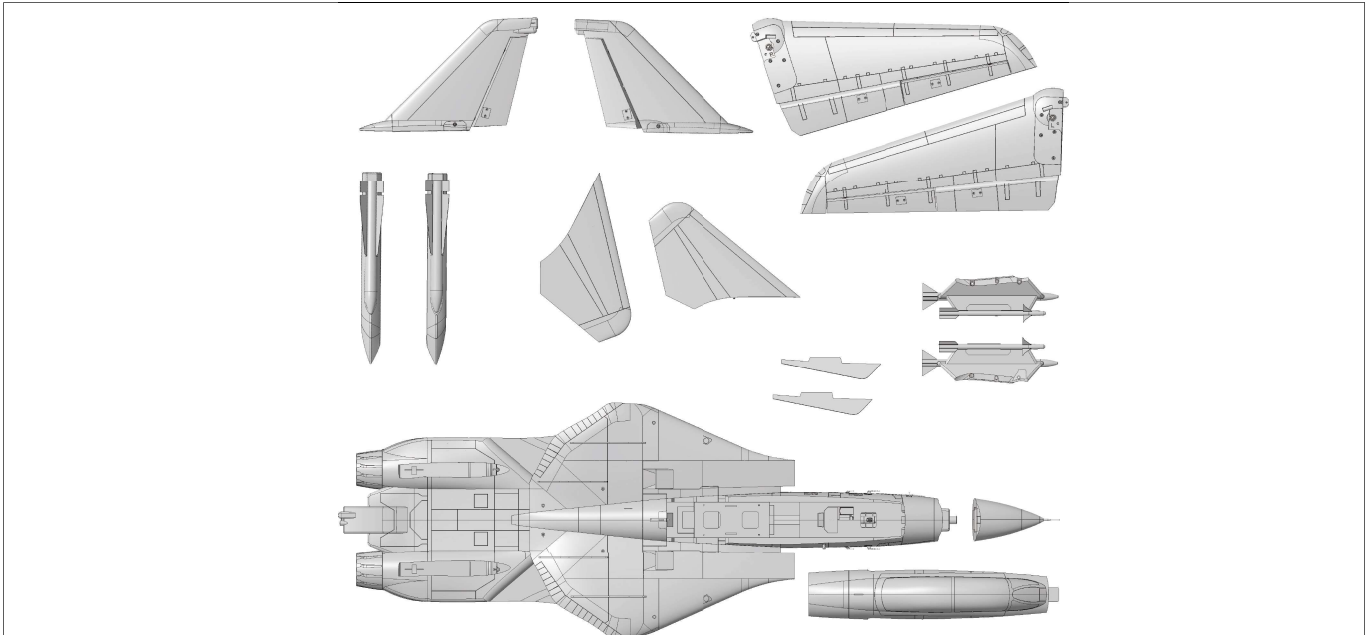

Different equipment include different spareparts. Please refer to the following contents to check your sparepart list.

No.	Name	PNP	ARF Plus	No.	Name	PNP	ARF Plus
1	Fuselage	Pre-installed all electronic parts	Pre-installed servo	6	Cockpit	✓	✓
2	Main wing	Pre-installed all electronic parts	Pre-installed servo	7	Fins	✓	✓
3	Horizontal tail	Pre-installed all electronic parts	Pre-installed servo	8	Annex bag	✓	✓
4	Vertical tail	Pre-installed all electronic parts	Pre-installed servo	9	Missile	✓	✓
5	Nose cone	✓	✓	10	Manual	✓	✓



## Install the Horizontal tail

As the photo show:

1. Turn the fuselage with the belly facing up. Place the horizontal tail fixed ring (screw hole face upwards) to the horizontal tail install slot. Insert it to the rotating shaft of fuselage until it reaches the bottom.
2. Lock the screws on the fixed ring to prevent the horizontal tail to fall off.
3. Repeat the above steps and install the other side horizontal tail.

Screw (HM2\*4mm 2PCS)

**⚠ Attention:** The diameter of the screw here is small, and it can be tightened slightly during the tightening process. Do not use excessive force to cause the screw to slip.

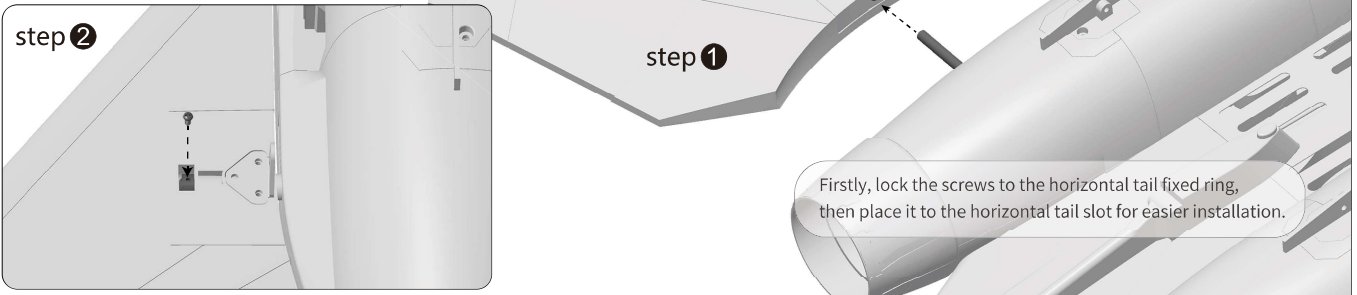

## Install the fins

1. As shown in the following photo, fix the abdominal fins to the belly fuselage with screws.

Screw (KA3×10mm 4PCS)

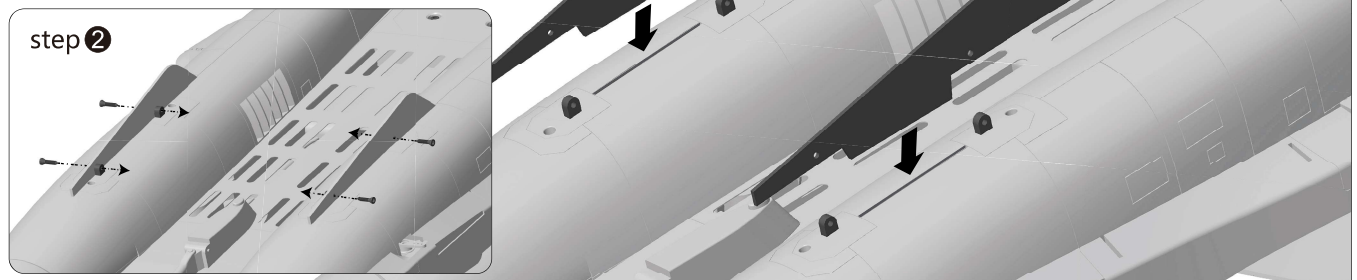

## Install the Vertical tail

As the photo show:

1. Connect the rudder servo and extension cable, then clip the connector into the slot and fix it.
2. Install the vertical tail onto the fuselage, tighten it with three screws.
3. Repeat the above steps to install the vertical tail on the other side.

Screw (KA3X10mm 6PCS)

**⚠ Attention:** 1. When connecting the extension cable, it is necessary to identify the positive and negative terminals and connect them correctly; 2. After the plug is connected, ensure that the plastic clip fully hooks onto the servo cable plug.

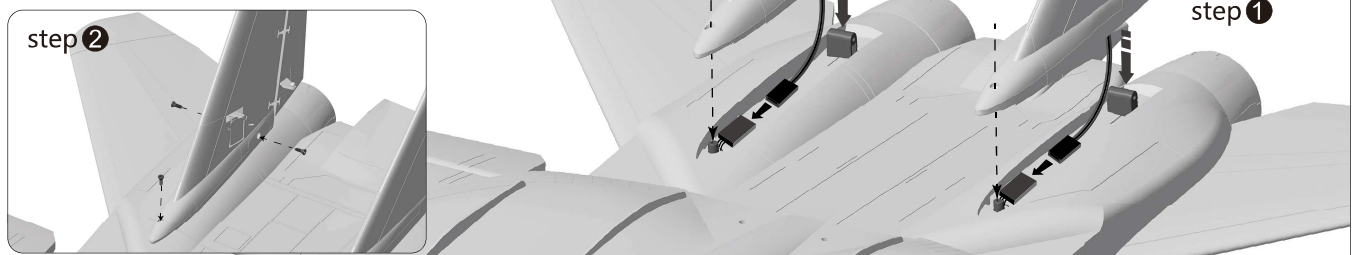

## Install the Main Wing

As the photo show:

1. Before install the main wing, insert an adjusting shim on the rotating shaft of the main wing;
2. After inserting the main wing into the rotating shaft, place an adjusting shim above it.

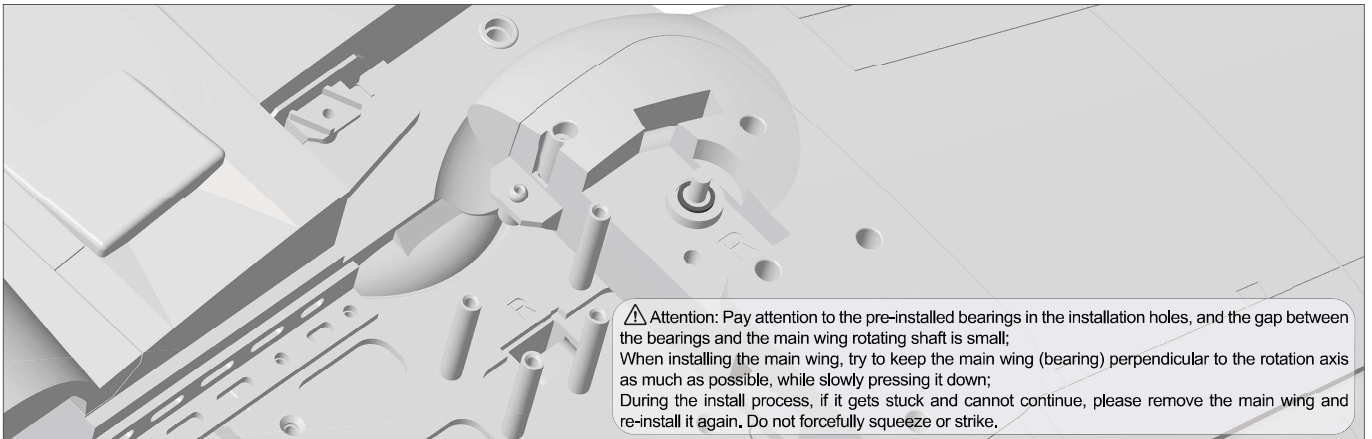
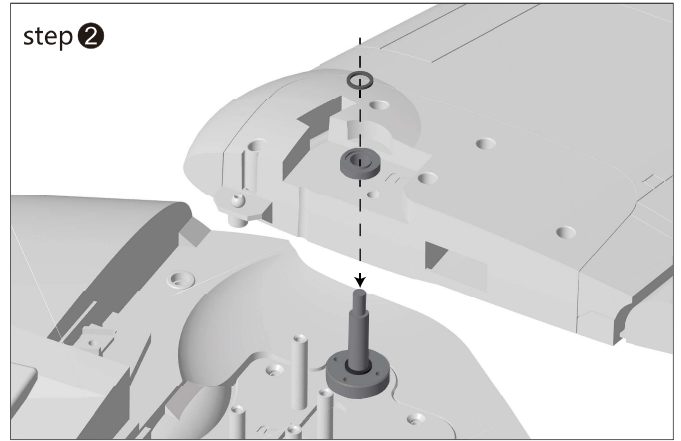
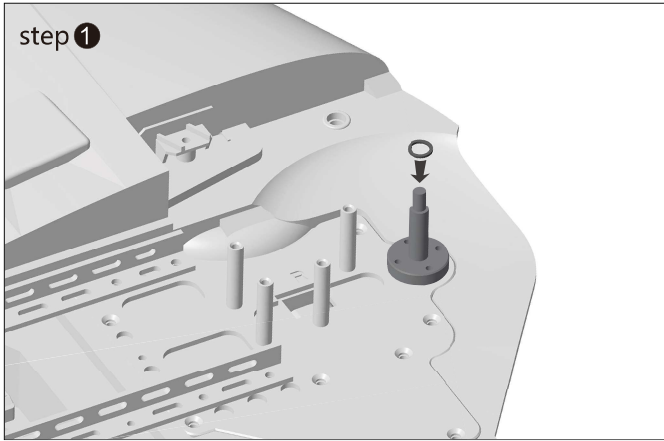

3. After one end of the metal fixed piece is inserted into the main wing rotation shaft, screw in the nut. Adjust the position of the metal fixed piece, confirm that the screw holes of the fixed piece and support rod are aligned, and finally tighten the nut;
4. Screw in the screw hole of the fixed piece A to lock the fixed piece and the support rod.

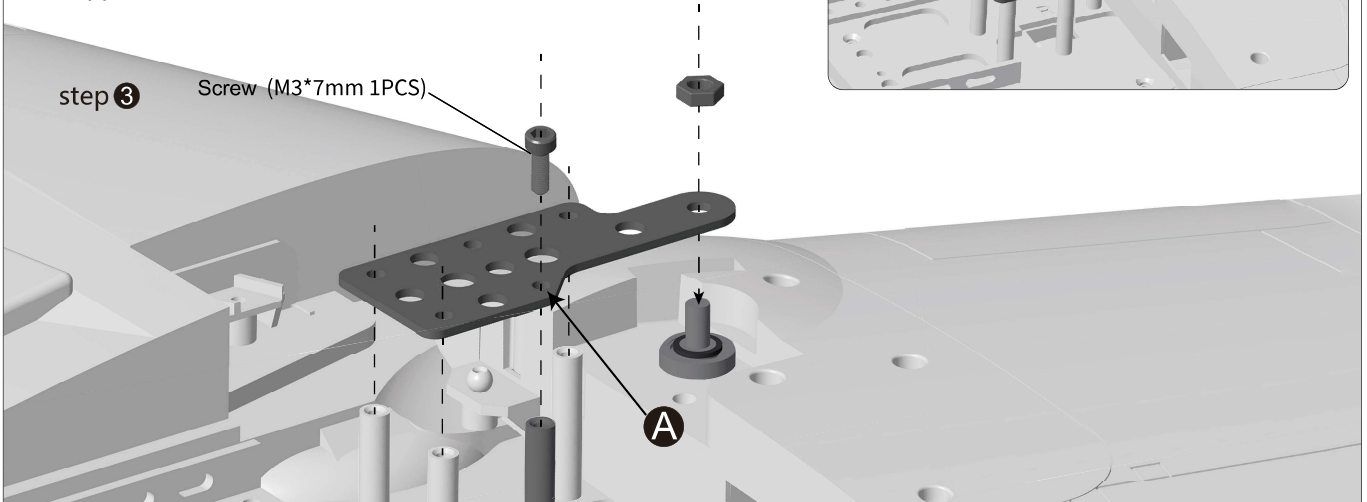
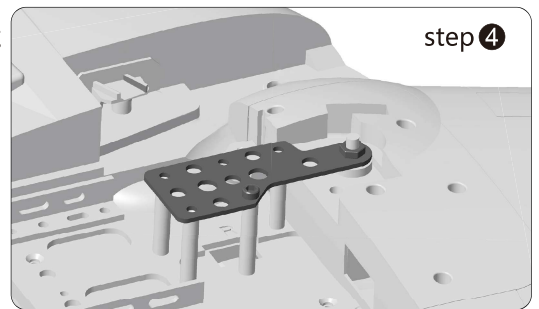

5. As shown in the following photo: Fix the reinforced torsion rod to the swing wing structural component with screws to increase strength

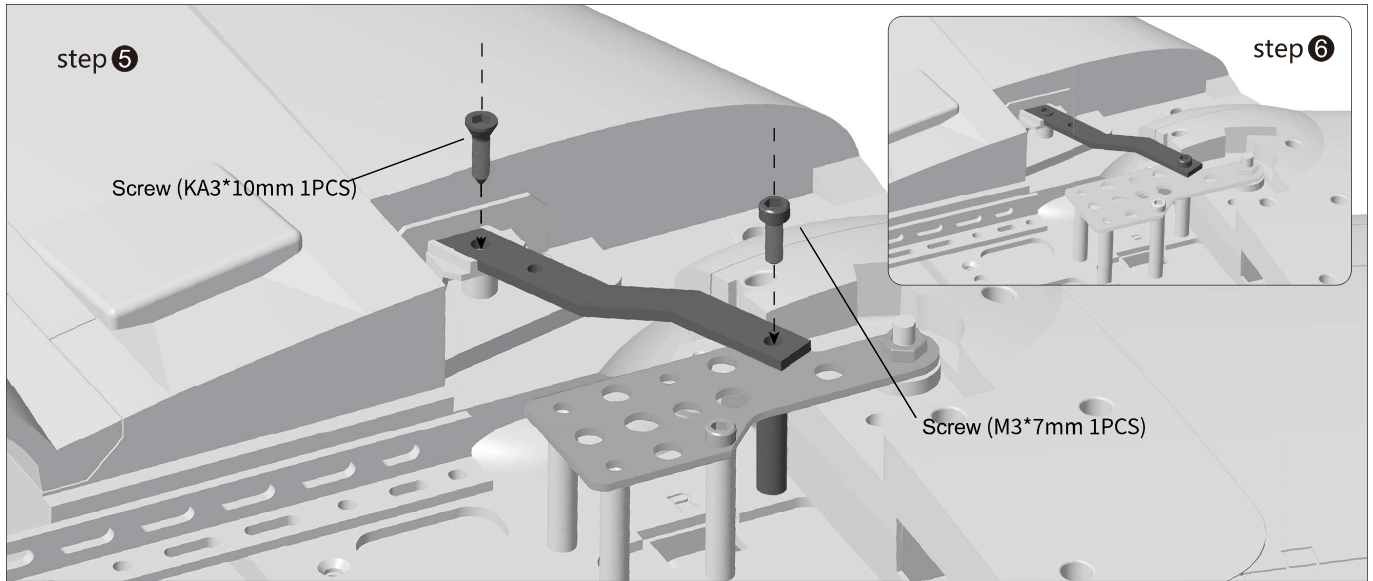

6. As shown in the following photo: Use screws to fix the slant support rod to the swing wing structural component to increase strength;  
 7. Connect the main wing servo cable, LED light cable, and other connecting cables, which are fixed with white plastic buckles, and then extend and connect to the designated channel of the control board (please refer to the introduction of the control board on page 9 for connection);  
 8. Repeat the above steps to install the other main wing.

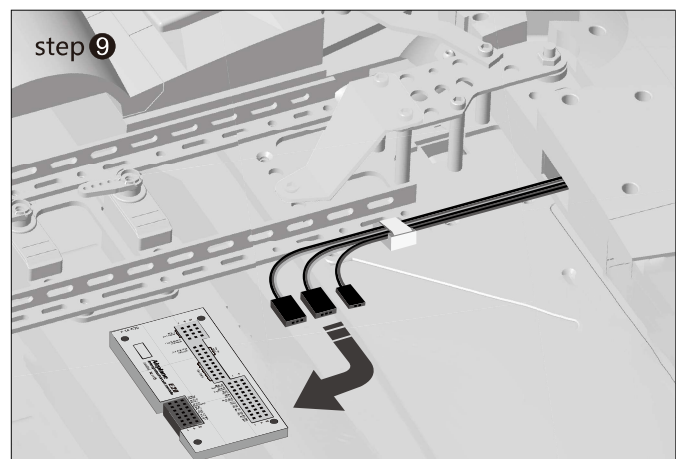
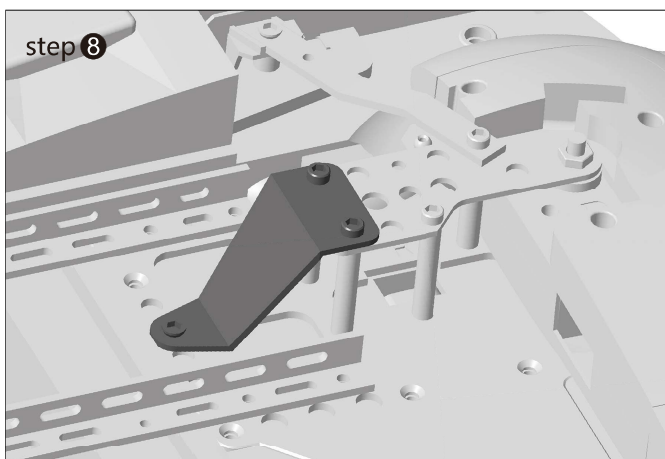
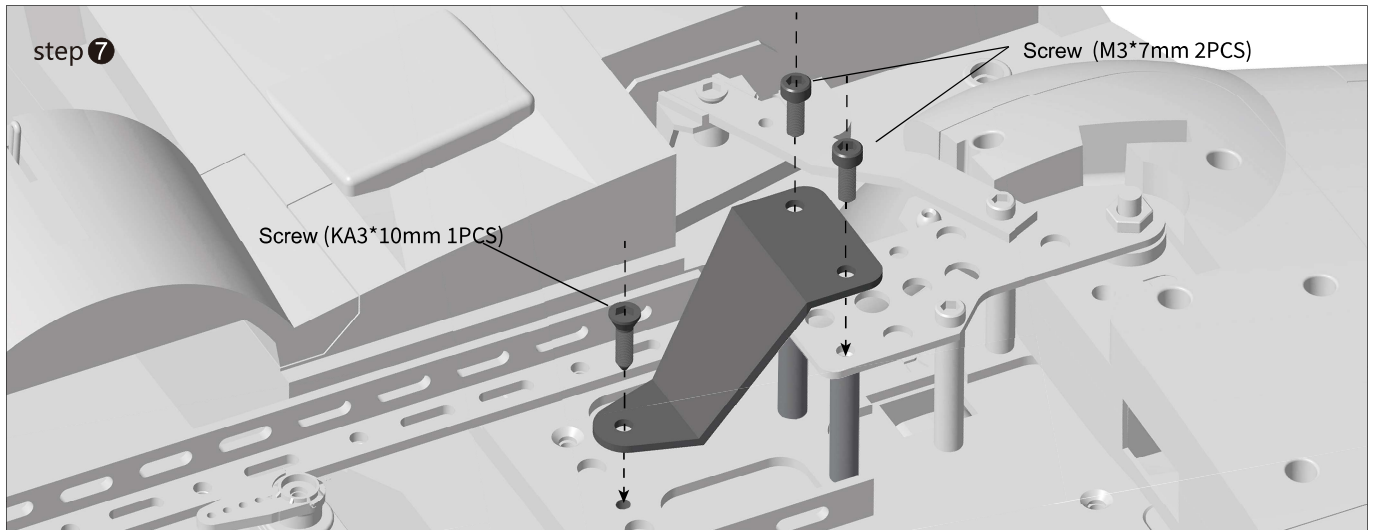

9. After installed the main wing, connected the control board and ESC, and adjusted and tested all electric parts are OK, fix the main wing cover with screws.  
(This step is the last step in the F-14 assembly and adjusting process.)

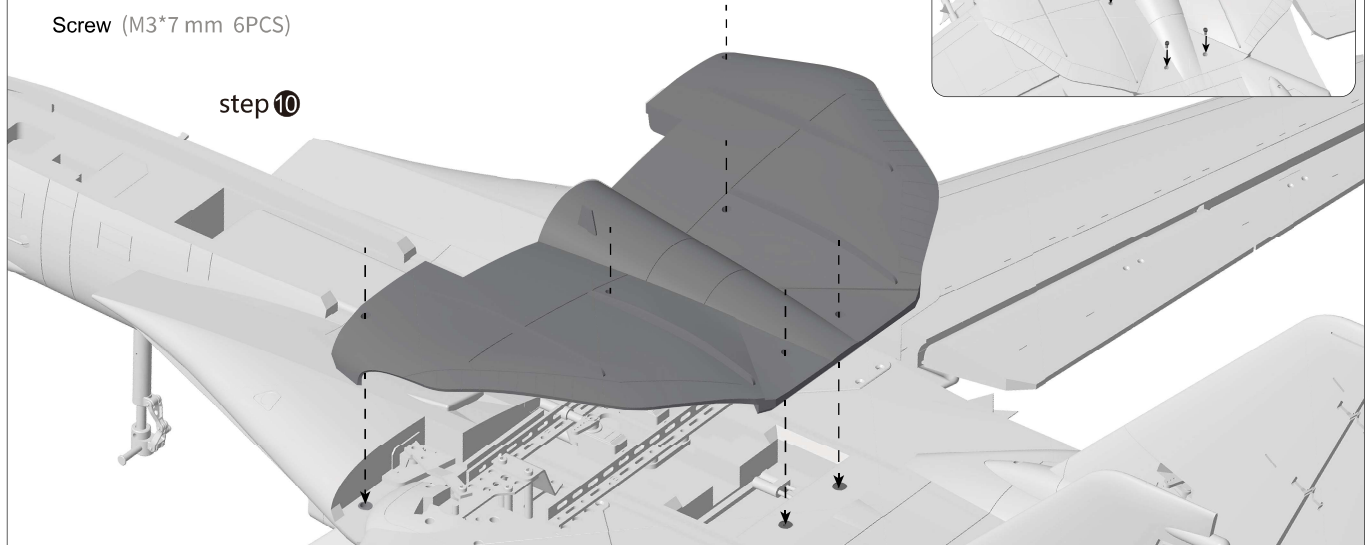

## Install missiles

As the photo show:

1. Fix the missiles mount with screws.
2. Insert the clips on the missiles and bomb models into the fixed slots and push them all the way towards the tail fuselage.

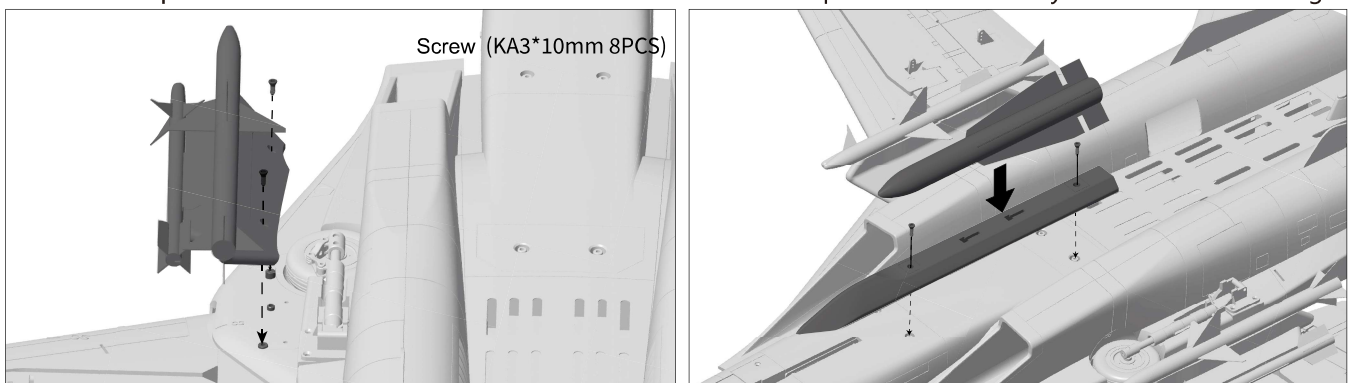

## Install nose cone and decorated parts

As the photo show:

1. Fix the decorated parts on the fuselage by glue.
2. Install the nose cone on the fuselage.

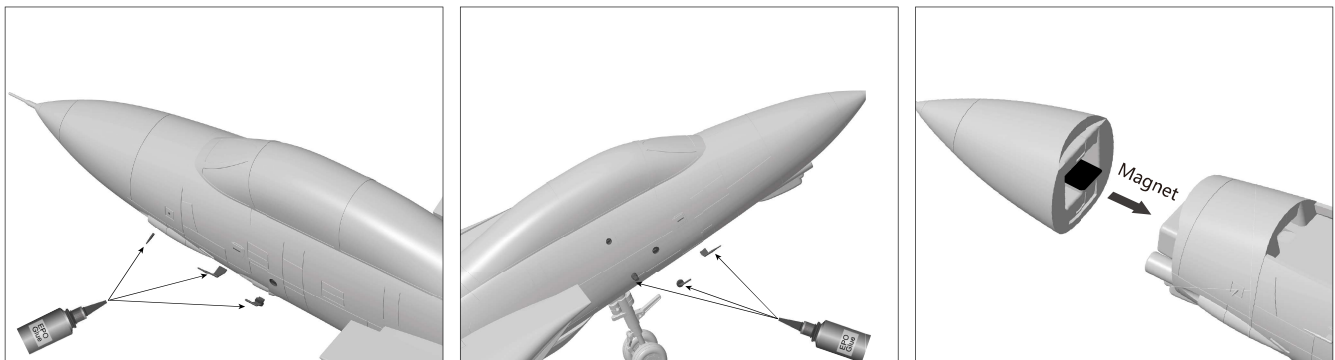



## Install Battery

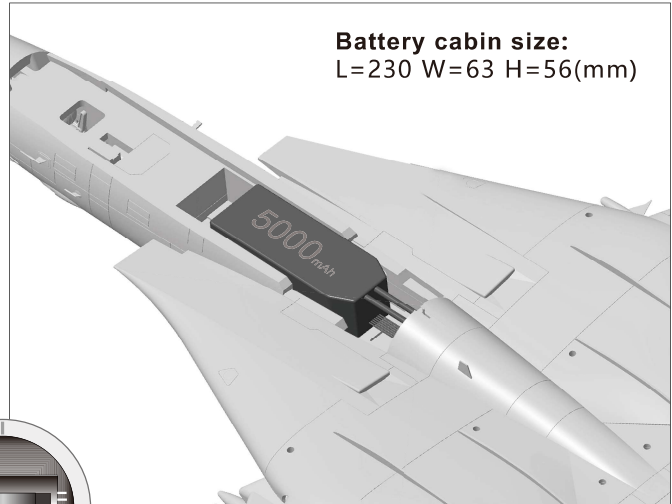
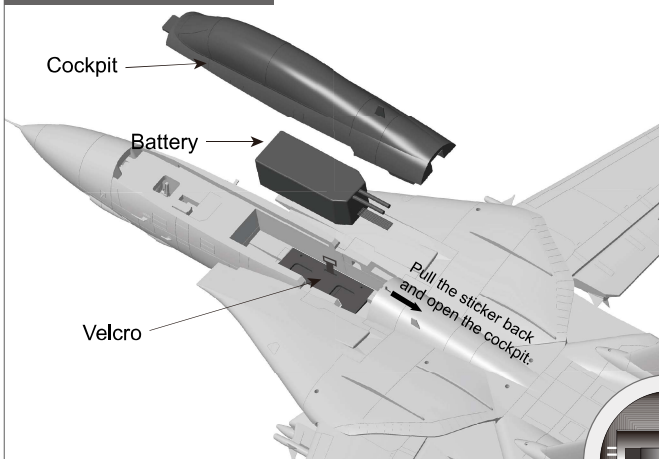

Before connecting the battery and receiver, please switch on the transmitter power and make sure the throttle stick is in the lowest position. Bind your receiver to your transmitter according to your transmitter's instruction manual.

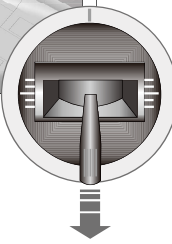

We recommend the following LiPo battery:  
**6S 22.2V 4000mAh~6S 22.2V 5000mAh (1pcs)**  
 Discharge rate of C ≥ 35C

## Pushrod instructions

### Aileron pushrod length

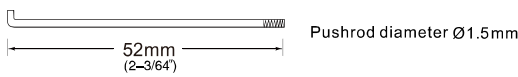

### Aileron pushrod mounting hole



### Flap pushrod length

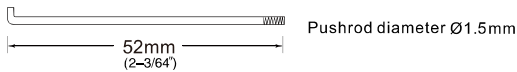

### Flap pushrod mounting hole(Inside)



### Elevator pushrod length



### Elevator pushrod mounting hole



### Swept wing pushrod length

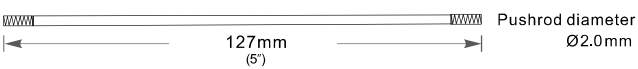

### Swept wing pushrod mounting hole



### Rudder pushrod length

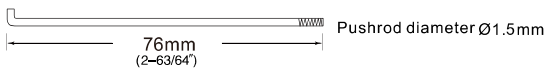

### Rudder pushrod mounting hole



### Nose Cabin door pushrod length

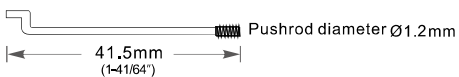

### Nose cabin door pushrod mounting hole



### Nose gear steering pushrod length

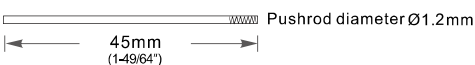

### Nose gear steering pushrod mounting hole

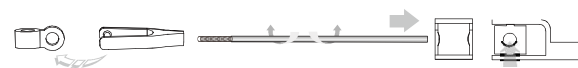



## Important additional notes

The Y-type clevis used in this product is equipped with a transparent silicone ring for secondary reinforcement, which can effectively prevent the clevis from accidentally loosening.

As shown in the following figure, when you buckle the clevis into the control surface horn, use the silicone ring to cover the clevis.

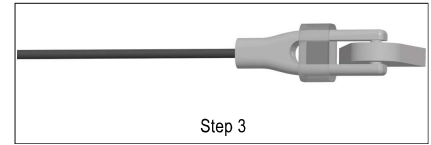
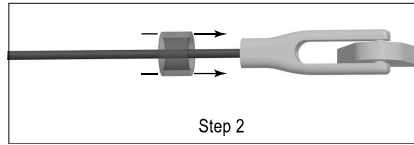
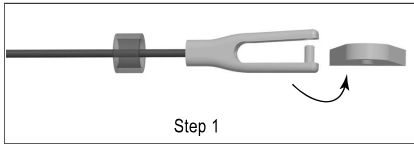

## Center of Gravity

Correct Center of Gravity ("CG") is critical for enabling safe aircraft stability and responsive control. Please refer to the following CG diagram to adjust your aircraft's Center of Gravity.

- Depending on the capacity and weight of your chosen flight batteries, move the battery forward or backward to adjust the Center of Gravity.
- If you cannot obtain the recommended CG by moving the battery to a suitable location, you can also install a counterweight to achieve correct CG. However, with the recommended battery size, a counterweight is not required. We recommend flying without unnecessary counterweight.

As the photo show, We marked the center of gravity on the bottom of the Main wing. Please confirm the CG based on this marked position.

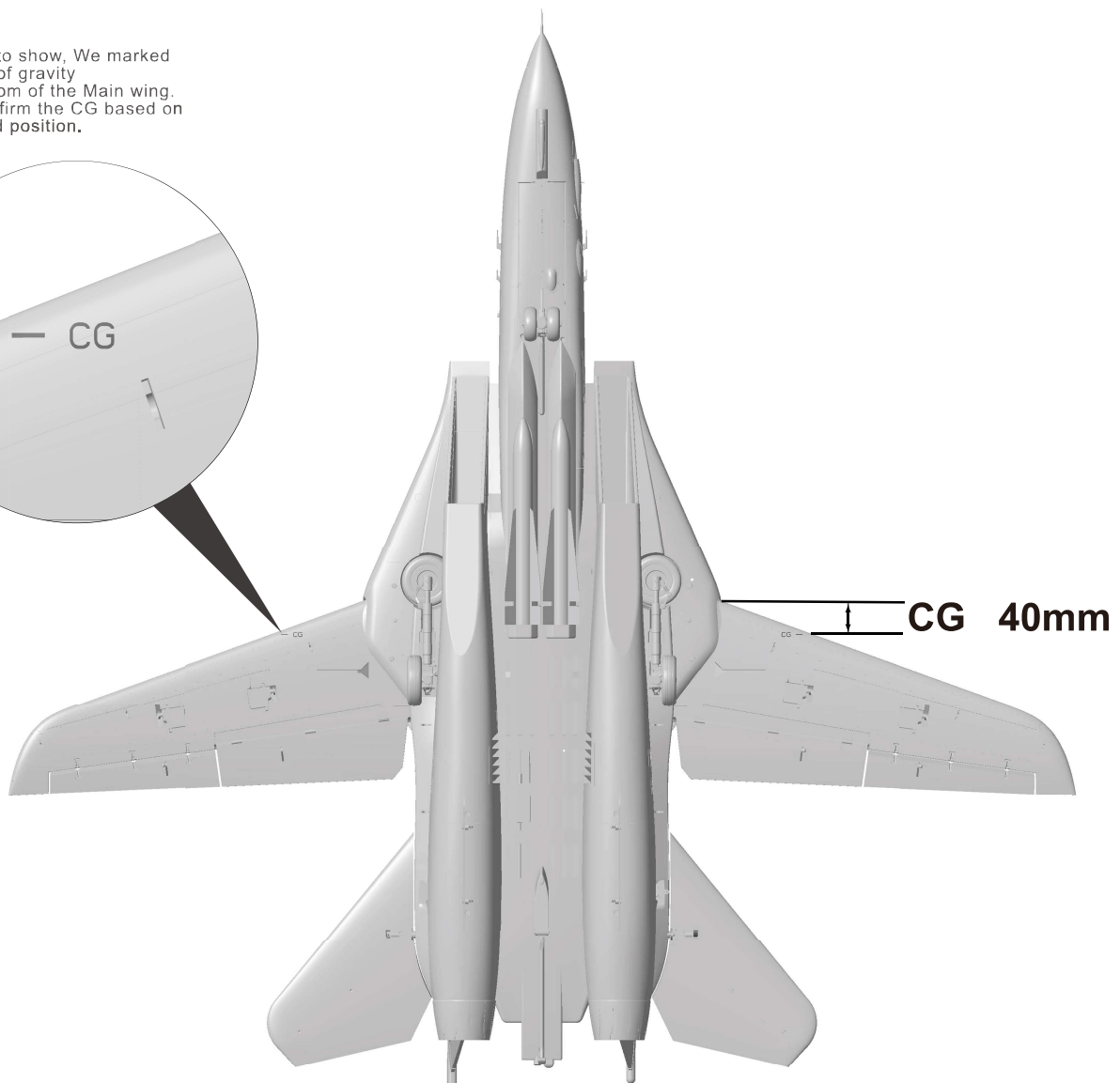

Please refer to the diagram, connect the servo cables to the control board, and connect to the receiver correctly.

- Note:**
1. Ensure that each connecting cable is connected in the correct positive and negative directions;
  2. Ensure that the connecting cable is fully inserted into the row pin without loose;
  3. Ensure that the main wing connection cables do not hinder its swing wing move.

E20 control board pre-set the Flight Guard I gyro program, and pre-set the flight parameters. If you need to modify the gyro parameters, please download the Freewing Flight Assistant APP from the official website ([www.freewingmodel.com](http://www.freewingmodel.com)), through the Freewing Blue Bridge, connect it to the Type C interface of control board, and establish the Bluetooth transmission signal, then modify the parameters in the APP.

**Note:** Freewing Blue Bridge is an encrypted Bluetooth signal transmission device that enables data exchange between apps and electronic devices.

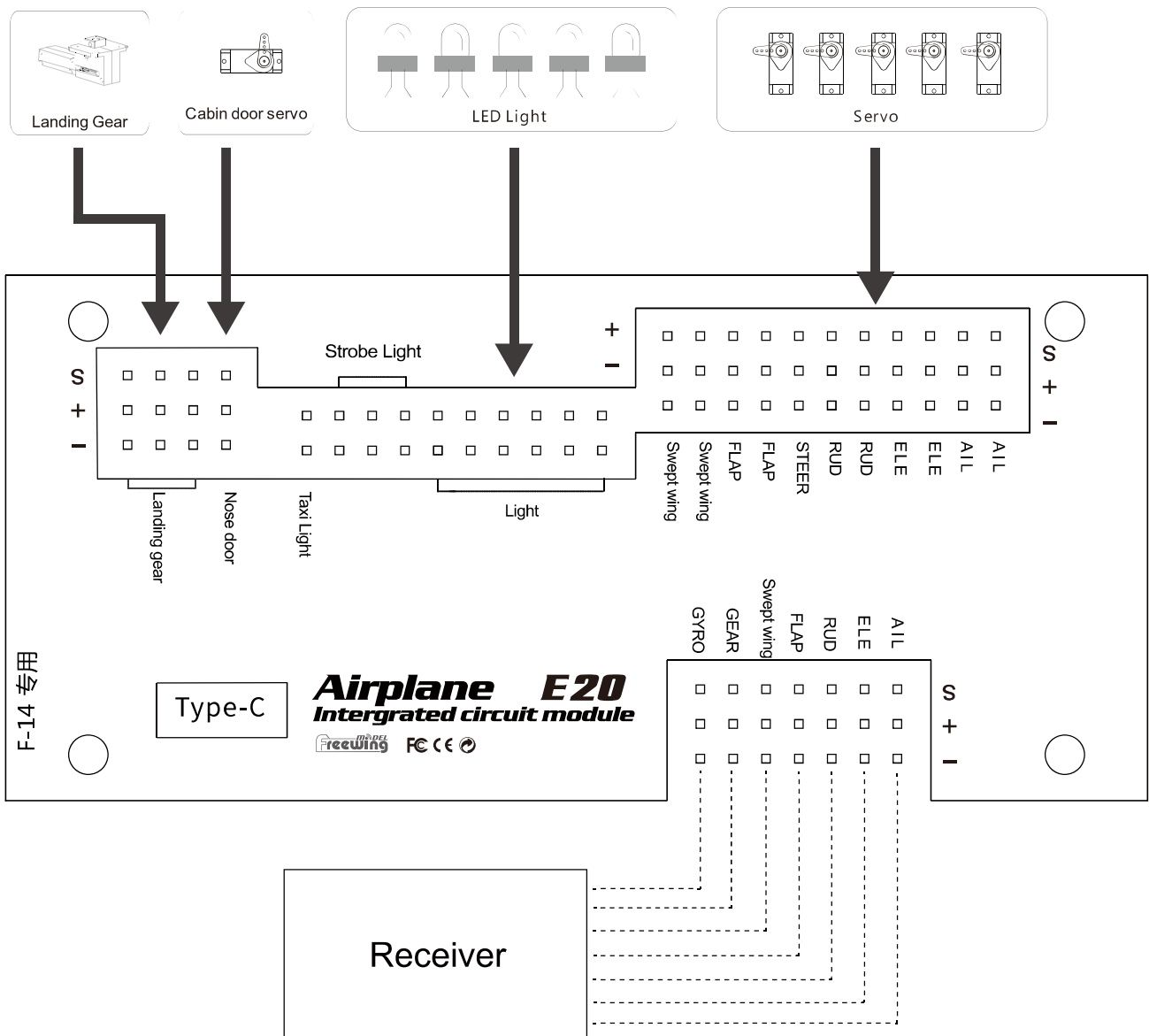

After installed this F-14 model plane, please connect to the receiver and power on, then adjust it.

1. When all channels of radio are fine tuned to zero and the control stick is centered: check whether each control surface on the aircraft is in the center position. If it is found that the control surface is not in the center position, please adjust the control rod to center it;

2. Please refer to the diagram below and use the radio to test each control surface to ensure that its movement direction matches the diagram. If the opposite movement occurs, first check whether the relevant channel in the radio has enabled the reverse function; If the problem persists, please contact us for assistance in resolving it.

### Aileron

Stick Left

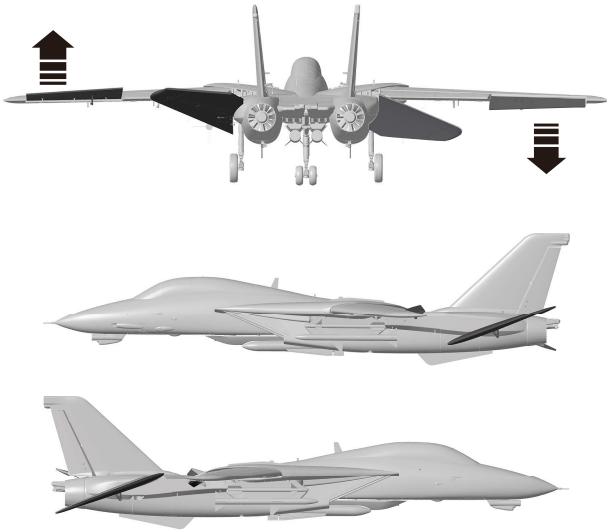

Stick Right

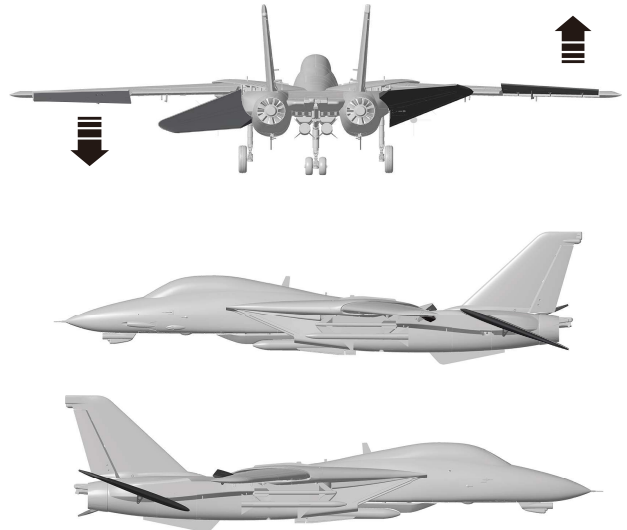

### Rudder

Stick Left

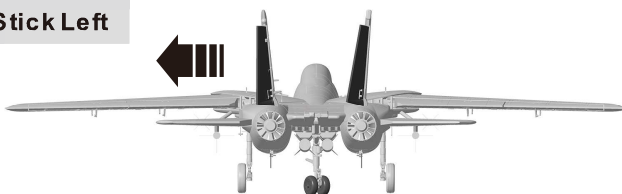

Stick Right



### Elevator

Stick down

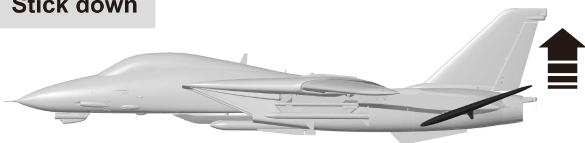

Stick up

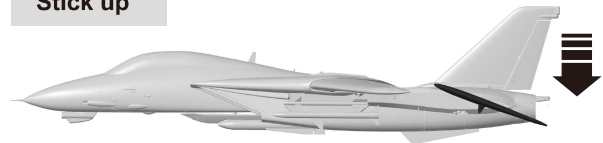

### Flaps

Flaps down

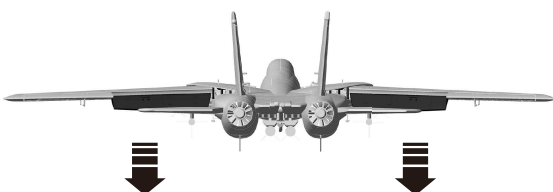

### Swept wing

Swept wing on

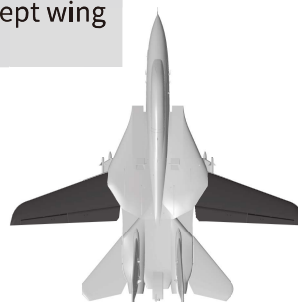

Swept wing off

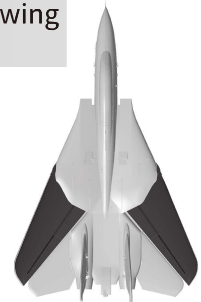

Dual Rates

According to our testing experience, use the following parameters to set Aileron/Elevator Rate. Program your preferred Exponential % in your radio transmitter. We recommend using High Rate for the first flight, and switching to Low Rate if you desire a lower sensitivity. On successive flights, adjust the Rates and Expo to suit your preference.

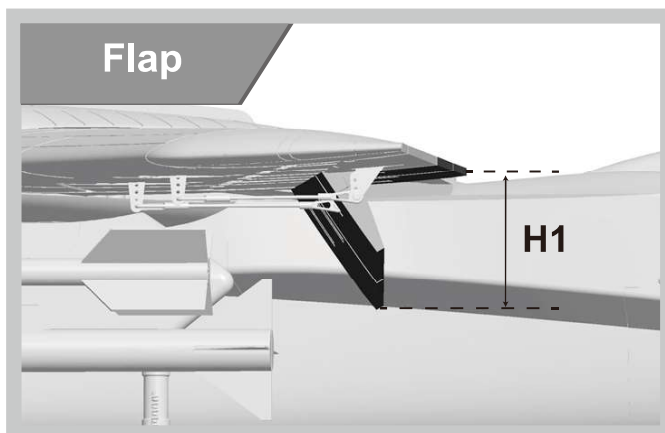
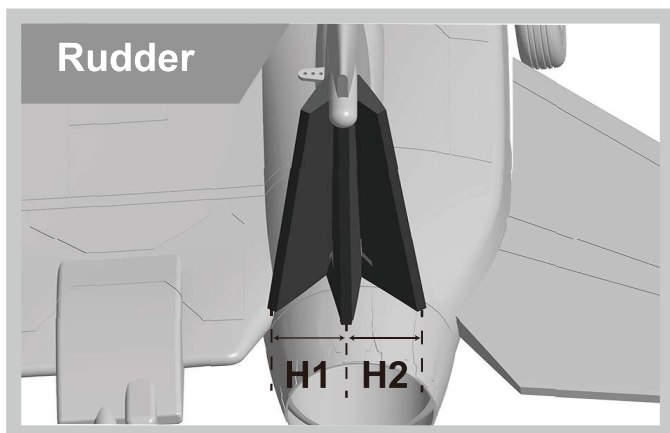
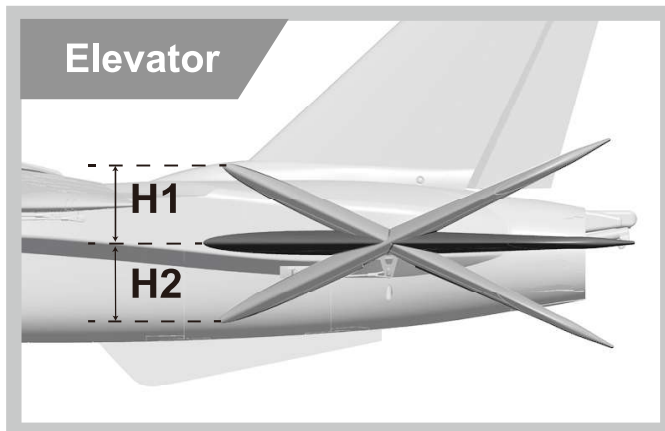
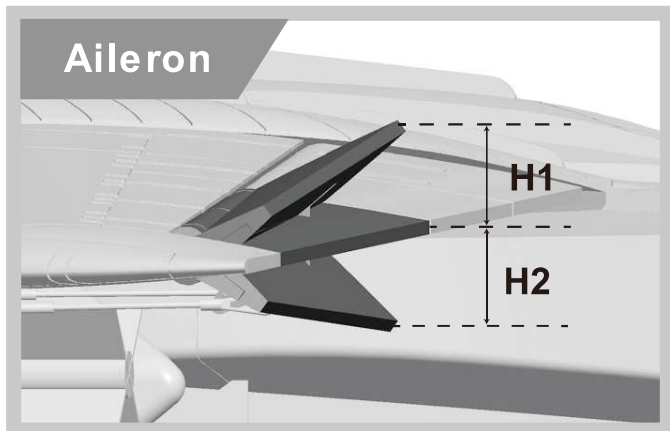

	<b>Aileron</b> (Measured closest to the fuselage)	<b>Elevator</b> (Measured closest to the fuselage)	<b>Rudder</b> (Measured from the bottom)	<b>Flaps</b>
<b>Low Rate</b>	H1/H2 15mm/15mm D/R Rate: 80%	/	H1/H2 24mm/24mm D/R Rate: 80%	H1 11mm
<b>High Rate</b>	H1/H2 19mm/19mm D/R Rate: 100%	H1/H2 26mm/26mm D/R Rate: 100%	H1/H2 28mm/28mm D/R Rate: 100%	H1 19mm

**⚠ Important Flight Notes:**

- The F-14 model jet will meet the obvious nose-up phenomenon when flaps are deployed. A Flap-to-Elevator Mix is required to maintain a good landing when flaps are deployed.

The detail is as below:

With low rate flaps deployed, mix 1mm of DOWN elevator.

With high rate flaps deployed, mix 2mm of DOWN elevator.

- Please refer to the right photo and adjust the flaps and elevator to the correct center position.

Distance from the leading edge of the horizontal tail root (at the forefront position) to the upper surface of the fuselage: 22mm

**Swept wing setting:**

swept wing rate set to 140%

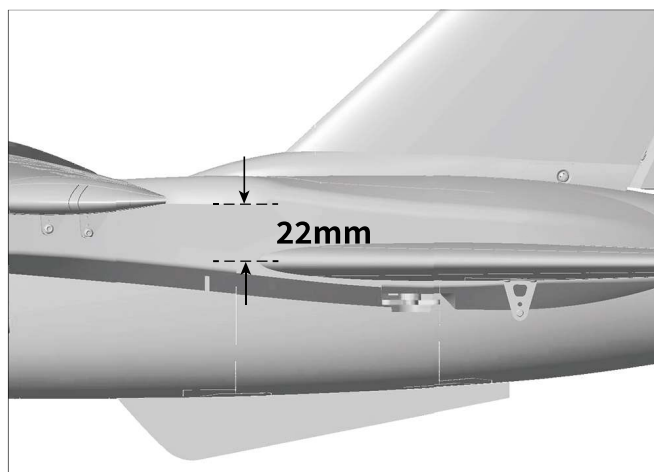

## Remote Control EXP Setting Suggestion

1. Aileron EXP curve is shown as below :

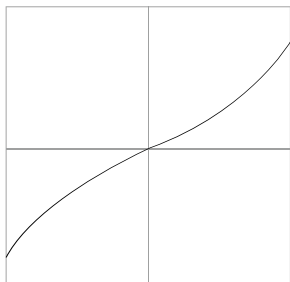

Futaba brand Remote Control : EXP A -30  
EXP B -30

Spektrum brand Remote Control : EXPO 30% 30%

2. Elevator EXP curve is shown as below :

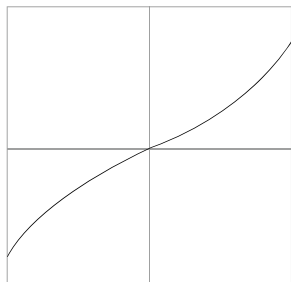

Futaba brand Remote Control : EXP A -30  
EXP B -30

Spektrum brand Remote Control : EXPO 30% 30%

3. Rudder EXP curve is shown as below :

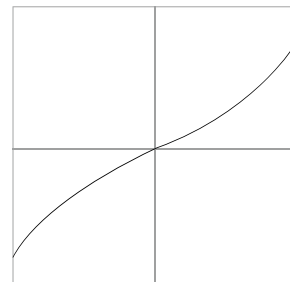

Futaba brand Remote Control : EXP A -30  
EXP B -30

Spektrum brand Remote Control : EXPO 30% 30%

## Servo Direction

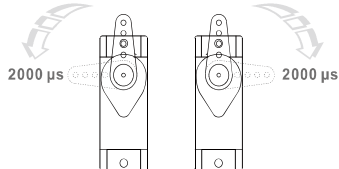

The servo positive or reverse rotation is defined as follows:  
When servo input signal change from 1000μs to 2000μs,  
The servo arm is  
**rotated clockwise, its positive servo.**  
The servo arm is  
**rotated counterclockwise, its reverse servo.**

If you need to purchase another brand's servo, please refer to the following list to choose a suitable servo.

Position	Servo regulation	No.	Pos. / Rev.	Cable length
Nose gear steering servo	9g Digital-Hybrid	1	Positive	600mm
Aileron(L)	9g Digital-Hybrid	2	Positive	500mm
Aileron(R)	9g Digital-Hybrid	3	Positive	500mm
Flap(L)	9g Digital-Hybrid	4	Positive	400mm
Flap(R)	9g Digital-Hybrid	5	Positive	400mm
Elevator(L)	17g Digital-MG	6	Positive	600mm
Elevator(R)	17g Digital-MG	7	Positive	600mm
Swept wing(L)	23g Digital-MG	8	Positive	200mm
Swept wing(R)	23g Digital-MG	9	Reverse	200mm
Nose cabin door	9g plastic servo	10	Reverse	700mm
Rudder(L)	9g Digital-Hybrid	11	Positive	100mm
Rudder(R)	9g Digital-Hybrid	12	Positive	100mm

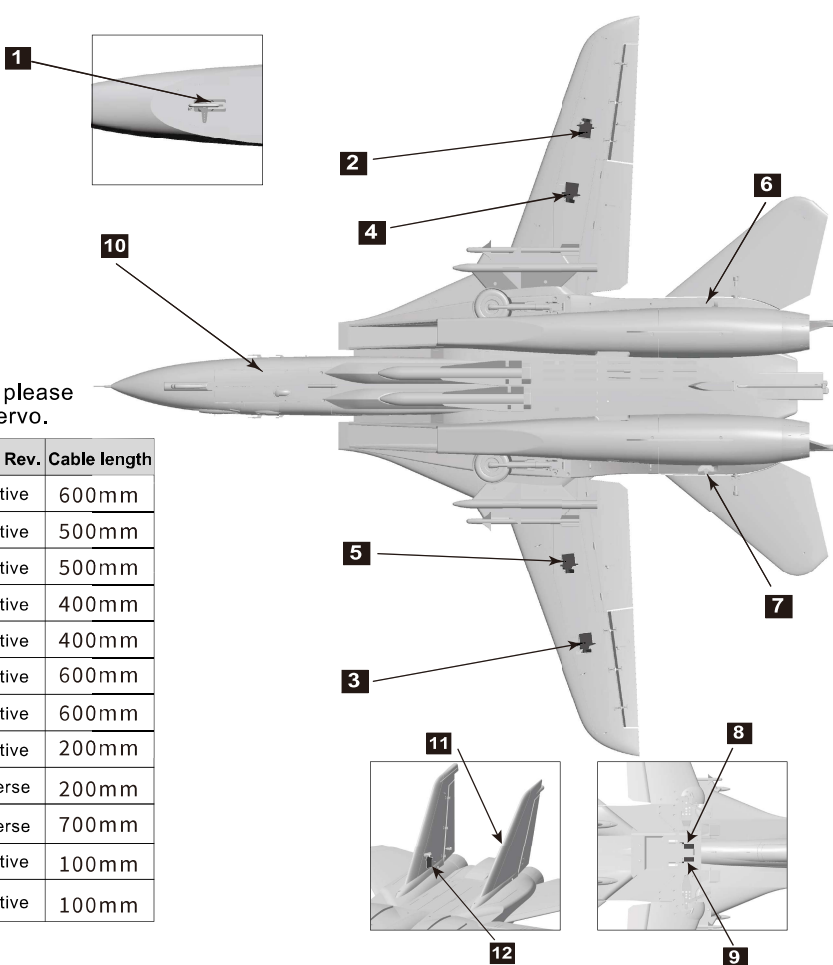

## Motor Specification

2949-2500KV

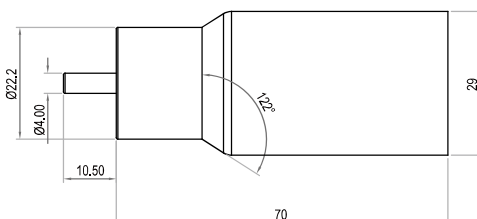
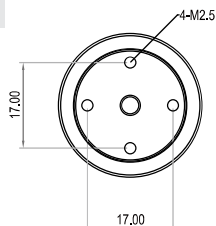

单位: 毫米(mm)

Model	KV Value	Volute (V)	Current (A)	Pull (g)	RPM	Weight (g)	No Load Current	Propeller	ESC
2949-2500KV	2500RPM/V	22.2	63	2029	55500	186	2.7A	64mm Ducted Fan	60A





**Dongguan Freewing Electronic Technology Ltd**  
**HK Freewing Model International Limited**

Add.:FeiYi Building,face to Labor Bureau, Fumin Middle Road, Dalang Town,  
Dongguan City , Guangdong Province, China

Web: <http://www.sz-freewing.com> [www.freewingmodel.com](http://www.freewingmodel.com)

Email:[freewing@sz-freewing.com](mailto:freewing@sz-freewing.com)

Tel: 86-769-82669669 Fax:86-769-82033233

**东莞市飞翼电子科技有限公司**  
**香港飞翼模型国际有限公司**

地址: 广东省东莞市大朗镇富民中路402-408号飞翼楼四楼

Web: <http://www.sz-freewing.com> [www.freewingmodel.com](http://www.freewingmodel.com)

Email:[freewing@sz-freewing.com](mailto:freewing@sz-freewing.com)

Tel: 86-769-82669669 Fax:86-769-82033233

