

Product Update – Freewing Tail Flame Afterburners

Revised August 4th, 2023

Thank you for purchasing a Freewing Tail Flame Afterburner! We want to make you aware of some important information regarding your Tail Flame Afterburner. Please see the details below.

Balance Charging After Each Flight

The Freewing Tail Flame Afterburner only uses 3 cells of the battery it is connected to. This means, at the end of each flight, a slight imbalance will occur with those 3 cells being slightly lower than the others when used in conjunction with 4S or greater LiPo batteries. Be sure to balance charge your batteries after each flight. If installing this system in an actively flown model, please be aware that the Tail Flame Afterburner will draw additional current when in use, slightly shortening your overall flight time. Be sure to adjust your flying time and timer accordingly.

8S Power Systems

To safely connect your Tail Flame Afterburner to your main flight batteries when using an 8S LiPo battery setup, please follow the instructions and images below.

1. Power on your transmitter, and connect your series adapter to the ESC. Connect your batteries to the series adapter and check for proper control function of the model with the transmitter.

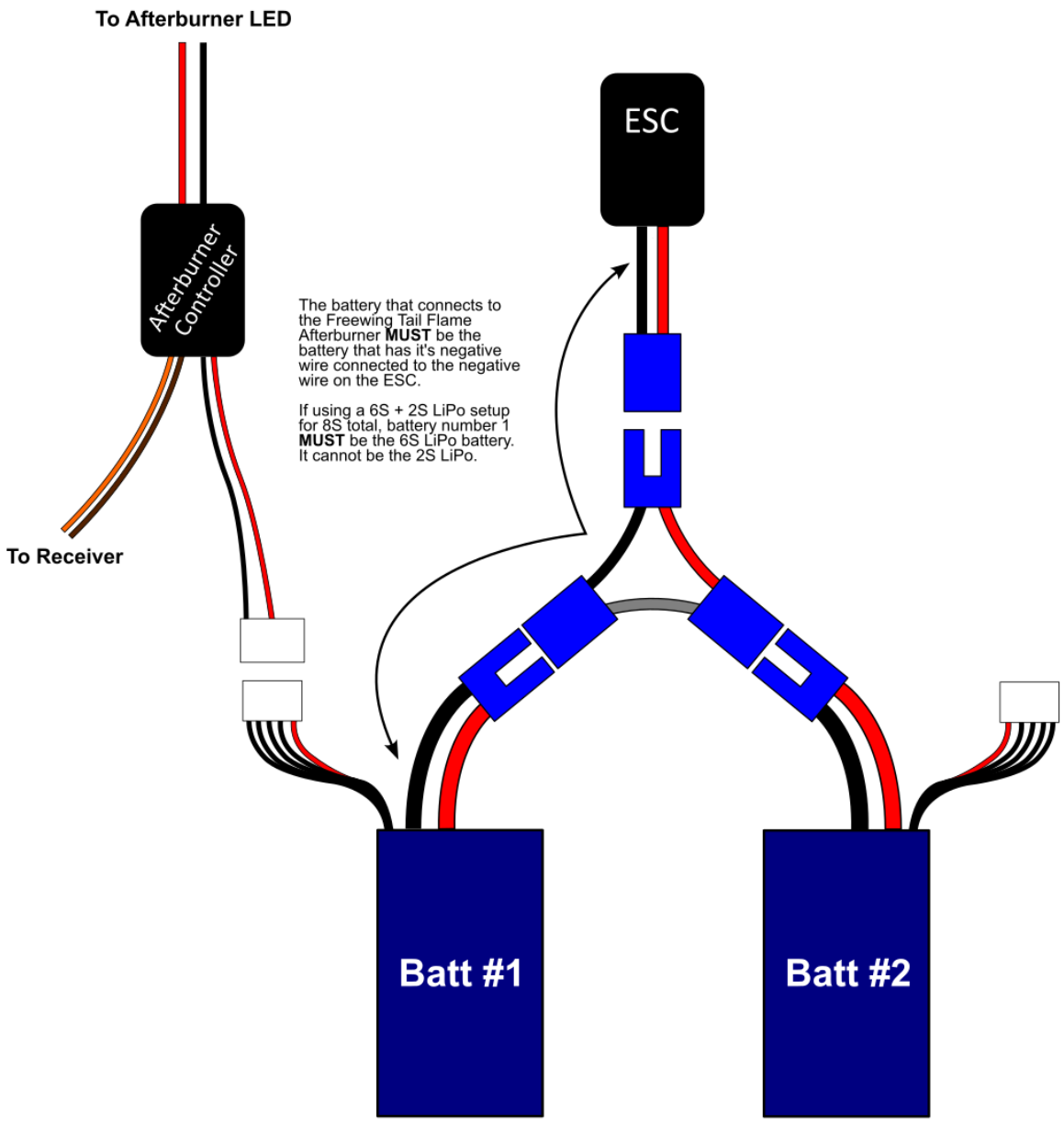

2. Note which battery has its ground (black) wire connected directly to the ESC's black wire and use the balance tab from this battery to connect to the Tail Flame Afterburner. Connecting the other battery's balance tab to the afterburner will cause the system to fail, and potentially cause a fire. If using a 6S and 2S battery in series for 8S, be sure to connect your 6S battery's negative (black) wire to the ESC's negative (black) wire.



On an EC5 to EC5 series adapter, look for the two round parts of the connector that are inline. The battery that plugs its ground wire into this line is battery #1.

On an XT to XT series adapter, look for the two beveled sides of the connector that are inline. The battery that plugs its ground wire into this line is battery #1.

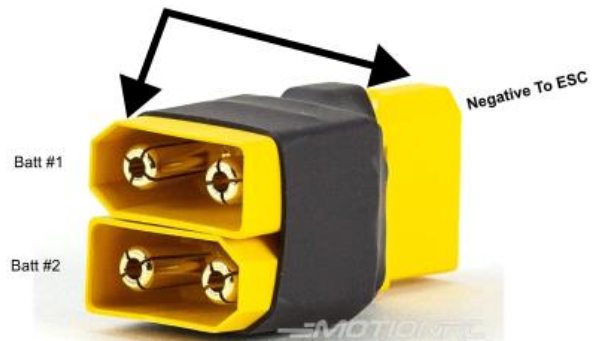

Please reference the image above for another style of series adapter, and how to note which battery to connect to the Tail Flame Afterburner. We recommend using a felt-tipped pen or paint marker to mark which side of the series adapter should be used.

Please note:

- A single 8S LiPo battery cannot be used with the Freewing Tail Flame Afterburner.

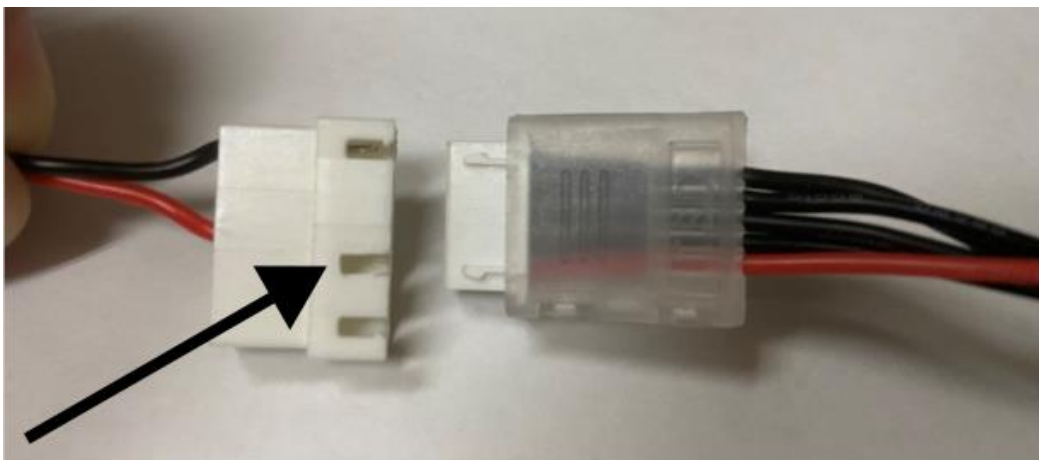

- If using two 4S LiPos, you can cut a small notch in the connector of the Tail Flame Afterburner to allow the 4S balance tab to connect more easily.

