

## INSTRUCTION MANUAL

**THIS MODEL IS NOT A TOY!**

THESE INSTRUCTIONS SHOULD BE READ BY A SUPERVISING ADULT

### WARRIOR V4 2.4GHz RTR

SKU # BNC1036-002

### SMART CAT 2.4GHz RTR

SKU # BNC1063-001

#### CONTENTS OF SET

1) Warrior V4 speed boat  
OR

1) Smart Cat speed boat

2) Transmitter

3) 7.4V Power Pack

4) 2S USB balance charger

5) Boat Stand

6) 4pcs AA batteries (for transmitter)

7) 2.5mm Allen Key (Only For Deep Vee Turn Fins)  
2.0mm Allen Key (for Grub Screws)

8) Radio hanger & screws

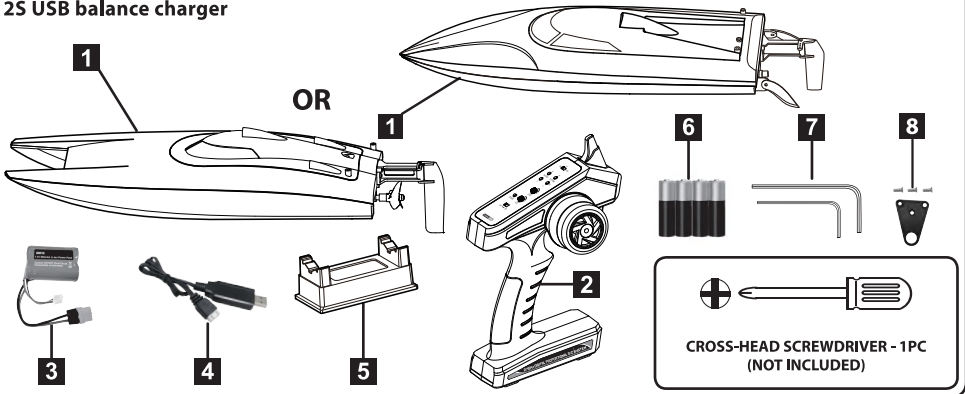

#### Caution for Li-Ion battery:

ESC with low voltage protection, as soon as you notice boat speed slow down obviously, you should drive the boat back to shore and recharge battery. Do not keep playing the boat when ESC low voltage protection active, otherwise, battery will be over discharged and might be damaged and won't be recharged again.

#### Caution:

1. Continuous running of the model will generate high heat levels, Which will lead to premature wear of the motor. Once your power pack is exhausted, we recommend that you open model's upper deck and let motor air cool for around 15 minutes before installing a fresh power pack. This action will protect motor and extend its working life.

2. Before racing your model boat, carefully check silicone tube for guarantee good water cooling system; Avoid water inlet on the bottom of hull become deformed, otherwise, water cooling system failure, this may lead to ESC burned out and motor defected.

#### IMPORTANT

Warrior V4 and Smart Cat are compatible with this manual.

These speed boats are designed for use in fresh water only. They are not designed for use in salt water!

These speed boats are not intended for person under 14 years of age, unless closely supervised by an adult.

## INSTALLING TRANSMITTER BATTERIES

**NOTE:** The transmitter is not water resistant and should never come in contact with water.

1. Install four fresh "AA" batteries. Follow the diagram located in the bottom of the battery tray for proper battery orientation

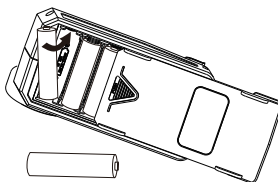

2. Switch on transmitter, transmitter make sound "Bi", LED power light will be flashing.

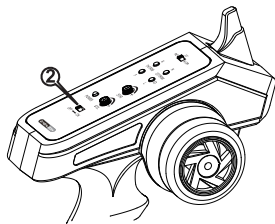

## RADIO HANGER

Triangle radio hanger and 3pcs screw are included in tool bag, use these to hang radio on your neck with ribbon.



## CHARGING THE 7.4V POWER PACK

1) Connect USB balance charger with USB port of computer equipment, mobile phone adapter or power bank. USB charger RED light solid on.

2) Connect battery's charging plug with USB charger's charging port. USB charger RED light solid on, GREEN light flash, this indicate that the battery is charging.

3) A fully discharged battery will take about 4 hours to be fully charged. Do not leave the battery unattended while charging.

4) The RED light turn to be off, GREEN light turn to be solid on when the charge is completed. Disconnect the 7.4V battery from the charger.



**NOTE:** Around 1.5 hours battery charging time, Battery can be charged around 80% capacity, then USB balance charger will continue to charge battery with low charging current, need around 3 hours, USB charger GREEN light turn to be solid on, means battery now is fully charged.

### CAUTION:

1) The 7.4V battery does not come pre-charged. You must fully charge the battery before using the boat

1) The 7.4V battery can be re-charged many times before it needs to be replaced. When the battery no longer holds a charge (is dead), it should be properly recycled.

**NOTE 1:** The boat will run for about 8 mins on a fully charged battery. As soon as you notice a drop off in speed, you should bring the model back to shore to recharge battery or you may lose control of the boat.

**NOTE 2:** Continuous running of the model will generate high heat levels, which will lead to premature wear on the motor. It is recommended to let the model cool down for about 5-10 min before installing a re-charged battery pack.

## INSTALLING THE 7.4V POWER PACK IN THE BOAT

### (Always switch on transmitter before connecting the battery with ESC)

- 1) Remove the boat's upper deck by rotating the plastic lock at its rear section.
- 2) Insert the 7.4V Power Pack into the left side of the hull. The connector of power pack heads towards the front of boat. Tie the power pack with provided magic belt inside the hull.
- 3) Attach the 7.4V Power Pack's connector to the matching connector in the Boat.  
Do not force them together - they only attach one way!
- 4) Re-position the upper deck.

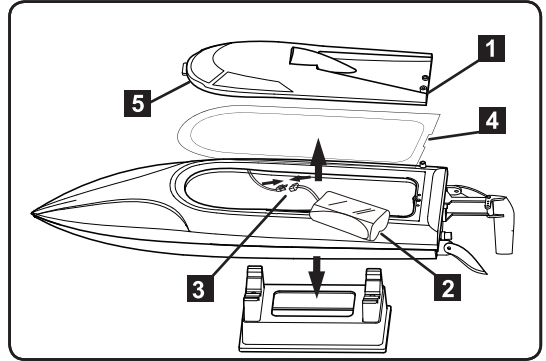

**NOTE:** 1. There is a water proof rubber ring placed along the slot of hull, always make sure it's secured positioned before re-position the upper deck.

## TRANSMITTER/RECEIVER BINDING

transmitter and receiver are automatically binding once they are power on. No need to press any bind button. Just make sure no other transmitter or receiver should be powered on near by.

- 1) Switch on transmitter, transmitter make sound "Bi", LED power light will be flashing.
- 2) Connect battery with boat's ESC, transmitter make sound "Bi Bi", LED power light turn to solid on, now transmitter have automatically bind with boat.

## CHECKING THE RADIO SYSTEM

1. Always switch on the transmitter before connecting the battery with the ESC.
2. Connect battery with boat's ESC
3. Pull the throttle & motor rotate in anticlockwise direction, your motor is now armed and ready for operation.
4. Check the direction of the rudder, the trailing edge of the rudder should turn right when right input is given, Conversely, when left input is given, the trailing edge of the rudder should turn left.

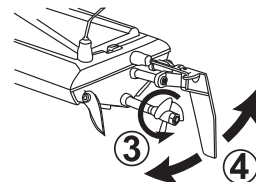
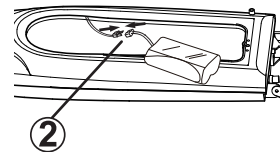
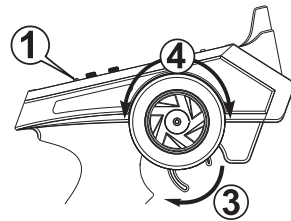

**NOTE:** The left and right steering angle are pre-set as standard angle to suitable for common boat driving style. If you want to change the turning radius, you can adjust the two knobs on transmitter "ST/R", "ST/L". more detail information refer to "EPA ADJUSTMENT".

## WARRIOR TURN FINS & SELF-RIGHTING

Warrior V4 features adjustable turn fins to aid in turning. These can be adjusted using the included Allen key. The optimum angle of adjustment is 45 degrees to the hull.

Warrior V4 deep vee boat designed with self-righting function. When boat accidentally capsizes in fast speed and big wave driving, no worries, pull the throttle trigger, boat will automatically self-righting and you can drive the boat again.

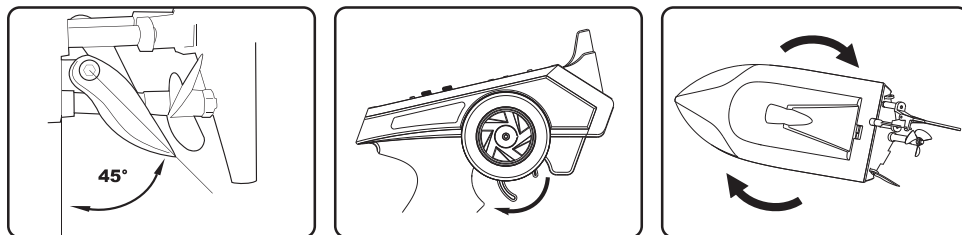

## DRIVING YOUR BOAT

- 1) Switch on transmitter, transmitter power LED light flash.
- 2) Check that the Warrior's turn fins are adjusted correctly.
- 3) Switch 'ON' the boat (connect the 7.4V Power Pack).
- 4) Check that the propeller and the rudder respond to transmitter inputs before placing the Boat on the water.

### AFTER USE

- 1) When you have finished using your Boat, you should first switch 'OFF' the model (disconnect the 7.4V Power Pack), then switch 'OFF' your transmitter.
- 2) Remove all batteries from the transmitter and model.
- 3) Leave the Boat's upper deck off to allow moisture to evaporate. Ideally, place the model in this way in a warm and dry place, like an airing cupboard, until you are sure it is dry and then store it away.

**NOTE:** If the Boat begins to bob when running, it may have taken on an excessive amount of water. In this case, you should immediately return to shore, remove the upper deck and drain the water from the hull.

## TRANSMITTER INTRODUCTION

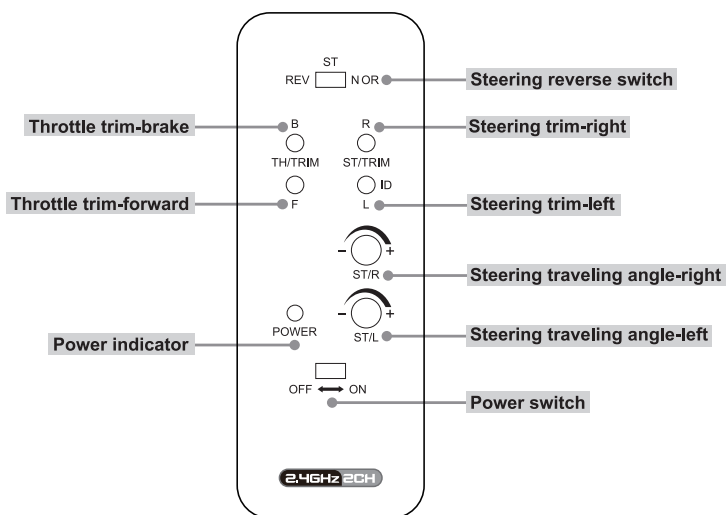

## EPA ADJUSTMENT

### Function

Use this when performing left and right steering angle adjustments. End Point Adjustment (EPA) adjusting value range: 0%-100%

### Setting

1. Steering (right side) angle adjustment Rotate "ST/R" knob to the left end point means minimum value 0%, right end point means maximum value 100%.
2. Steering (left side) angle adjustment Rotate "ST/L" knob to the left end point means minimum value 0%, right end point means maximum value 100%.

### CAUTION:

When adjusting this function, make sure the direction is in agreement with the boat direction, you can adjust by the STEERING "REV-NOR" button.

### Steering reverse switch

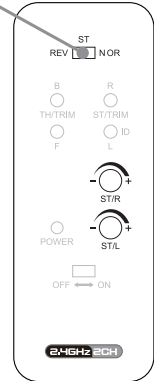
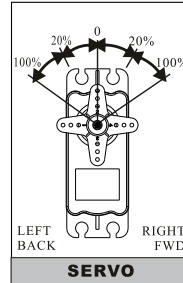

## TRIM ADJUSTMENT

### Steering trim

Adjust "ST/TRIM" "R/L" so that rudder is centered prior to operation, you may adjust this control to make the boat run straight during operation.

### CAUTION:

When adjusting steering trim, make sure the direction is in agreement with the boat direction, you can adjust by the STEERING "REV-NOR" button.

### Throttle trim

Adjust "TH/TRIM" "B/F" to stop propeller from turning while the throttle trigger is in the neutral position.

### Steering reverse switch

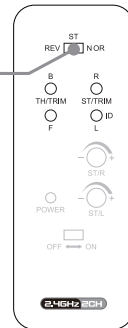

## LUBRICATING DRIVE SHAFT

Lubricating the flexshaft is vital to the life of the drivetrain. The lubricant also acts as a water seal, keeping water from entering the hull through the stuffing tube. Lubricating the flexshaft, propeller shaft after every 2 or 3 times of operation.

1. Use the 2mm Allen key to loose the two grub screws of the coupler which connects the flexshaft, then slide the flexshaft w/ prop shaft out of the stuffing tube.
2. Lubricate the flexshaft w/ prop shaft with the water proof marine grease, reinstall the flexshaft w/ prop shaft in reverse order, be sure to retighten the two grub screws of coupler.

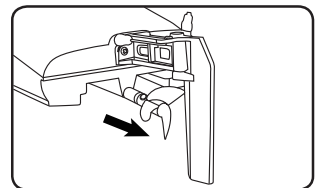
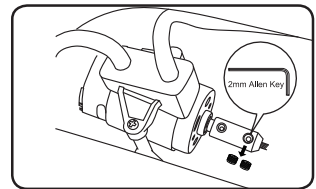

## CAUTION!

**Please observe the following warnings.**

### DURING OPERATION

- The transmitter's range will vary depending on your surroundings and battery strength. Do not operate Boat too far away or control will be lost.
- Ensure that all batteries are correctly installed and that the 7.4V Power Pack is fully charged.
- Do not operate your Boat in areas with strong currents, in salt water or areas of water with large waves.
- Do not touch moving parts during operation, especially the propeller.
- Do not let your Boat run aground, as this can cause damage.
- If you lose control of your Boat, never wade into deep water or water with strong currents to retrieve it. First, hold the transmitter as high as you can to try to re-establish control. If this does not work, find another way to move closer to the model, but do not endanger yourself in the process!

## CARE WITH RECHARGEABLE BATTERIES (THE POWER PACK)

Care must be taken when handling rechargeable batteries (the Power Pack) to avoid the possibility of injury and/or damage to property. Do not short circuit, disassemble or incinerate rechargeable batteries. It is very dangerous to disregard these warnings.

### GENERAL INFORMATION FOR THE SAFE OPERATION OF YOUR BOAT

**Please follow these simple rules to ensure safe operation and gain the maximum enjoyment from your model.**

- Avoid overloading your model. Never run it in areas where its movement will be restricted, e.g. areas where there is pond weed, etc., as this can over stress the motor.
- Ensure nothing prevents the smooth running of moving parts.
- Do not run your model in confined spaces.
- Never run your model in a public space where it might upset or endanger people or wildlife.
- Immediately switch 'OFF' your model and transmitter if you see lightning or hear thunder. Never use your model in the rain.

Do not dismantle or tamper in any way with this R/C vehicle and its transmitter. The manufacturer and distributor will accept no responsibility, expressed or implied, for accidents or injuries caused as a result of disassembly, modification and/or usage against the Instructions for this product.

Tampering or modification will also invalidate the guarantee.

## TROUBLE SHOOTING

Check using the chart below before returning your Boat for repair as many problems can be easily solved.

PROBLEM	CAUSE	REMEDY
Model will not move	No battery in transmitter/model Battery installation is incorrect Weak battery in transmitter Weak batteries in model	Install batteries Install batteries correctly Install a fresh battery Recharge 7.4V Power Pack
No control of model	Weak battery in transmitter	Install a fresh battery
Limited radio range	Weak battery in transmitter	Install a fresh battery

**SPARE PARTS**

<b>Part No.</b>	<b>Part Name</b>
BNC5059-005	Bancroft Aluminum Coupler w/ 3 Screws
BNC7008-002	Bancroft Deep-Vee Flex Shaft Set
BNC1035-102	Bancroft Searider V4 Flex Shaft Set
BNC7007-001	Bancroft Rudder Set
BNC7007-002	Bancroft Stainless Steel Turn Fins Set
BNC6000-007	Bancroft Brushed 390 Motor
BNC6024-002	Bancroft 800mAh 2S 7.4V Li-ion Battery with XT60 Connector
BNC5059-002	Bancroft Aluminum Alloy Motor Coupler with 3 Screws
BNC1031-103	Bancroft Gear Box Set Without Metal Gear
BNC5077-003	Bancroft P1.4 x 30mm Two Blade Nylon Propeller (PK2)
BNC6008-008	Bancroft J2C96 2.4GHz 2CH pistol-grip transmitter
BNC1031-100	Bancroft 390 motor with metal gear
BNC6005-012	Bancroft 9g rudder servo(235mm wire)
BNC6026-002	Bancroft 2S USB balance charger
BNC5077-002	Bancroft 1.4 X 35mm $\Phi$ 3.1mm Two Blade Nylon Propeller (Pk2)
BNC6004-005	Bancroft ESC/Receiver combo set-Mad Shark V3, Warrior V4
BNC1036-101	Bancroft Warrior V4 deck(No decal) & rubber ring
BNC1035-101	Bancroft Searider V4 Plastic Lock Knob
BNC1063-100	Bancroft Smart Cat Deck/Rubber Ring
BNC1033-114	Bancroft Super Mono X Plastic lock knob with screw for deck

**NEED SPARE PARTS OR TECHNICAL SUPPORT?**

In USA, visit [www.motionrc.com](http://www.motionrc.com) or call (224) 633-9090

In EU, visit [www.motionrc.eu](http://www.motionrc.eu) or call +31-30-8080557



*Scan for customer and technical support*



*Scan for warranty information*



*Scan to see the entire assortment of Bancraft boats*

©2023 Motion RC, LLC

Printed in China



**FCC REQUIREMENT**



This device complies with Part 15 of the FCC Rules. Operation is subject to the following two conditions: (1) This device may not cause harmful interference, and (2) This device must accept any interference received, including interference that may cause undesired operation.

**CAUTION:** Changes or modifications to this product not expressly approved by the party responsible for compliance may void the user's authority to operate the equipment.