



Avanti S V2

USER MANUAL

WINGSPAN: 1236MM (48.7 in)

LENGTH: 1300MM (51.2 in)

80mm EDF Sport Jet

DESIGN APPROVED BY SEBASTIANO SILVESTRI

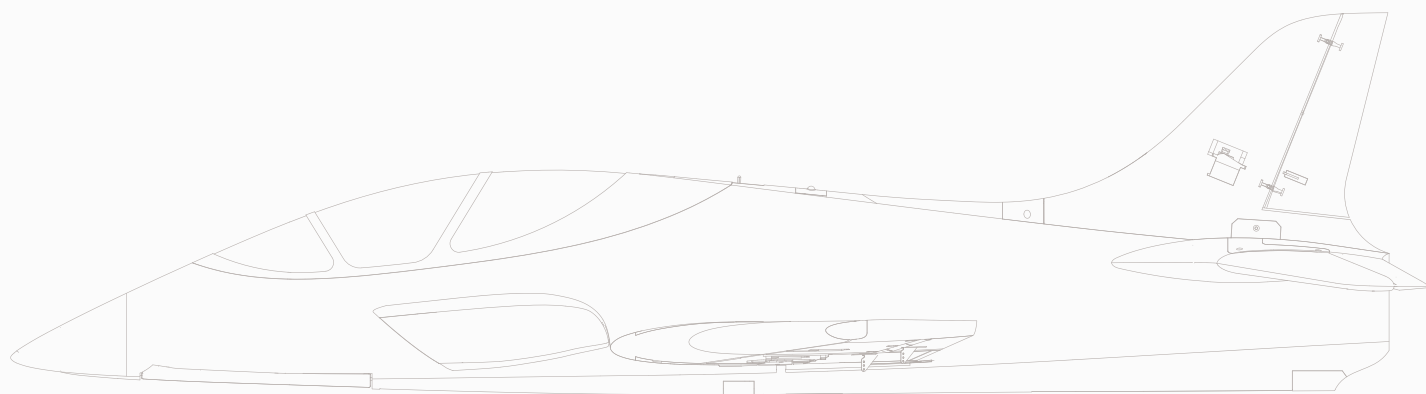

EN

1~12

中

13~24



www.sz-freewing.com

MADE IN CHINA

Thank you for purchasing our Freewing 80mm EDF jet Avanti S, this original jet is designed from the famous Italian F3A world champion Sebart, a fiberglass turbo jet. We got Sebart's authorization, and design approved by Sebastiano silvestri, we re-design it as a small good electric sport jet, let more customers enjoy this excellent jet. New Avanti S use EPO material, length is 1300mm, wingspan is 1236mm. Use the control board, is easier for assemble/disassemble and easy to carry. And new Freewing 80mm 12-blade EDF power system with 100A ESC can bring you very strong power in flight.

Avanti S has excellent flight stability and easy to operate kinds of F3A aerobatics. When landing in low speed, it can keep very stable and the player can operate easy and gentle landing. This Avanti S electric sport jet model suit for the players who love aerobatics, also it is an excellent primary trainer of EDF jet.

⚠ NOTE: This is not a toy. Not for children under 14 years. Young people under the age of 14 should only be permitted to operate this model under the instruction and supervision of an adult. Please keep these instructions for further reference after completing model assembly.

Note:

1. This is not a toy! Operator should have a certain experience, beginners should operate under the guidance of professional players.
2. Before install, please read through the instructions carefully and operate strictly under instructions.
3. Cause of wrong operation, Freewing and its vendors will not be held responsible for any losses.
4. Model planes' players must be on the age of 14 years old.
5. This plane used the EPO material with surface spray paint, don't use chemical to clean, otherwise it will damage.
6. You should be careful to avoid flying in areas such as public places, high-voltage-intensive areas, near the highway, near the airport or any other place where laws and regulation clearly prohibit.
7. You cannot fly in bad weather conditions such as thunderstorms, snows...
8. Model plane's battery, don't allowed to put in everywhere. Storage must ensure that there is no inflammable and explosive materials in the round of 2M range.
9. Damaged or scrap battery should be properly recycled, it can't discard to avoid spontaneous combustion and fire.
10. In flying field, the waste after flying should be properly handled, it can't be abandoned or burned.
11. In any case, you must ensure that the throttle is in the low position and transmitter switch on, then it can connect the lipo-battery in aircraft.
12. Do not try to take planes by hand when flying or slow landing process. You must wait for landing stop, then carry it.

Catalog

Introduction	1	Center of gravity	6
Product basic information	2	Control direction test	7
Package list	2	Dual Rates and Flight setting	8
PNP Install Instructions		Accessories Description	
Install Main wing	3	Servos Introductions	9
Install Horizontal tail	3	Motor Specification	9
Install Vertical tail	4	Install pushrod	10
Install nose cone	4	Install nose landing gear	11
Pushrod instructions	4	Install rear landing gear	12
Control board connection diagram	5	Install Wing-knife	12
Battery size	6		

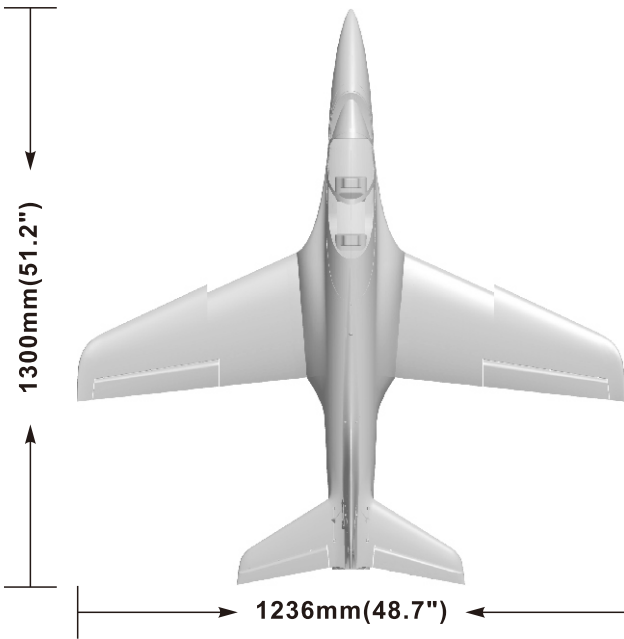

Standard version

Wing loading: 93.5g/dm²
 Motor: 3658-2150KV I/R Motor
 Ducted fan: 80mm 12-blade fan
 ESC: 100A with 7A UBEC
 Servo: 9g digital metal gear servo (8pcs)
 Weight: 1920g(w/o Battery)
 Thrust: 3550g

Other features

- Retract landing gear controlled by electric worm
- New aluminum shock absorber landing gear
- Front, rear landing gear cabin door
- LED light

⚠ Note: The parameters in here are derived from test result using our accessories. If use other accessories, the test result will be different. Any problem since of using other accessories, we are not able to provide technical support.

Package list

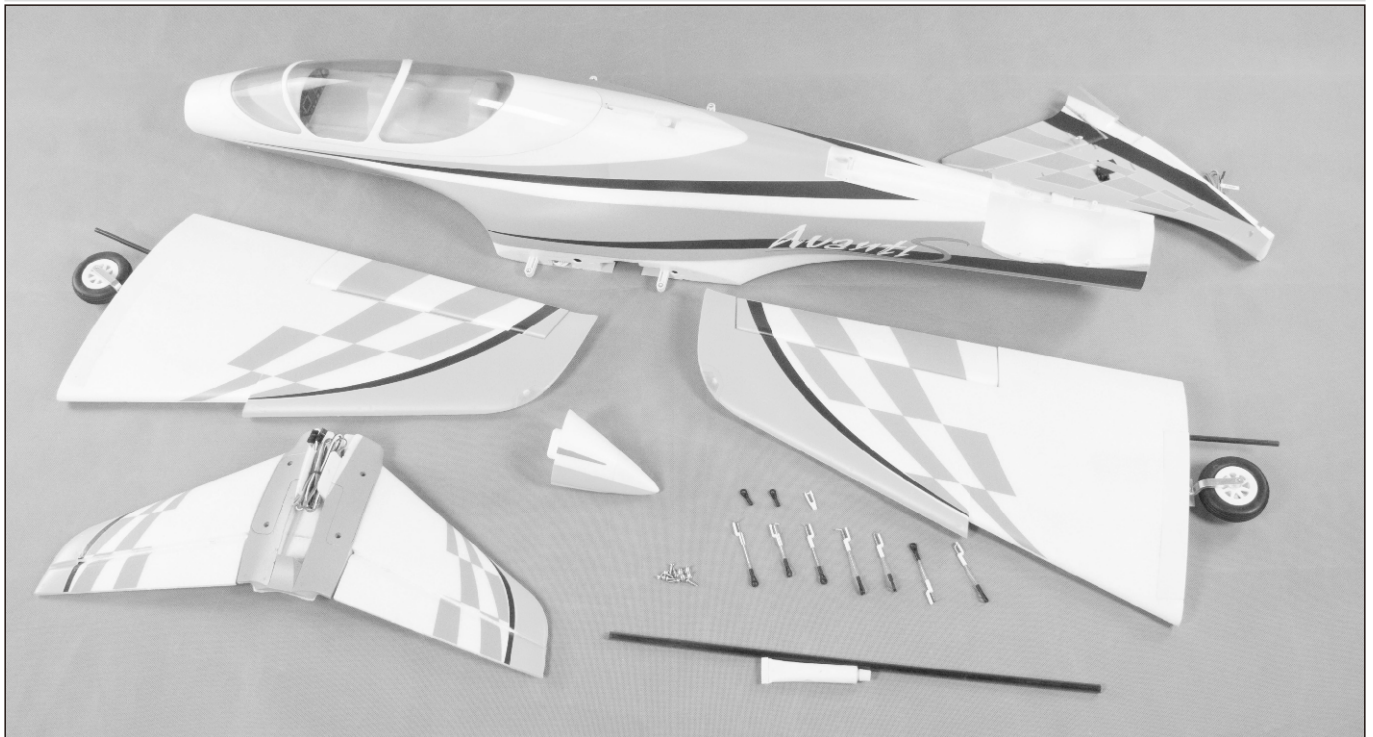

Different equipment include different spareparts. Please refer to the following contents to check your sparepart list.

No.	Name	PNP	ARF Plus	Airframe
1	Fuselage	Pre-installed all electronic parts	Pre-installed servo	No electronic equipment
2	Main wing	Pre-installed all electronic parts	Pre-installed servo	No electronic equipment
3	Horizontal tail	Pre-installed all electronic parts	Pre-installed servo	No electronic equipment
4	Vertical tail	Pre-installed all electronic parts	Pre-installed servo	No electronic equipment
5	Nose cone	✓	✓	✓

No.	Name	PNP	ARF Plus	Airframe
6	Linkage Set	✓	✓	✓
7	Carbon tueb	✓	✓	✓
8	Glue	✓	✓	✓
9	User manual	✓	✓	✓
10	Screw	✓	✓	✓

Install Main wing

Step 1

Carbon tube (Ø8x450mm)

Ribbon wire

main wing trough port

control board

Carbon tube B (Ø6x280mm)

Step 2

Carbon tube A (Ø6x280mm)

Screw (PWM3x6 4pcs)

Step 3

As the picture shown ,

1. Install the carbon tube on the fuselage. ;
2. Insert the Ribbon wire to the Main wing control board, then insert the left/right wing to the fuselage.
3. Use 4 screws to fix the main wing.

Install Horizontal tail

As the picture shown ,

1. Through the fuselage, put the two pcs servo cables in the battery compartment, insert it on the elevator pin of control board.
2. Install the horizontal Stabilizer on the rear of fuselage ;
3. Put the servo cable to the trough, use 4pcs screws to fix the horizontal Stabilizer.

A- Screw (KA3x10 4pcs)

B- Horizontal tail

C- Servo cable

Install Vertical tail

1. As the picture shown, through the fuselage, put the servo cable in the battery compartment, insert it on the rudder pin of control board.
2. Put the servo cable to the trough,
3. Install the Vertical Stabilizer on the rear of fuselage, use 4pcs screws to fix the Vertical Stabilizer

A- Screw (KA3x10 4pcs)

B- Vertical tail

C- Servo cable

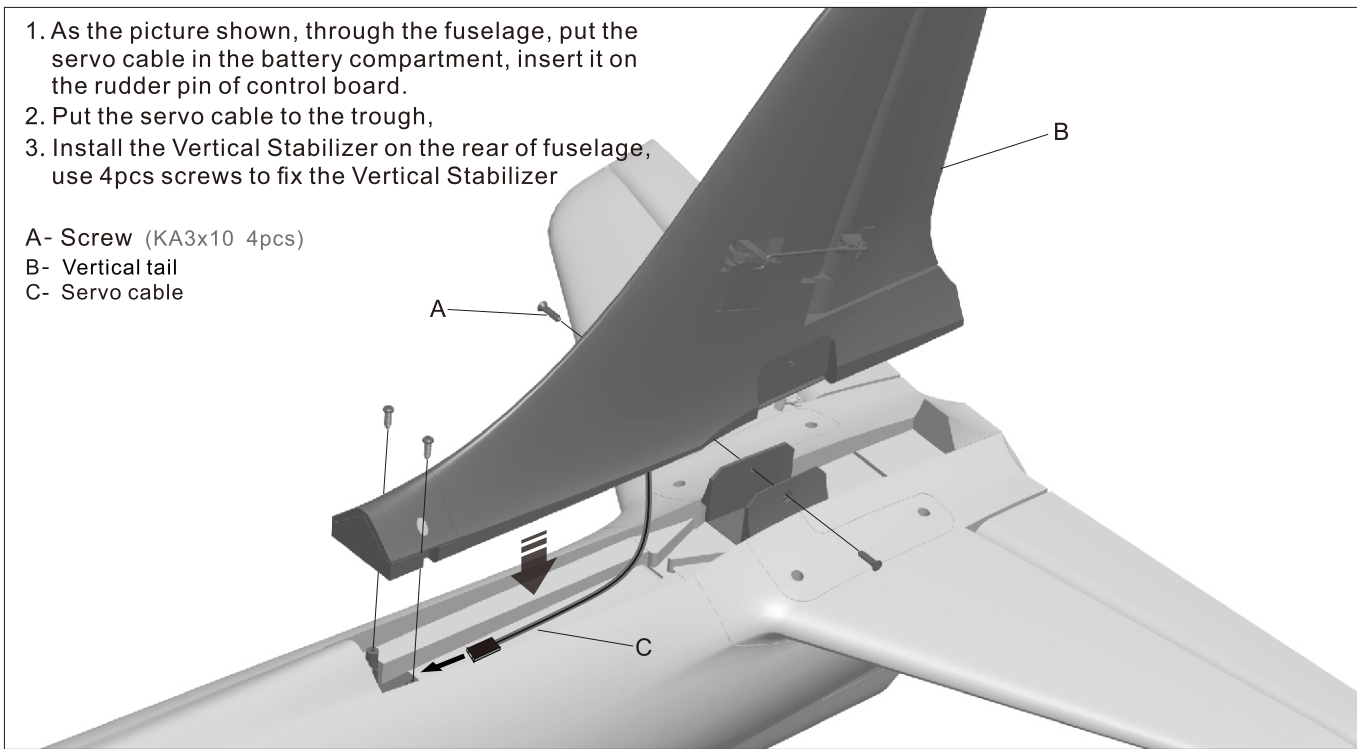

Install nose cone

Since we use the magnet structure, we only need to attach the nose on the nose fuselage.

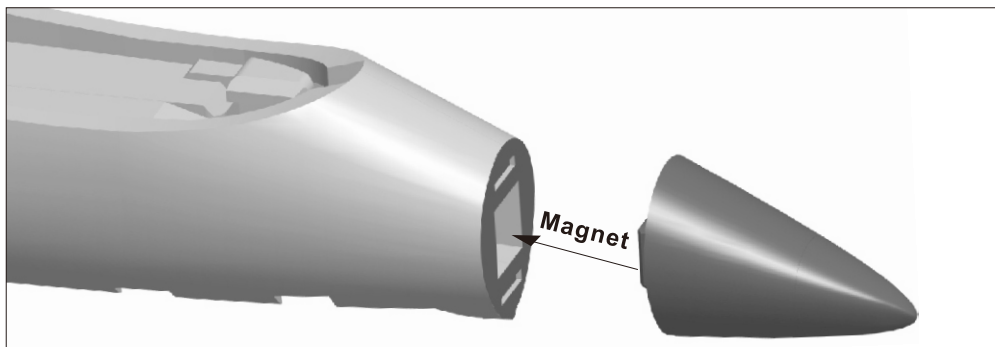

Pushrod instructions

Flap pushrod size

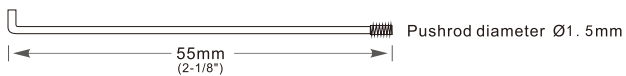

Flap pushrod mounting hole



Aileron pushrod size



Aileron pushrod mounting hole

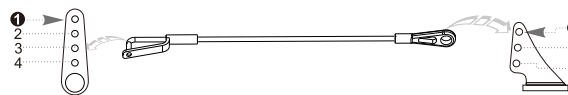

Elevator pushrod size



Elevator pushrod mounting hole

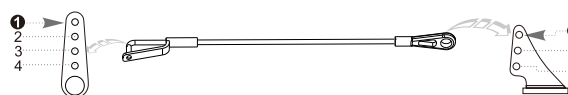

Rudder pushrod size

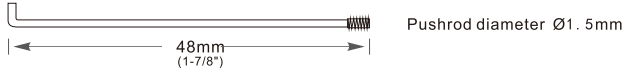

Rudder pushrod mounting hole

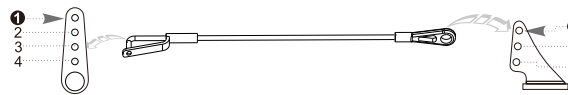

Control board connection diagram

Avantis model plane used the ribbon wire, in order to use more convenient. Please refer to the following photo, connect the electronic equipment.

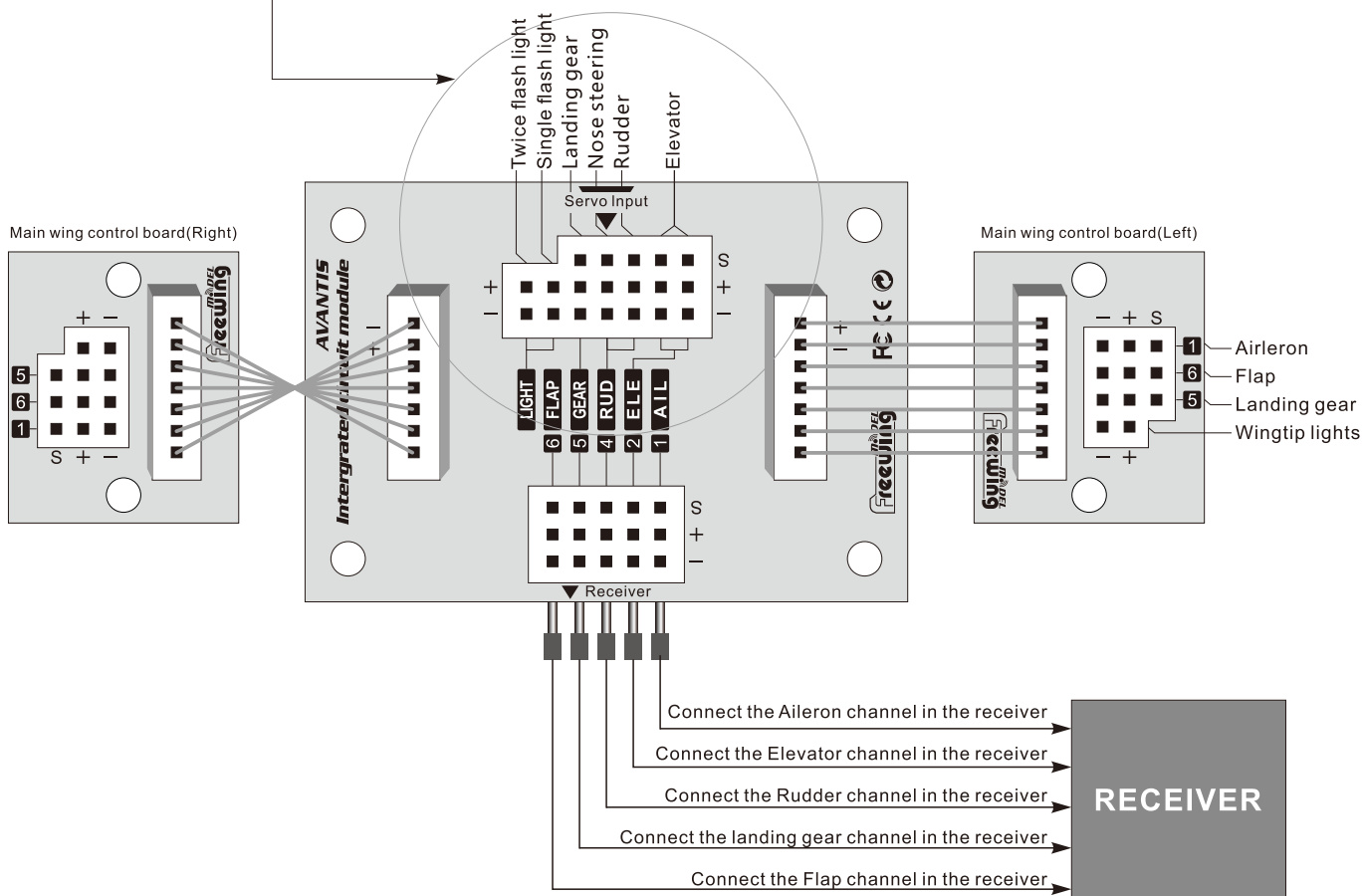
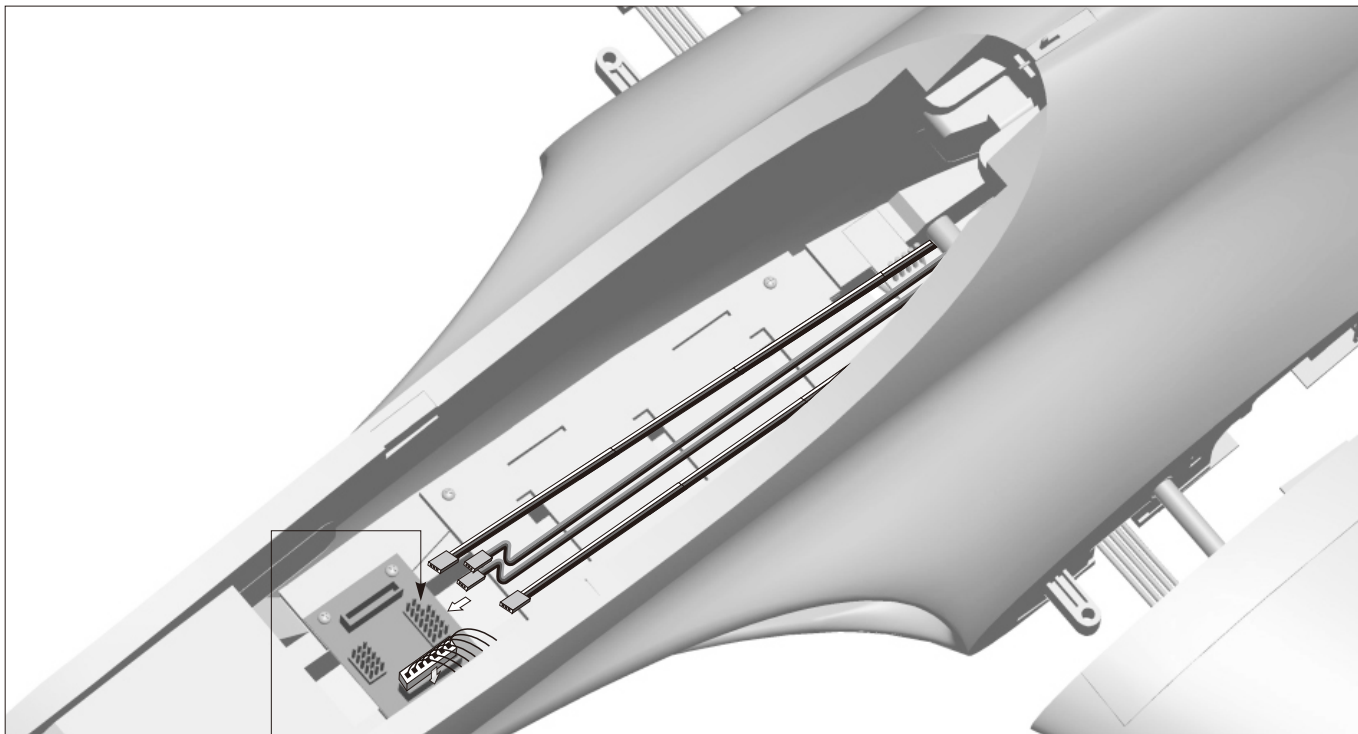

Battery size

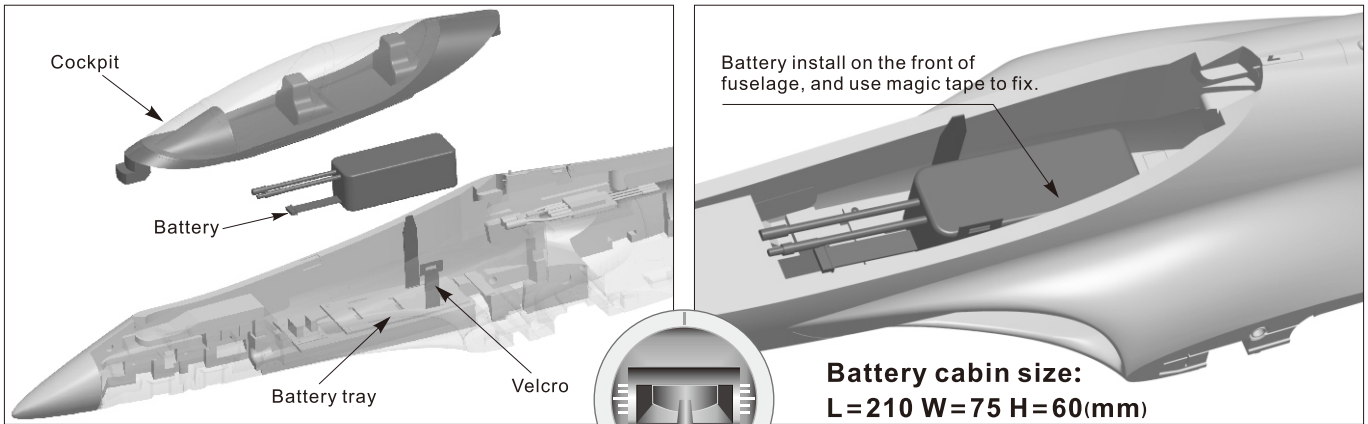

Battery cabin size:
L=210 W=75 H=60(mm)

Before connect the battery and receiver, please switch on the transmitter power and make sure the throttle stick is in the lowest position.

The battery capacity and discharge rate we advise to use are as follows:
6S 22.2V 4000mAh ~ 6S 22.2V 5200mAh
Discharge rate of C ≥ 35C

Center of gravity

Correct center of gravity is directly related to the success of the flight, please refer to the following CG diagram to adjust your plane's center of gravity.

- You can move the battery forward or backward to adjust the center of gravity.
- If you can not adjust the CG through move the battery, you can also use some other suitable material weight to counterweight, to make sure that CG is in the correct position.

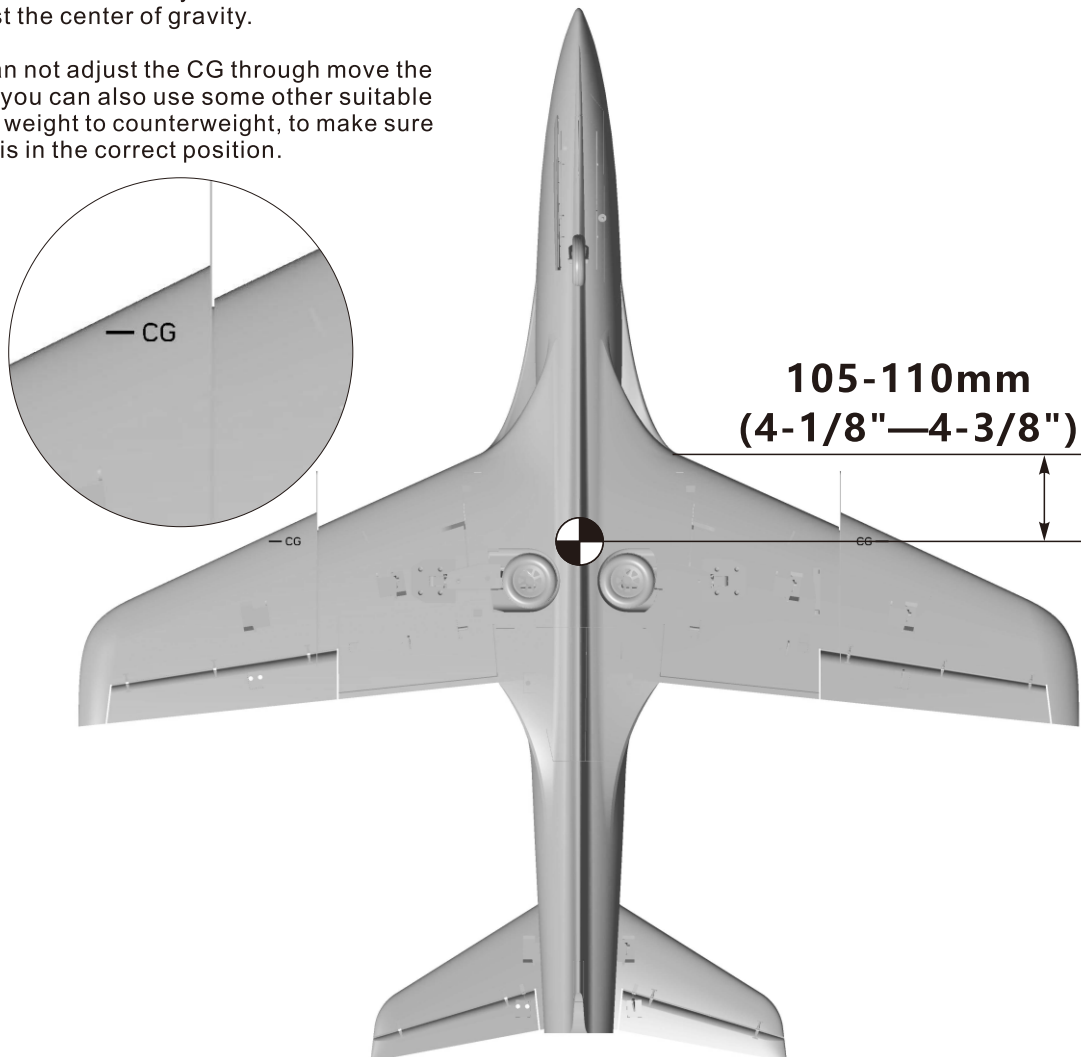

Control direction test

After installed the plane, before flying, we need a fully charged battery and connect to the ESC, then use radio to test and check that every control surface work properly.

Aileron

Stick Left

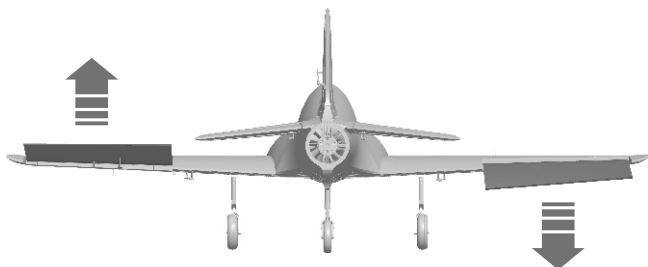

Stick Right

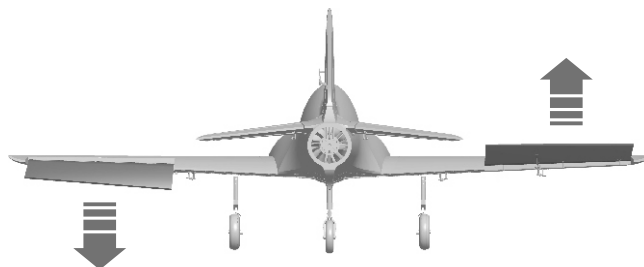

Elevator

Up Elevator

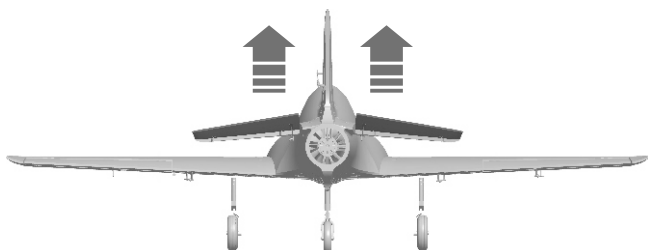

Down Elevator

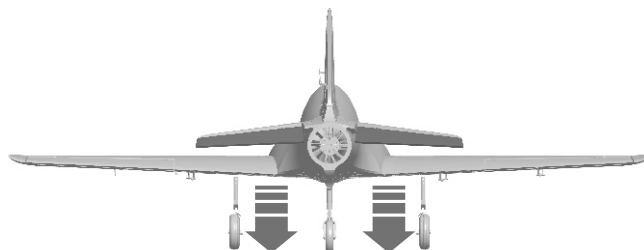

Rudder

Stick Left



Stick Right

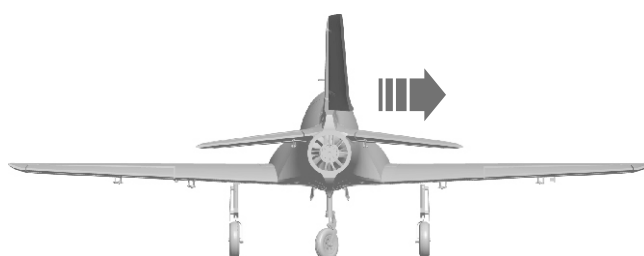

Optional Flaps

Flaps down

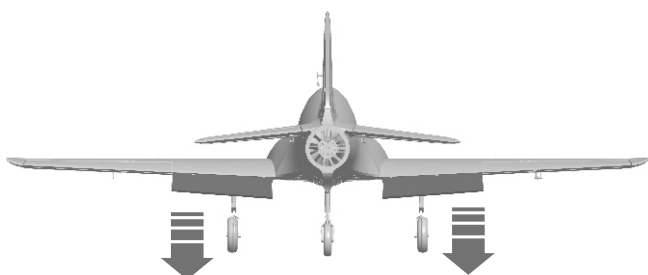

Dual Rates and Flight setting

According to our testing experience, use the following parameters to set aileron/elevator rate, it will be useful for flight. In low rate, it will operate more stable. In high rate, it will operate more sensitive. We advise to use high rate in your first flight, then according to your habit to choose low/high rate.

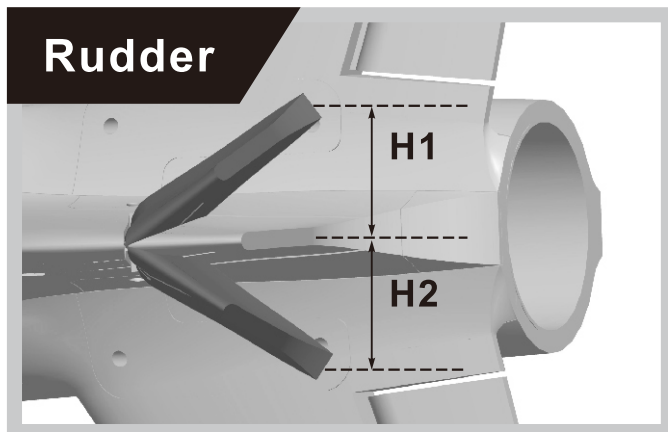
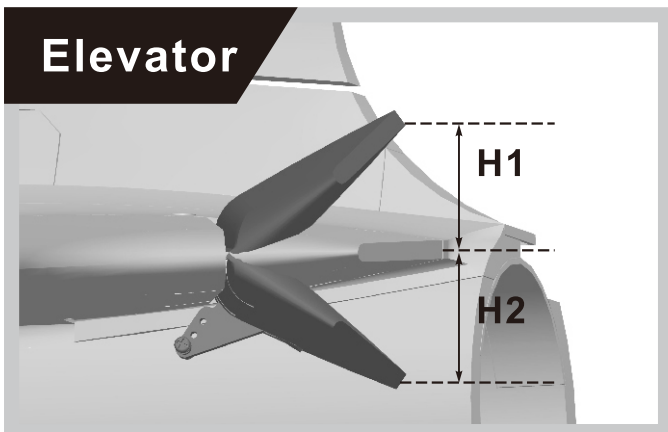
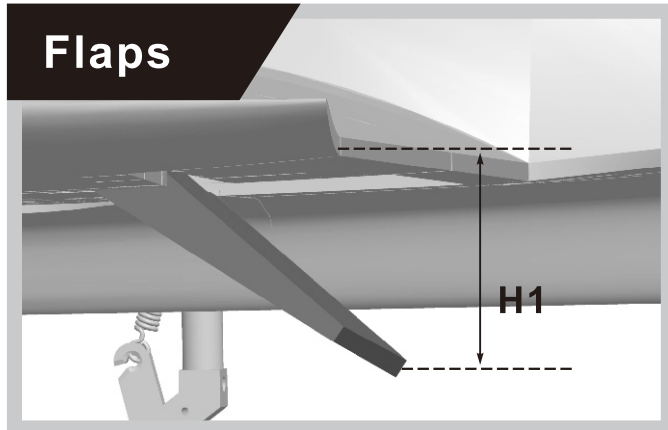
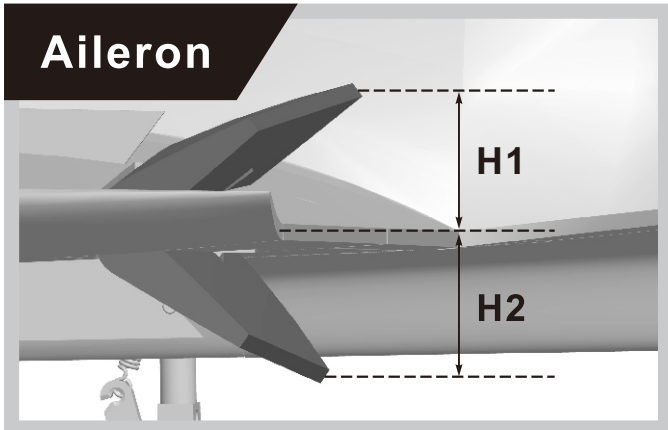

	Aileron	Elevator	Rudder	Flaps
Low Rate	H1/H2 19mm/19mm D/R Rate: 70%	H1/H2 22mm/22mm D/R Rate: 85%	H1/H2 39mm/39mm D/R Rate: 85%	H1 23mm
High Rate	H1/H2 26mm/26mm D/R Rate: 100%	H1/H2 25mm/25mm D/R Rate: 100%	H1/H2 46mm/46mm D/R Rate: 100%	H1 55mm

⚠ Flight attention: When flap down, the nose will rise up, it need to mix the elevator to operate a good landing. In low rate, need to flap down 1mm, In high rate, need to flap down 2mm.

Servos Introductions

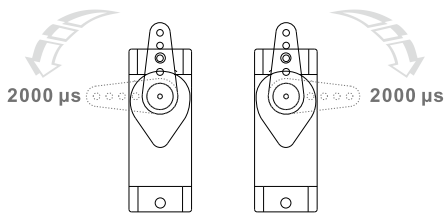

The servo positive or reverse rotation is defined as follows:
 When servo input signal change from 1000 μ s to 2000 μ s,
 The servo arm is **rotated clockwise**, its **positive servo**.
 The servo arm is **rotated counterclockwise**, its **reverse servo**.

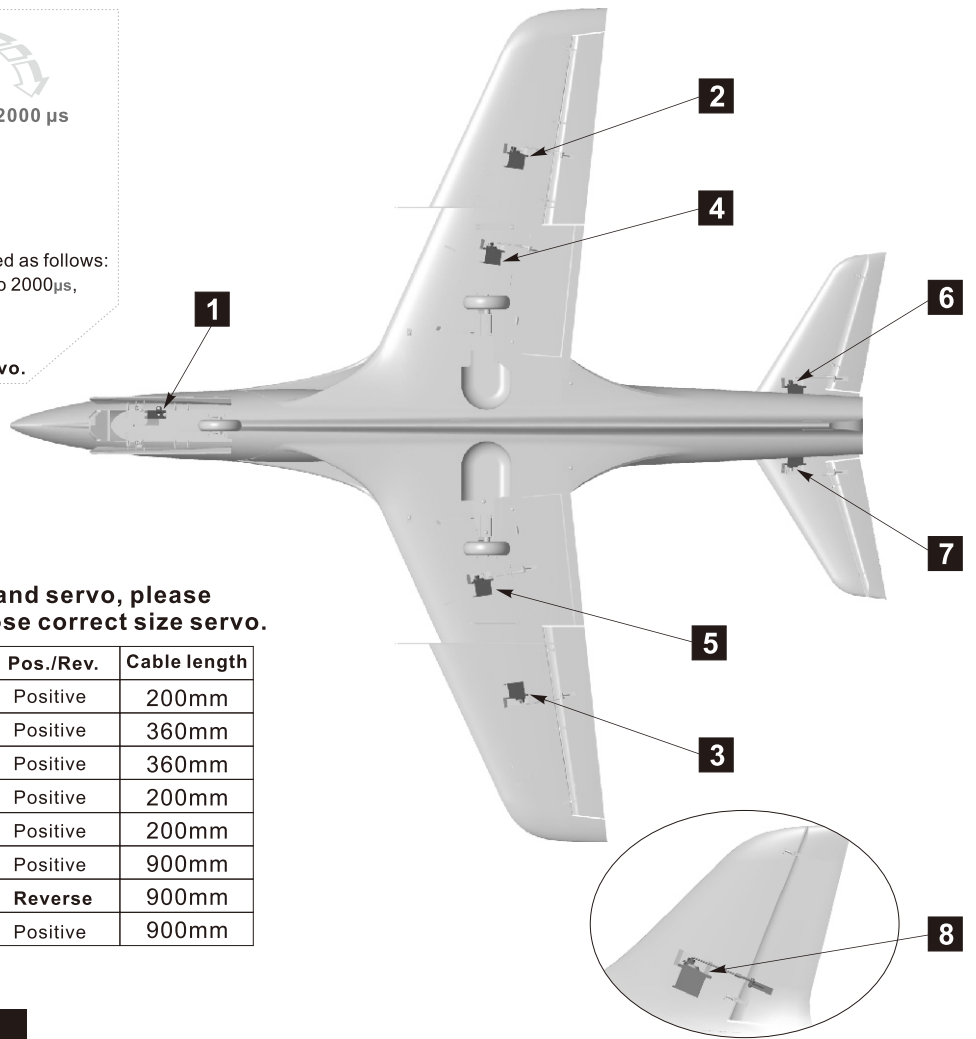

If you need to purchase other brand servo, please refer to the following list to choose correct size servo.

Servo position	Model	No.	Pos./Rev.	Cable length
Nose gear steering servo	9g Digital MG	1	Positive	200mm
Aileron(Left)	9g Digital MG	2	Positive	360mm
Aileron(Right)	9g Digital MG	3	Positive	360mm
Flap(Left)	9g Digital MG	4	Positive	200mm
Flap(Right)	9g Digital MG	5	Positive	200mm
Elevator(Left)	9g Digital MG	6	Positive	900mm
Elevator(Right)	9g Digital MG	7	Reverse	900mm
Rudder	9g Digital MG	8	Positive	900mm

Motor Specification

#MOI36585
 3658-2150KV

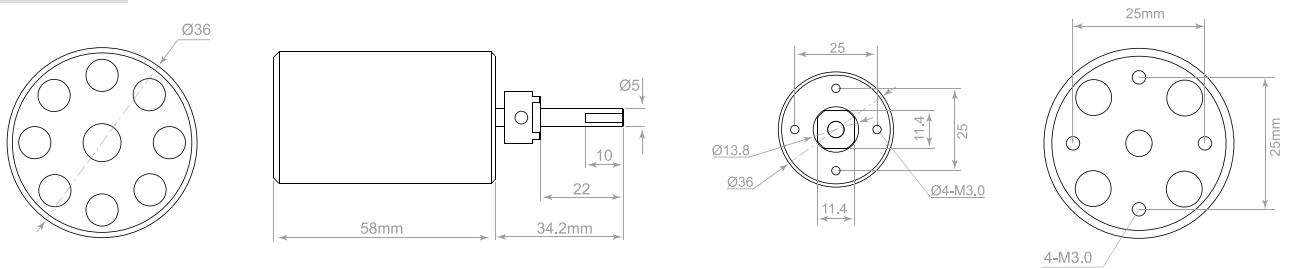

Unit: mm

Item No.	Fan size	Motor specifications	Voltage (V)	Current (A)	Max power (W)	Thrust (g)	Efficiency (g/w)	Speed (rpm)	Weight (g)
E72314	80mm 12-Blade	3658-2150KV	22.2	95	2100	3550	1.7	47700	340

Install Aileron pushrod

1. Use servo tester or radio to center the servo.
2. Use glue to install the servo and aileron horn on the main wing.
3. Buckle the servo cable to the through, after installed all the servos, stick on the decal.
4. One side pushrod insert to the servo arm, adjust its length. And insert the clevis to the aileron horn.
5. Repeat the above four steps, install the other side main wing servo and flap servo.

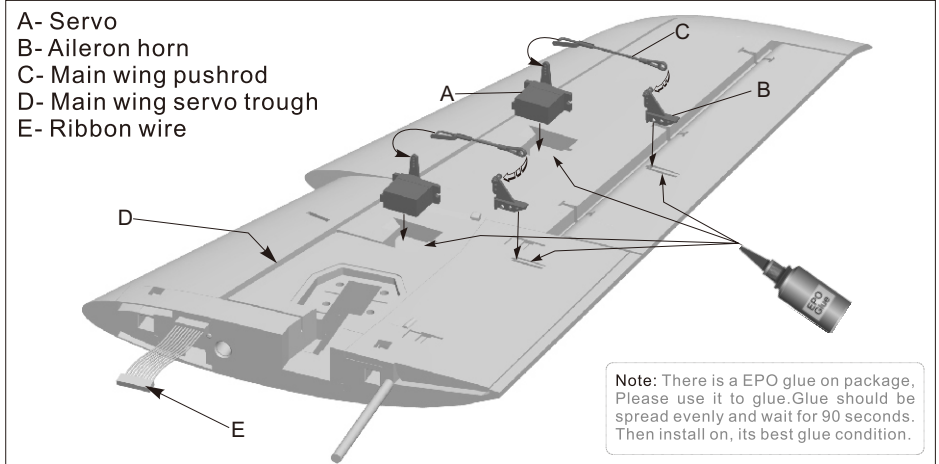

Install Elevator pushrod

1. Use servo tester or radio to center the servo.
2. Use glue to install the servo and aileron horn on the Horizontal tail.
3. Buckle the servo cable to the through, after installed all the servos, stick on the decal.
4. One side pushrod insert to the servo arm, adjust its length. And insert the clevis to the aileron horn.
5. Repeat the above four steps, install the other side Horizontal tail servo.

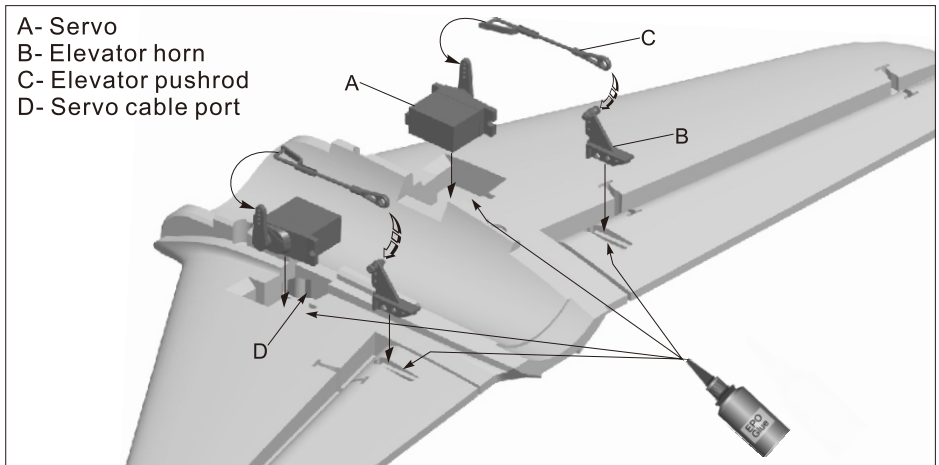

Install Rudder pushrod

1. Use servo tester or radio to center the servo.
2. Use glue to install the servo and aileron horn on the Vertical tail.
3. Buckle the servo cable to the through, after installed all the servos, stick on the decal.
4. One side pushrod insert to the servo arm, adjust its length. And insert the clevis to the aileron horn.

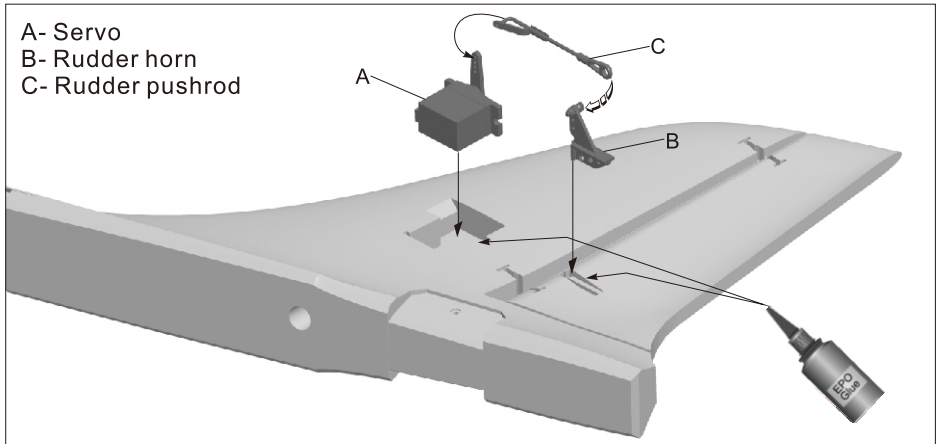

Important additional notes

The Y-type clevis used in this product is equipped with a transparent silicone ring for secondary reinforcement, which can effectively prevent the clevis from accidentally loosening.

As shown in the following figure, when you buckle the clevis into the control surface horn, use the silicone ring to cover the clevis.

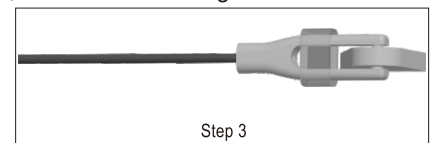
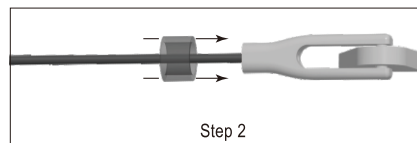
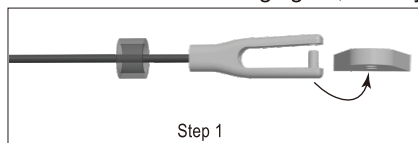

Install nose landing gear

Please assemble, disassemble the nose landing gear according to the following photo.

Accessories name and specification

- | | | |
|----------------------------------|--------------------------|------------------------------------|
| A - E-buckle (M3) | L - Pin (Ø3.5x9.2mm) | W - Rotating arm |
| B - Nose wheel (Ø65x16mm) | M - E-buckle (M1.5) | Z - Nose metal wire |
| C - Nose gear axle | N - Screw (PM2x3 1pcs) | AB - Screw (PA1.4x12 2pcs) |
| D - U-shape slant supporting rod | O - Nose gear strut | AC - Screw (PA1.7x10 4pcs) |
| E - Pin (Ø3.5x10.2mm) | P - Pin (Ø3.5x10.2mm) | AD - Screw (FA3x12 4pcs) |
| F - E-buckle (M1.5) | Q - E-buckle (M1.5) | AE - Retract Reinforcement Plate |
| G - Nose gear steering ring | R - JIMI Screw (M4x3mm) | AF - Nose landing gear |
| H - Spring | S - L-shape rotating arm | AG - Nose steering pushrod |
| I - 8-shape connecting arm | T - JIMI Screw (M3x3mm) | AH - Screw (PWA2.3x8 2pcs) |
| J - Nose strut fixed ring | U - O-shape ring | AI - Servo |
| K - Screw (PM2x3 1pcs) | V - Pushrod | AJ - Nose landing gear door type A |
| | | AK - Cabin door spring |
| | | AL - Screw (PA2x8 4pcs) |
| | | AM - Spring |

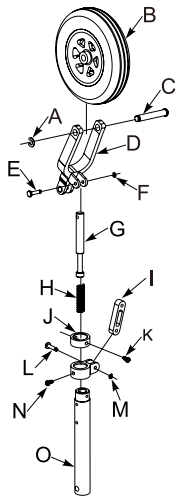

Step 1

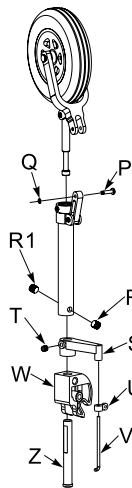

Step 2

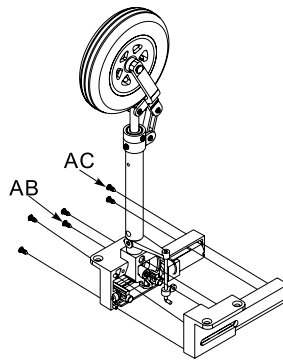

Step 3

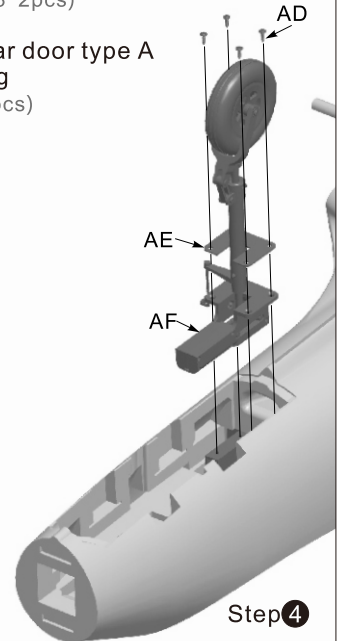

Step 4

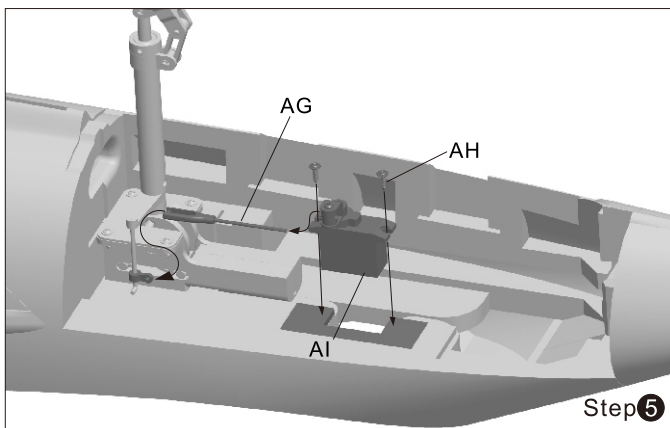

Step 5

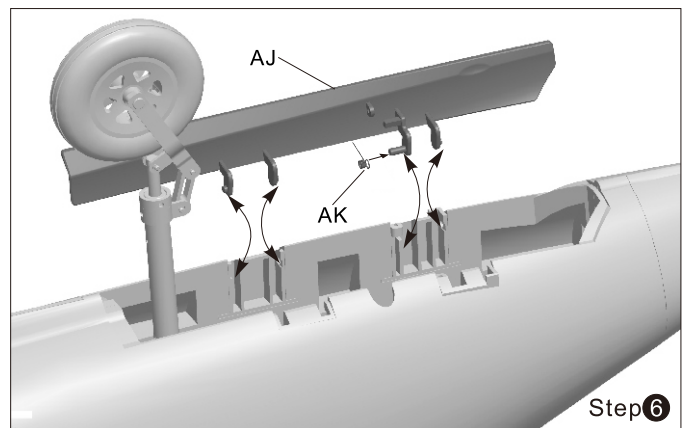

Step 6

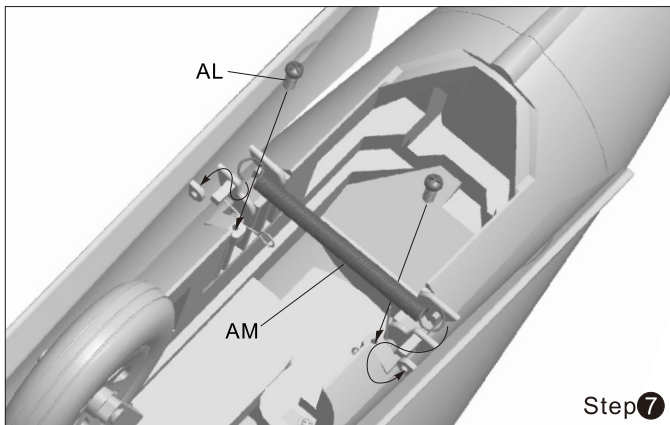

Step 7

Nose steering pushrod size

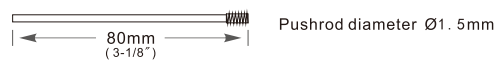

Servo pushrod installing hole



⚠ Note : When installing, please check the flat position of spareparts, when screw to fix, the flat position must face to the screw hole, just like this, it can fix successfully, the spareparts don't rotate and fall off.

Install rear landing gear

Please assemble, disassemble the rear landing gear according to the following photo.

Accessories name and specification

- A - Main gear axle
- B - Main wheel (Ø70x20mm)
- C - JIMI Screw (M4x4mm 1pcs)
- D - Rear gear slant supporting rod
- E - Main gear strut A
- F - JIMI Screw (M4x3mm 2pcs)
- G - Main gear strut B
- H - Spring
- I - Screw (PM3x4mm 1pcs)
- J - JIMI Screw (M4x3mm 2pcs)
- K - Main gear main rod
- L - Retract controller
- M - JIMI Screw (M4x3mm 2pcs)
- N - Screw (PM2x5mm 2pcs)
- O - Nose gear cabin door
- P - Screw (FA3x12mm 4pcs)
- Q - Main landing gear set
- R - Main landing gear mount

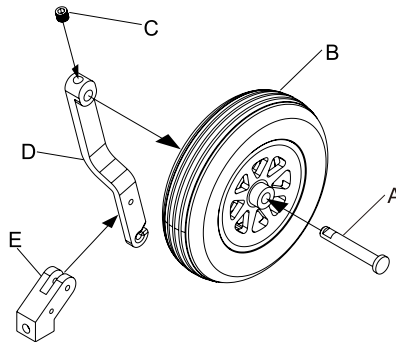

Step 1

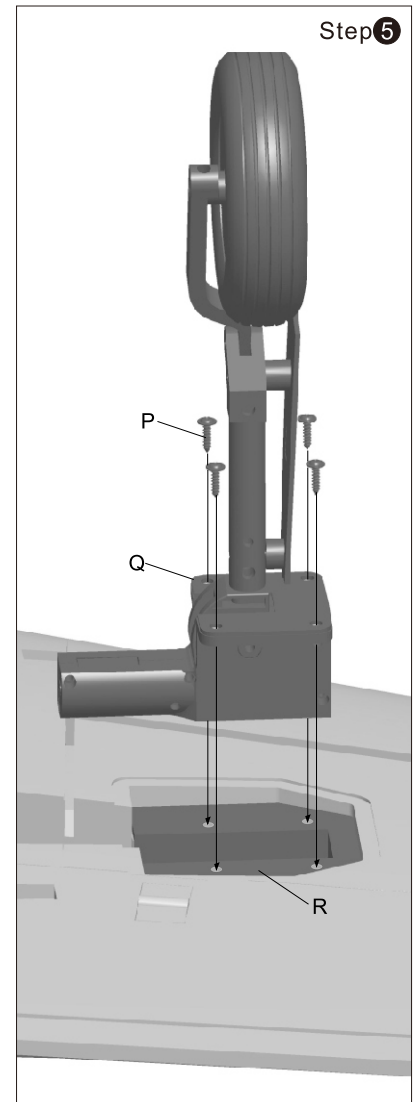

Step 5

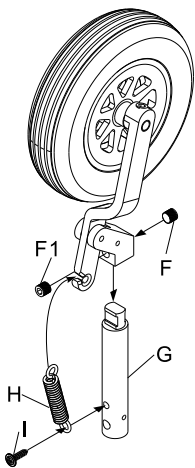

Step 2

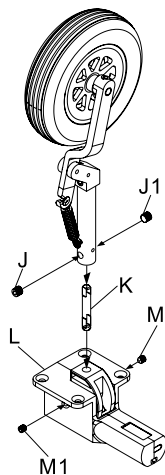

Step 3

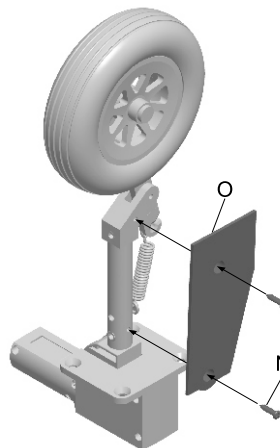

Step 4

Install Wing-knife

As the photo shown :
Use a knife to cut the wing-knife groove along the top of main wing, depth 3mm, thickness 2mm, length 153mm, and then touch the glue, insert the wing-knife into the wing-knife groove.

Note: This product we provided the wing-knife spare part, you can install by yourself. Installed the wing-knife, its lateral stability is better to do some aerobatic manoeuvre, flight is more stable.

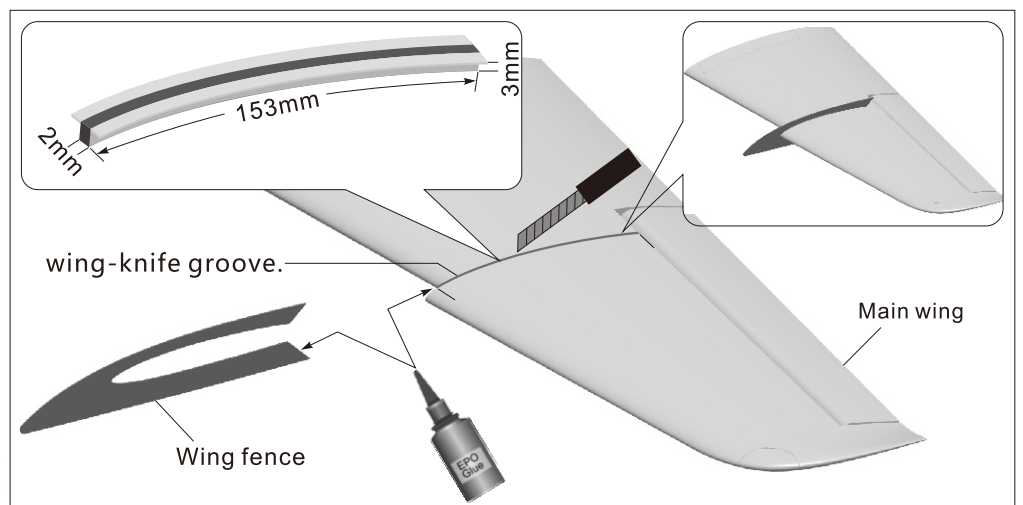

非常高兴您选择飞翼模型80系列涵道运动机阿凡提，这款产品的原型源自于著名的意大利F3A世界级冠军选手Sebart设计的一款玻璃钢涡喷运动机。我们在得到Sebart的授权许可和协助下，重新将此模型设计成为一款小型化的电动泡沫运动机，让更多的人能够体验到这款优秀产品的独特飞行魅力。新的电动阿凡提，采用EPO泡沫材料，机长1300mm（51.2"），翼展1236mm（48.7"），集线板的使用，拆装简便，易于携带。搭载的全新一体式12叶80mm涵道动力级搭配100A电子调速器，带来充沛的动力。

阿凡提拥有极佳的飞行姿态稳定性，能够轻松驾驭多种F3A特技动作。飞机在降落的低速阶段，能够保持非常平稳的姿态，使操控者可以轻松、轻柔的降落。这款阿凡提电动泡沫模型飞机，不仅适合于热爱特技飞行的爱好者，同样，也是一款性能优异的电动涵道初级教练机。

⚠ 注意：模型产品是具有一定危险性的产品，请禁止14岁以下的儿童玩耍，14岁以上的儿童，请在有飞行经验的成人指导下使用，无飞行经验的购买者，应当在具有一定电动涵道飞机飞行经验的成人指导下使用！组装模型前，请仔细阅读说明书，按照说明书的要求进行安装。进行调试和飞行时，请根据说明书指示的参数进行调整。

重要提示

- 1.模型飞机不是玩具,操作者需要具备一定的经验;没有经验的初学者,必须在有丰富经验的专业人士指引下,逐步学习!
- 2.在组装之前,必须认真阅读产品说明书,严格按照说明书指示操作。
- 3.飞翼模型及其销售商,对于违反说明书的要求操作而造成的损失、将不负任何法律责任!
- 4.模型飞机的使用年龄必须是14岁以上的儿童或者成人。
- 5.此模型产品使用EPO材料制成,表面喷涂油漆,不可随意使用化学制剂擦拭,否则会损坏模型产品。
- 6.不可以在公共场合、高压线密集区、高速公路附近、机场附近或者其他法律法规明确禁止飞行的场合飞行。
- 7.不可以在雷雨、大风、大雪或者其他恶劣气象环境下飞行。
- 8.模型飞机的电池产品,不可以随意乱扔,乱放。存放时,必须保证周边2M范围内,无易燃、易爆物体。
- 9.损坏或者报废处理的模型飞机电池,应妥善回收处理,不准随意抛弃,避免自燃而引发火灾。
- 10.在飞场飞行时,应做到妥善处理飞行后所产生的垃圾,不可随意抛弃、焚毁模型及其配件。
- 11.在任何情况下,都必须保证油门杆处于起始位、发射机处于打开状态时,才能连接模型飞机内部的动力电池。
- 12.无论是模型飞机是在正常飞行过程中,或者是在缓慢降落过程中,都不要尝试用手去回收模型。必须等模型降落平稳以后,再进行回收!

目录

前言	13	重心示意图	18
产品基本参数	14	舵面测试	19
产品包装清单	14	大、小舵参考及飞行设定	20
PNP组装说明		配件说明	
主翼组装	15	舵机使用说明	21
平尾组装	15	电机参数	21
垂尾组装	16	舵面钢丝安装	22
机头罩安装	16	前起落架组装	23
舵面控制钢丝尺寸	16	后起落架组装	24
集线板连接示意图	17	翼刀安装	24
电池安装说明	18		

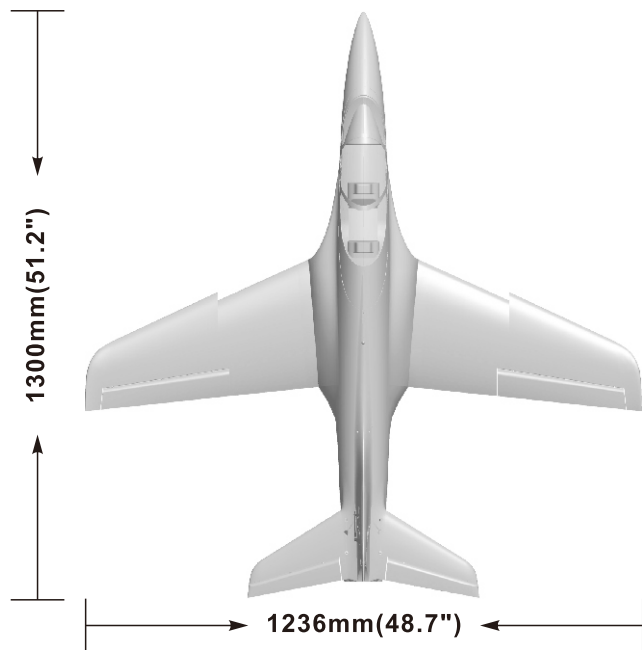

标准版

翼载荷: 93.5g/dm²
 电机: 3658-2150KV内转无刷电机
 涵道风扇: 80mm 12叶一体涵道
 电调: 100A无刷电调 UBEC 7A
 舵机: 9g数字金属舵机 (8pcs)
 重量: 1920g(不含电池)
 推力: 3550g

其它特性

- 电动涡杆收放起落架
- 新型铝合金减震起落架
- 前、后起落架舱门
- LED灯

注意: 此处各项参数, 均使用本公司配件测试得出, 如果使用副厂配件, 会有所差异。使用副厂配件时所产生的问题, 我们将无法给予技术支持!

产品包装清单

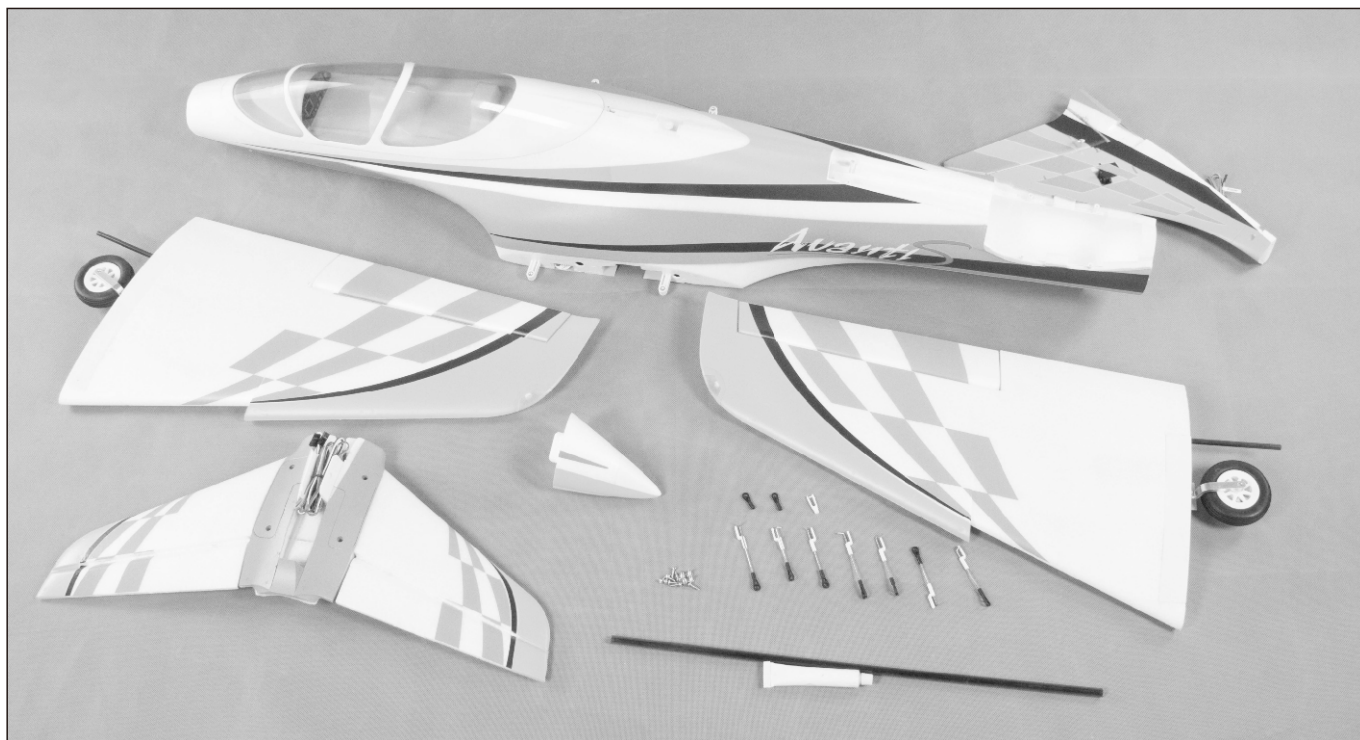

打开产品包装, 核对包装清单。(不同配置的版本, 包含内容不同!)

序号	配件名称	PNP	ARF Plus	Airframe	序号	配件名称	PNP	ARF Plus	Airframe
1	机身	预装所有电子设备	预装舵机	不含电子设备	6	舵面控制钢丝	✓	✓	✓
2	主翼	预装所有电子设备	预装舵机	不含电子设备	7	碳纤维管	✓	✓	✓
3	平尾	预装所有电子设备	预装舵机	不含电子设备	8	胶水	✓	✓	✓
4	垂尾	预装所有电子设备	预装舵机	不含电子设备	9	说明书	✓	✓	✓
5	机头罩	✓	✓	✓	10	螺丝	✓	✓	✓

主翼组装

步骤 1

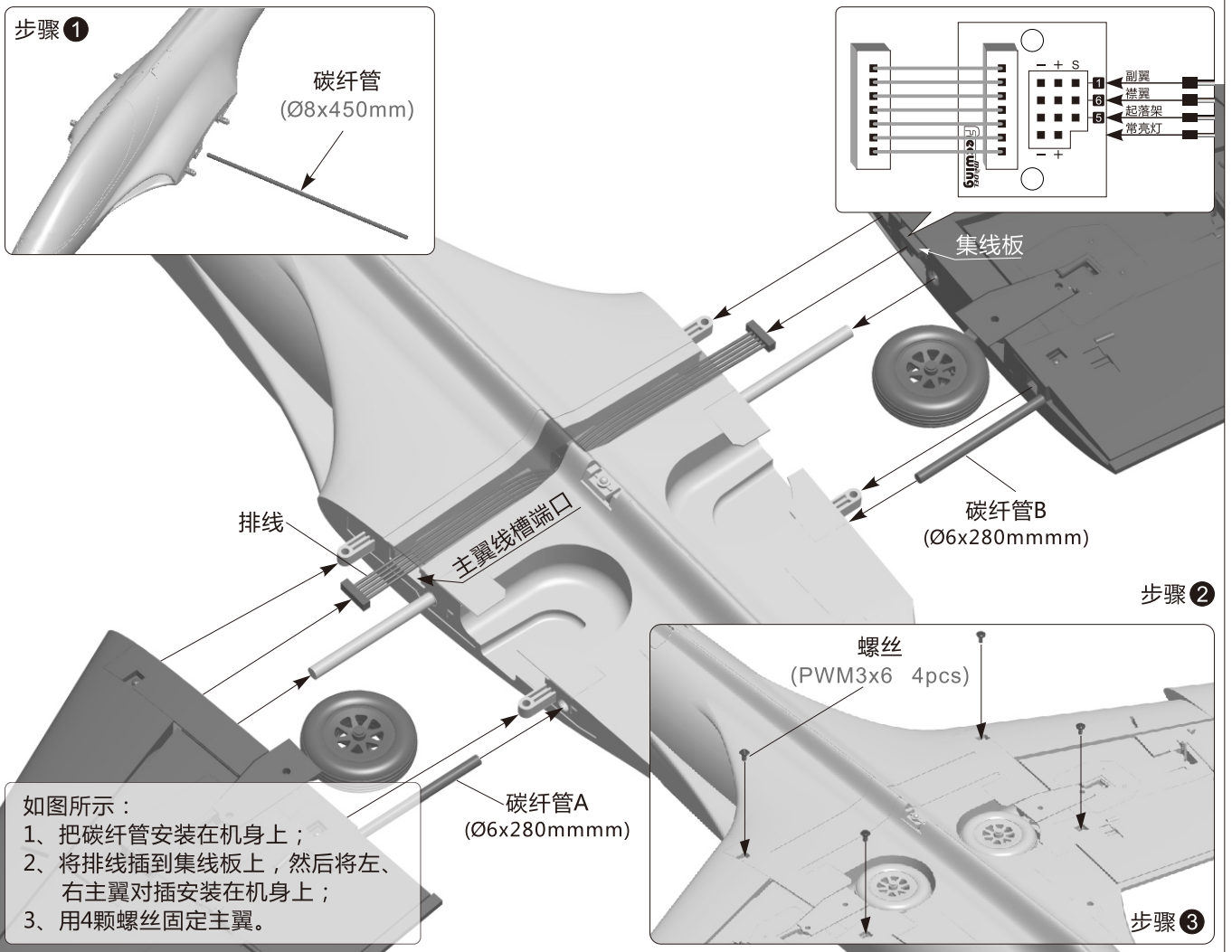

平尾组装

如图所示：

1. 把两条舵机线穿入机身并拉到机身前方的电池舱里面，插在集线板上的升降舵插针上。
2. 将平尾安装在机身尾部上；
3. 把舵机线卡到线槽内，然后用4颗螺丝固定平尾。

- A- 螺丝 (KA3x10 4pcs)
 B- 平尾
 C- 舵机线

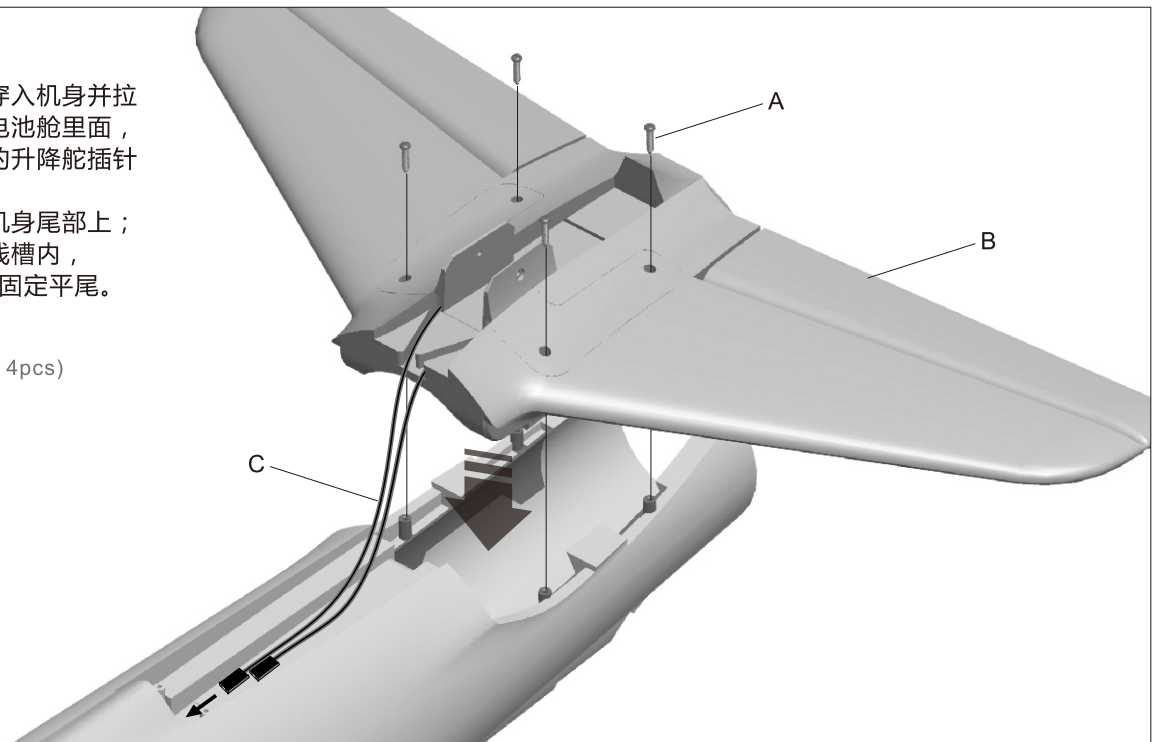

垂尾组装

1. 如图所示，把舵机线穿入机身并拉到机身前方的电池舱里面，然后插在集线板上的方向舵插针上。
2. 把舵机线卡到线槽内；
3. 将平尾安装在机身尾部上，然后用
4. 4颗螺丝固定垂尾。

- A- 螺丝 (KA3x10 4pcs)
- B- 垂尾
- C- 舵机线

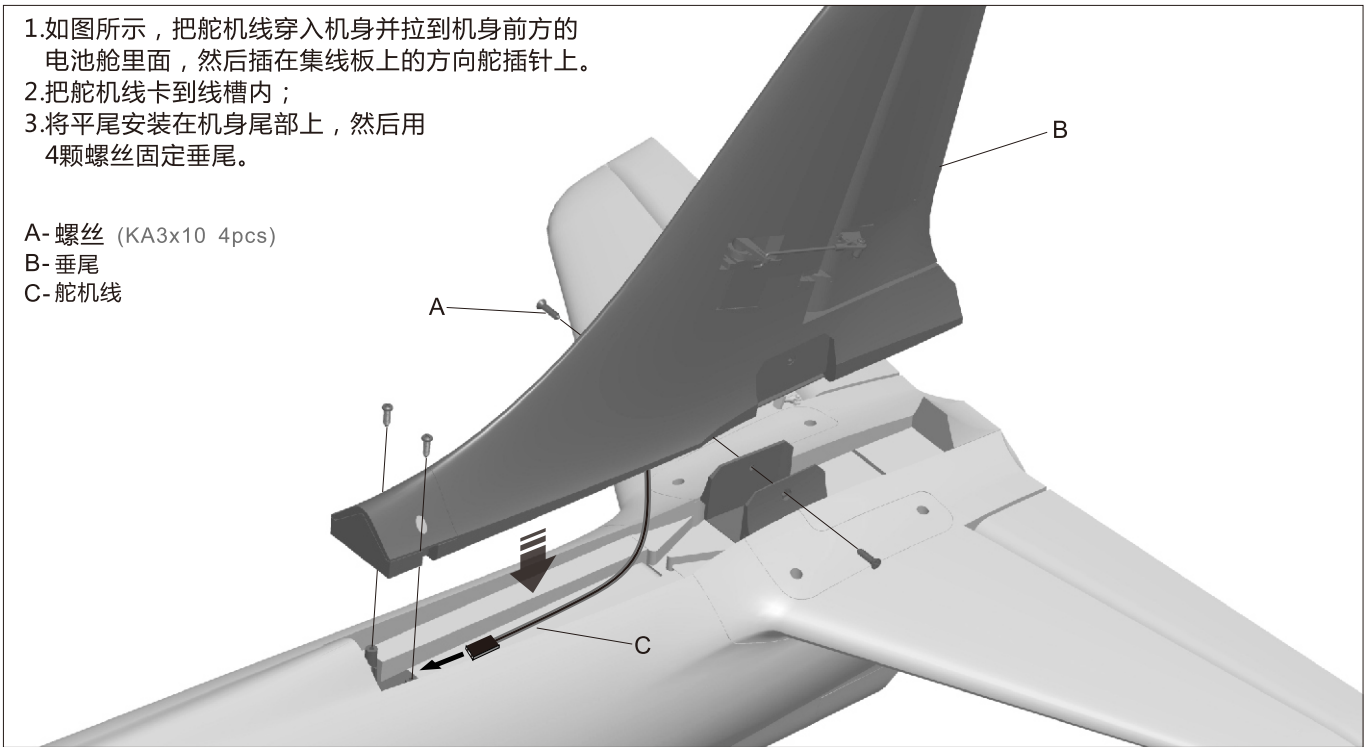

机头罩安装

由于采用磁力吸附结构，我们只需要装机头罩吸在机头前端即可。

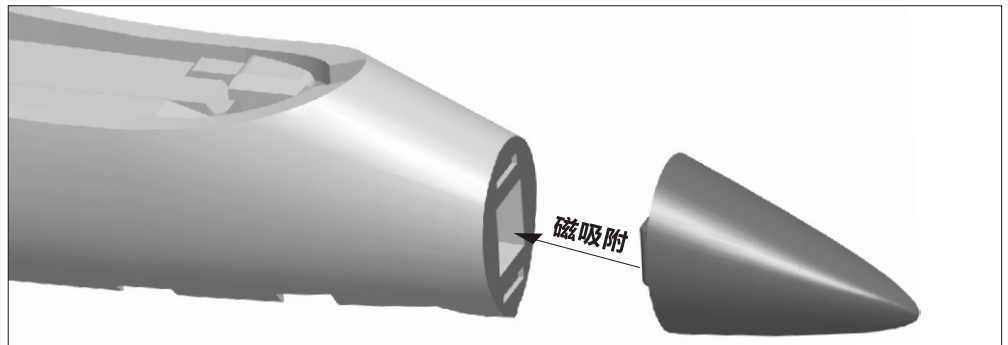

舵面控制钢丝尺寸

襟翼控制钢丝尺寸



襟翼舵机钢丝安装孔位



副翼控制钢丝尺寸



副翼舵机钢丝安装孔位



平尾控制钢丝尺寸

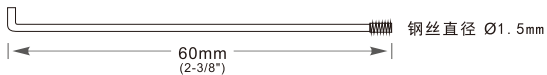

平尾舵机钢丝安装孔位



垂尾控制钢丝尺寸



垂尾舵机钢丝安装孔位



集线板连接示意图

阿凡提模型飞机，使用了集线板，以达到后期便捷使用的目的。请参考下图，连接电子设备。

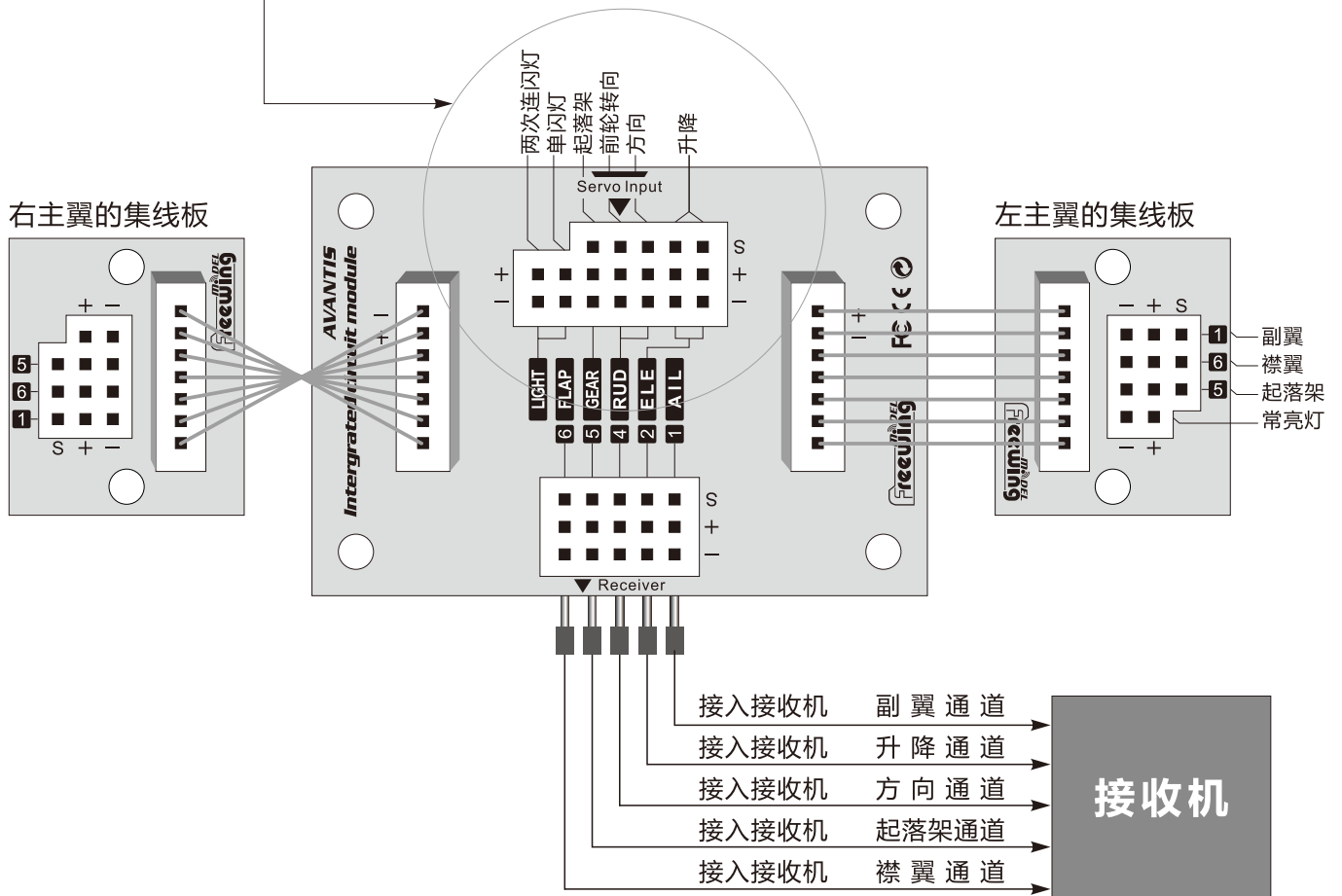
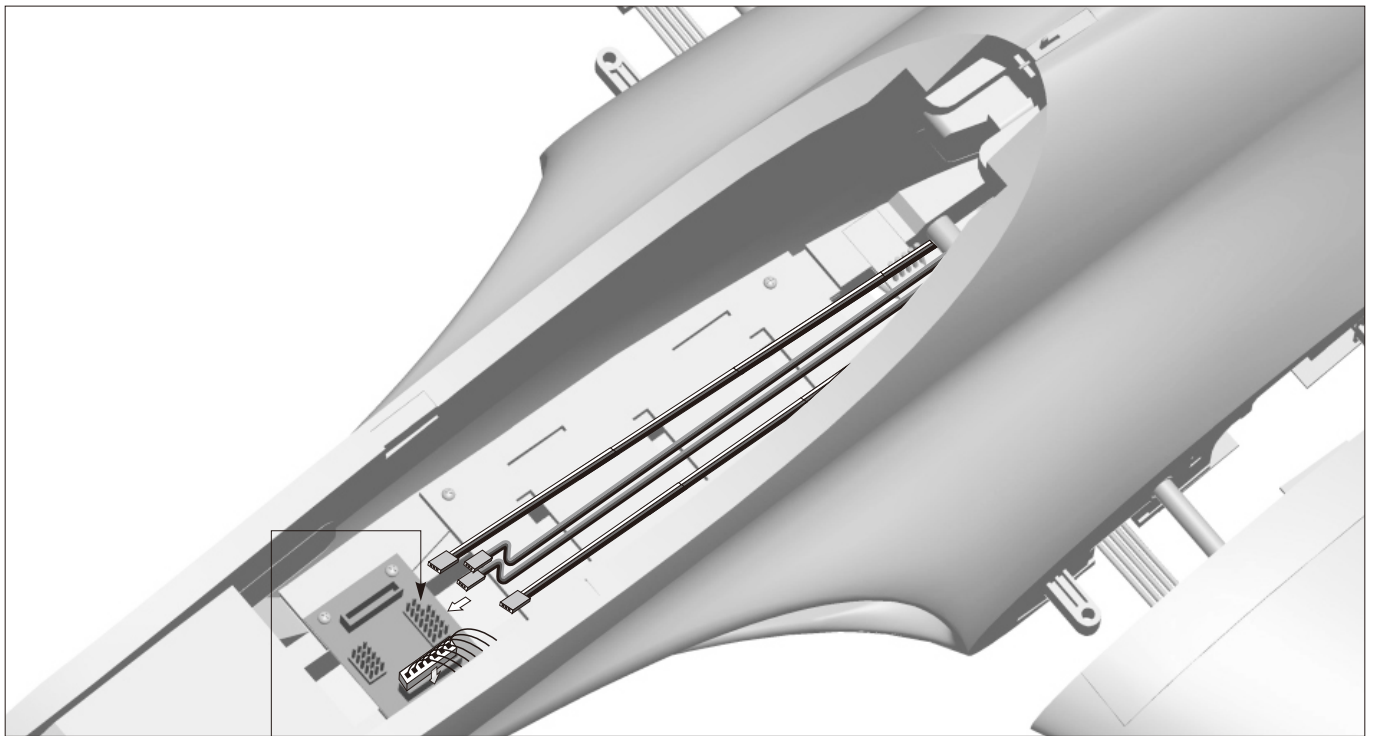

电池安装说明

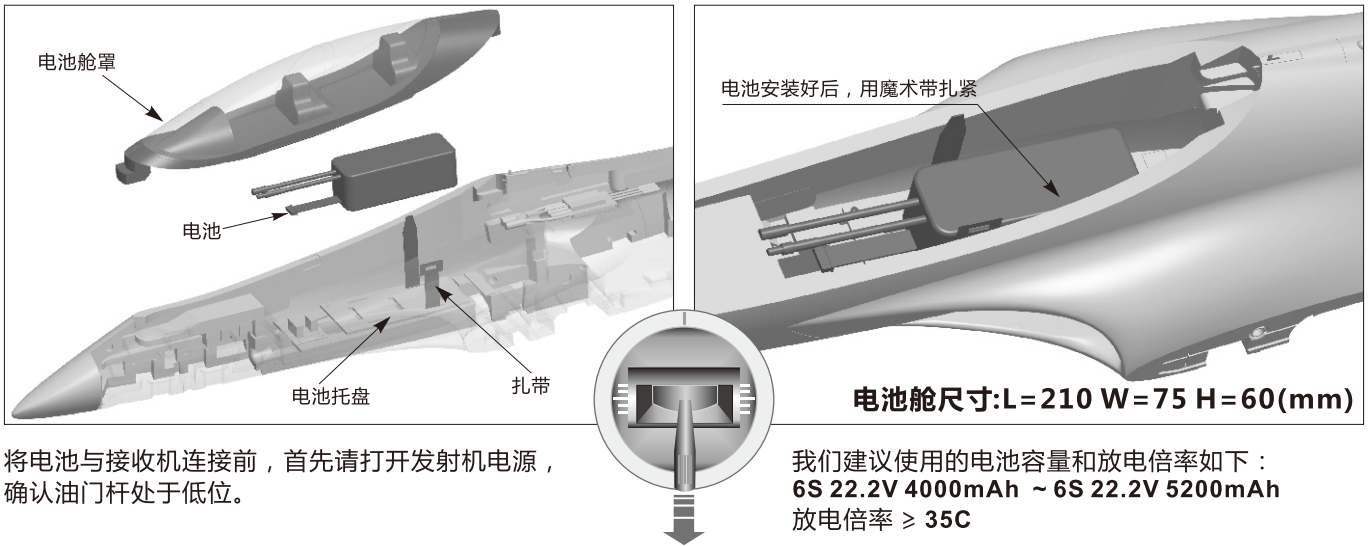

电池舱尺寸:L=210 W=75 H=60(mm)
 我们建议使用的电池容量和放电倍率如下：
6S 22.2V 4000mAh ~ 6S 22.2V 5200mAh
 放电倍率 ≥ 35C

重心示意图

正确的重心，直接关系到飞行的成功与否，请参考下面的重心标示图，来调整飞机的重心。

- 您可以将电池向前，或者向后移动，来调整飞机的重心；
- 如果通过电池的移动无法调整到正确的重心位置，您还可以适当的使用一些其它材料来配重，使飞机的重心处于正确的位置！

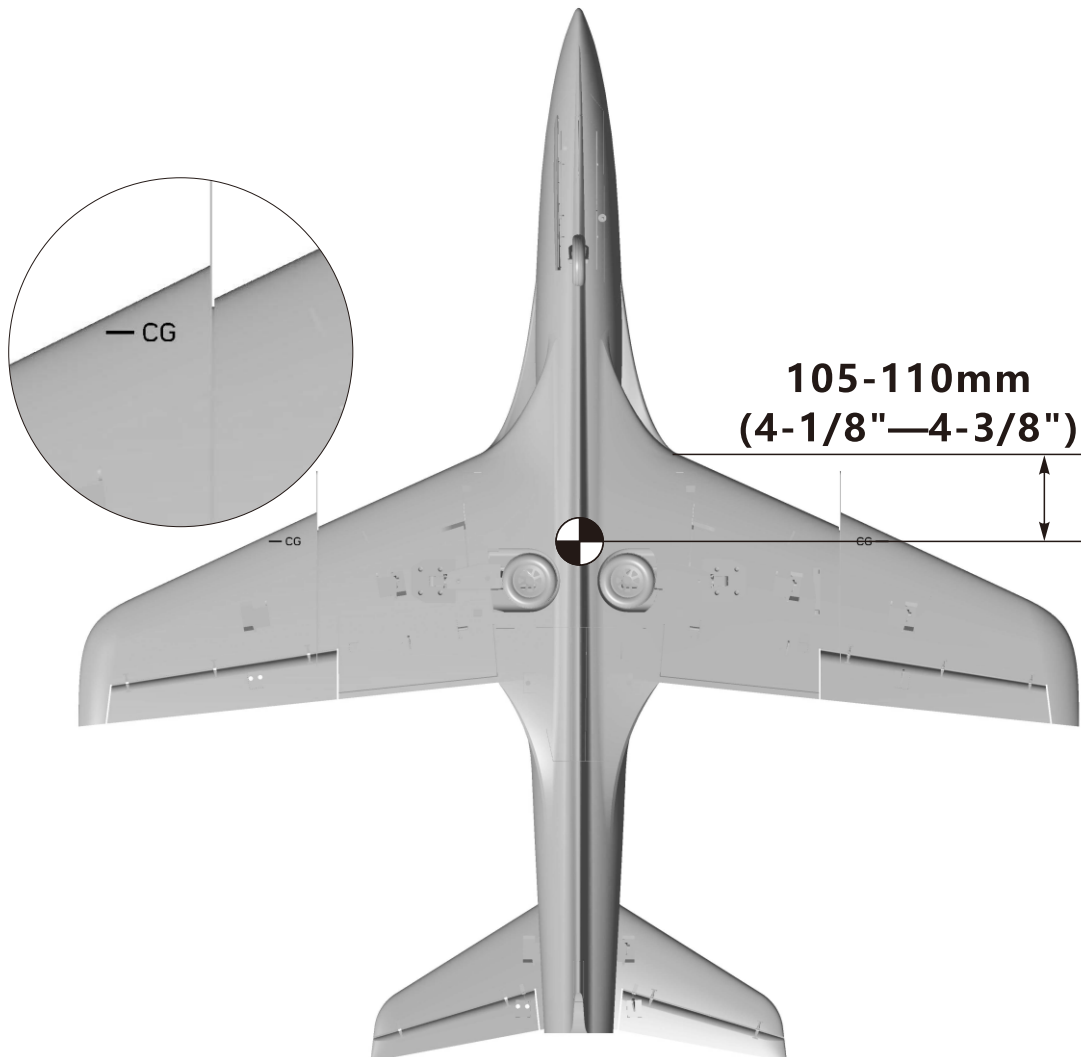

舵面测试

当您按前面的步骤组装好飞机后，在飞行前，我们需要用一块充满电的电池，连接到电调。用遥控器测试每个舵面的工作情况，检查是否正常！

副翼

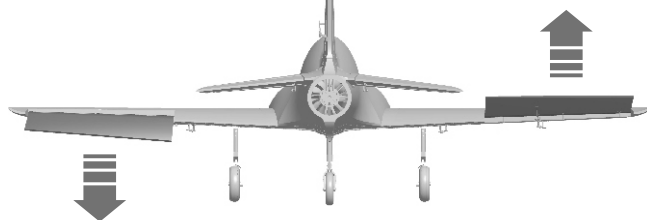
副翼摇杆
向左运动副翼摇杆
向右运动

升降舵

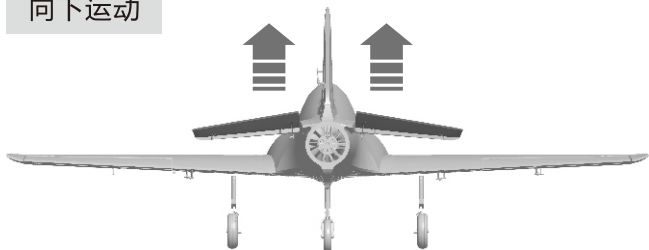
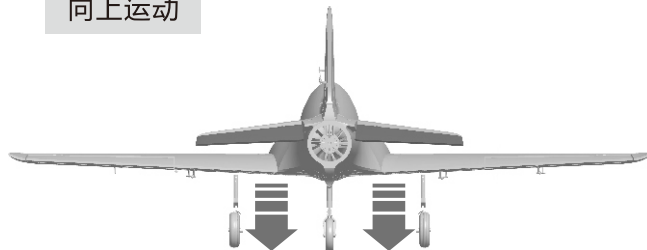
升降摇杆
向下运动升降摇杆
向上运动

方向舵

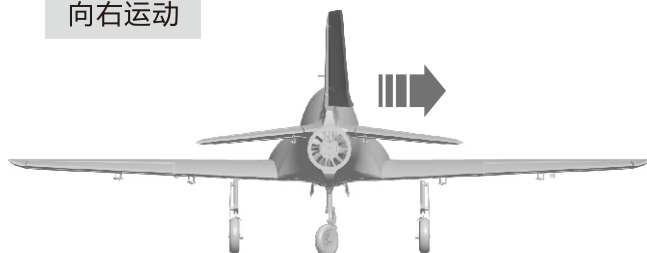
方向摇杆
向左运动方向摇杆
向右运动

襟翼

襟翼放下

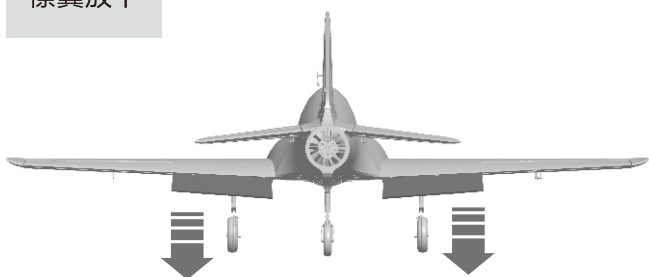

大、小舵参数

根据我们的测试经验，我们认为，按以下参数来设置大小舵量，将有助于飞行。小舵量飞机的操纵会笨拙些，大舵量飞机的操纵会灵敏些，我们建议初次飞行使用大舵量起飞，然后视操纵习惯选用小舵量或者大舵量飞行。

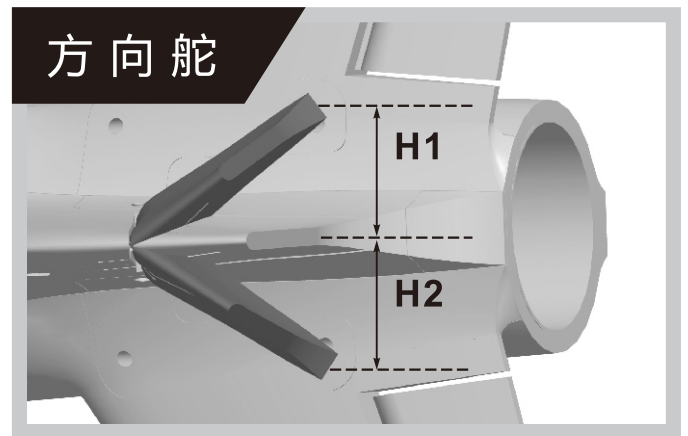
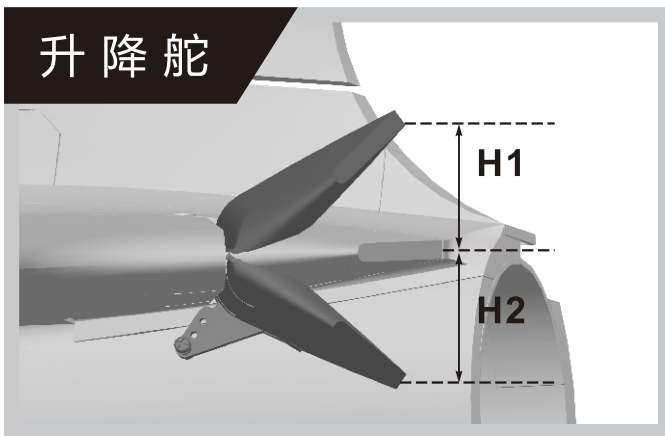
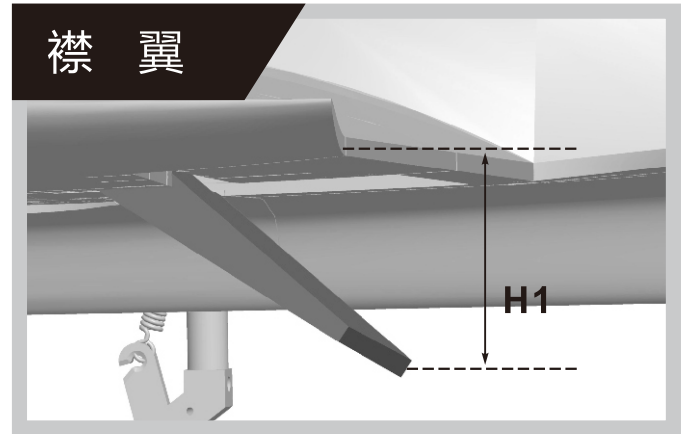
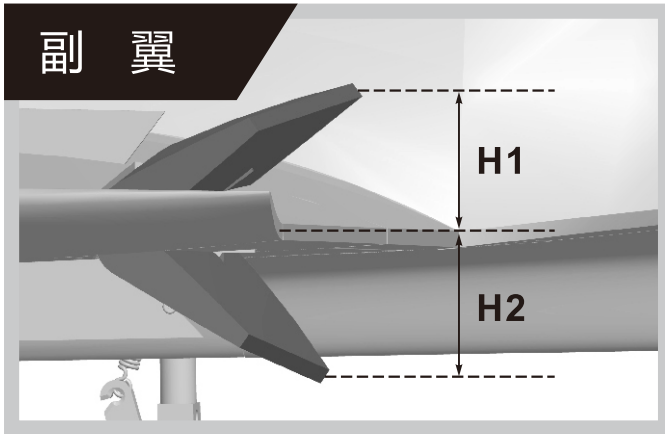

	副翼	升降舵	方向舵	襟翼
小舵量	H1/H2 19mm/19mm 舵量比率：70%	H1/H2 22mm/22mm 舵量比率：85%	H1/H2 39mm/39mm 舵量比率：85%	H1 23mm
大舵量	H1/H2 26mm/26mm 舵量比率：100%	H1/H2 25mm/25mm 舵量比率：100%	H1/H2 46mm/46mm 舵量比率：100%	H1 55mm

⚠ 飞行注意事项：襟翼下放飞机有抬头现象，需要混控升降舵才能很好的降落，小舵量襟翼需要1mm降舵，大舵量襟翼需要2mm降舵。

舵机使用说明

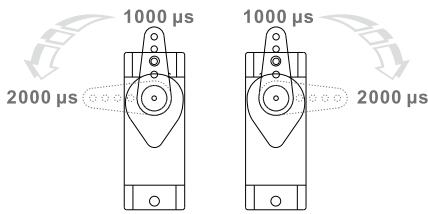

我们的舵机正、反向标准是：
当舵机输入信号从1000µs到2000µs时，
如果舵机摇臂，
顺时针旋转---正向舵机
逆时针旋转---反向舵机

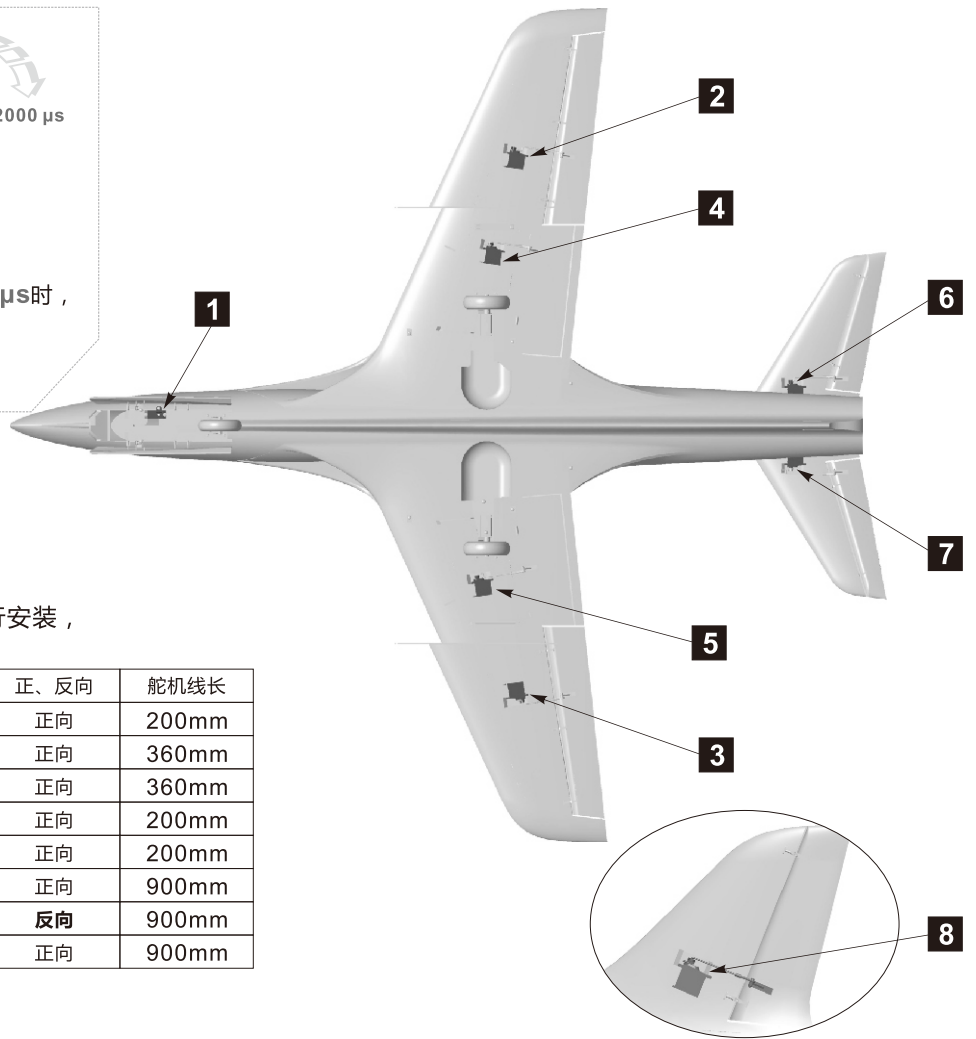

如果您需要选购其它品牌的舵机进行安装，
请参考下面的表格选择正确的舵机

舵机位置	舵机规格	序号	正、反向	舵机线长
前轮转向	9g 数码-金属	1	正向	200mm
副翼(左)	9g 数码-金属	2	正向	360mm
副翼(右)	9g 数码-金属	3	正向	360mm
襟翼(左)	9g 数码-金属	4	正向	200mm
襟翼(右)	9g 数码-金属	5	正向	200mm
平尾(左)	9g 数码-金属	6	正向	900mm
平尾(右)	9g 数码-金属	7	反向	900mm
垂尾	9g 数码-金属	8	正向	900mm

电机参数

#MOI36585
3658-2150KV

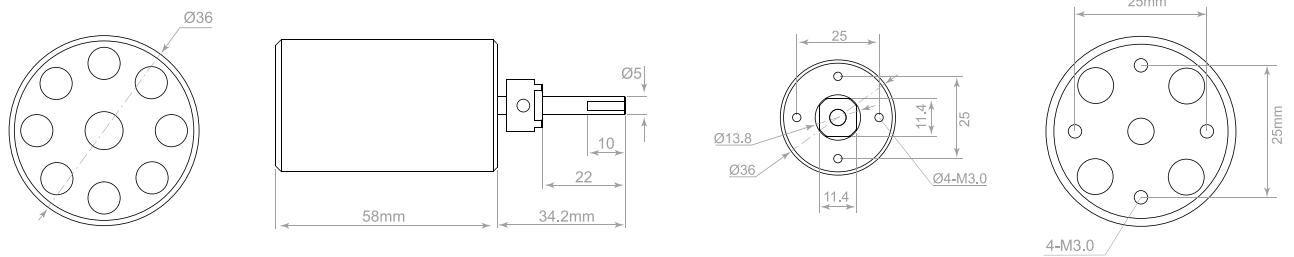

Unit: mm

Item No.	Fan size	Motor specifications	Voltage (V)	Current (A)	Max power (W)	Thrust (g)	Efficiency (g/w)	Speed (rpm)	Weight (g)
E72314	80mm 12-Blade	3658-2150KV	22.2	95	2100	3550	1.7	47700	340

主翼钢丝安装

- 1.通过舵机测试仪或者遥控器，把舵机摇臂校正到居中位置；
- 2.用胶水分别把舵机和舵面摇臂粘到主翼上；
- 3.将舵机线卡到舵机线槽内，等所有主翼舵机安装完成，贴上贴纸；
- 4.钢丝一端穿入到舵机摇臂后，调节钢丝长度，在保持舵面居中的情况下，将夹头扣入舵面摇臂内；
- 5.重复以上4个步骤，安装襟翼舵机和另外一侧主翼舵机。

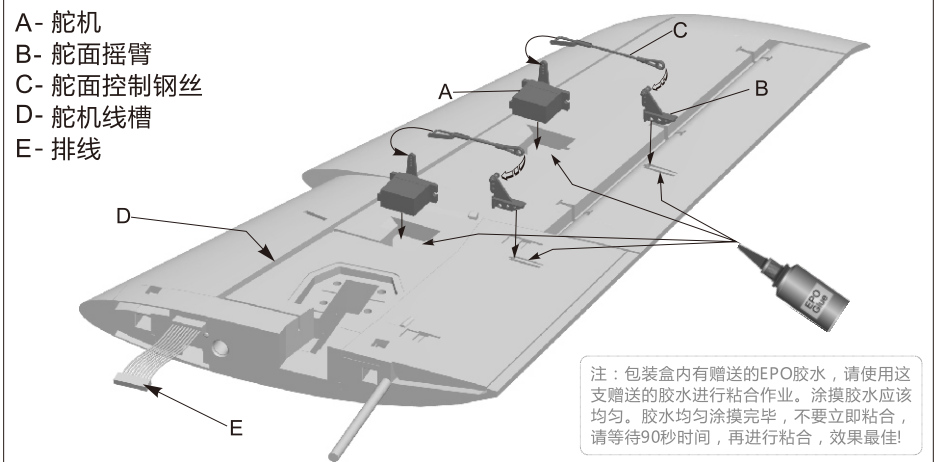

平尾钢丝安装

- 1.通过舵机测试仪或者遥控器，把舵机摇臂校正到居中位置；
- 2.用胶水分别把舵机和舵面摇臂粘到平尾上；
- 3.将舵机线卡到舵机线槽内，等所有平尾舵机安装完成，贴上贴纸；
- 4.钢丝一端穿入到舵机摇臂后，调节钢丝长度，在保持舵面居中的情况下，将夹头扣入舵面摇臂内；
- 5.重复以上4个步骤，安装另外一侧平尾舵机。

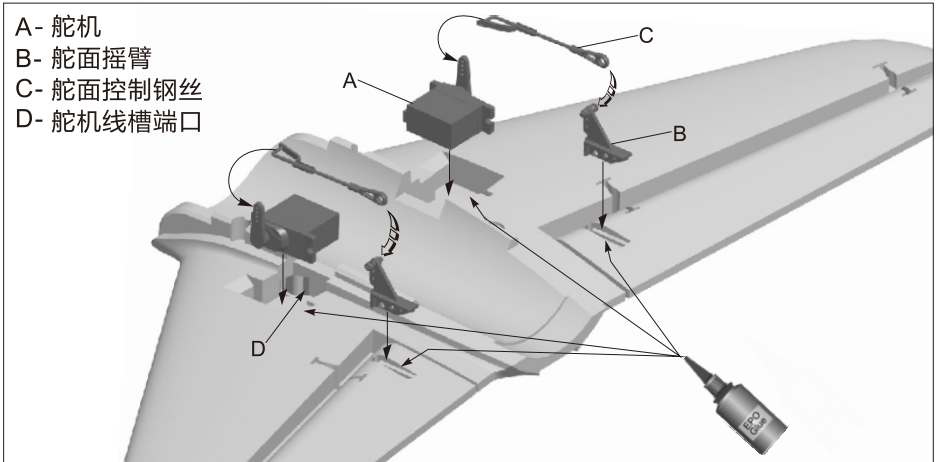

垂尾钢丝安装

- 1.通过舵机测试仪或者遥控器，把舵机摇臂校正到居中位置；
- 2.用胶水分别把舵机和舵面摇臂粘到垂尾上；
- 3.将舵机线卡到舵机线槽内，等所有垂尾舵机安装完成，贴上贴纸；
- 4.钢丝一端穿入到舵机摇臂后，调节钢丝长度，在保持舵面居中的情况下，将夹头扣入舵面摇臂内；

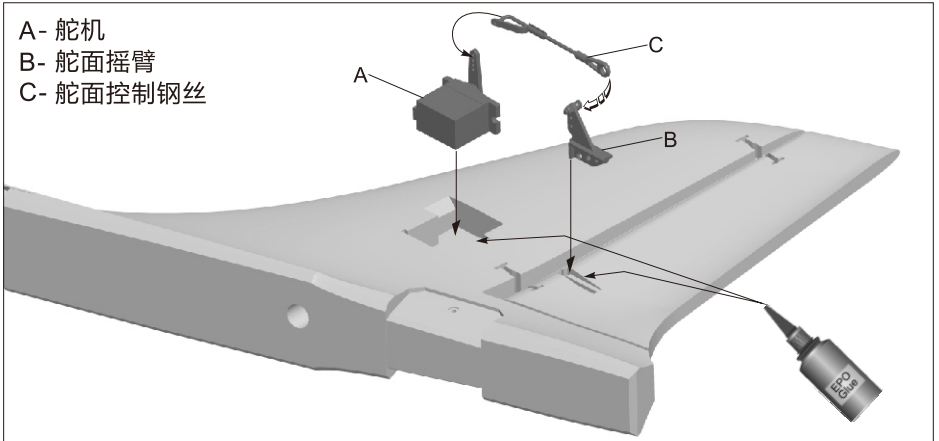

重要附加说明：

本产品所使用的“Y”型夹头，均配备了透明硅胶圈进行二次加固，能有效防止夹头意外松开。如下图所示，当您将夹头扣入舵面摇臂后，请使用硅胶圈套住夹头。

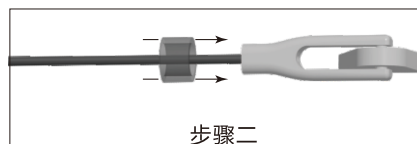
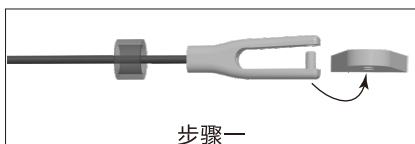

前起落架组装

请参考以下图示、组装、更换、维修前起落架

配件名称及规格参数

- A- E型扣 (M3)
- B- 前机轮 (Ø65x16mm)
- C- 前轮轴
- D- U型斜撑杆
- E- 梢钉 (Ø3.5x10.2mm)
- F- E型扣 (M1.5)
- G- 减震活动杆
- H- 弹簧
- I- 8字型减震转轴
- J- 前轮主撑杆固定圈
- K- 螺丝 (PM2x3 1pcs)

- L- 梢钉 (Ø3.5x9.2mm)
- M- E型扣 (M1.5)
- N- 螺丝 (PM2x3 1pcs)
- O- 前起落架主撑杆
- P- 梢钉 (Ø3.5x10.2mm)
- Q- E型扣 (M1.5)
- R- 机米螺丝 (M4x3mm)
- S- L型摇臂
- T- 机米螺丝 (M3x3mm)
- U- 前起落架转向控制环
- V- 前起落架转向钢丝

- W- 金属转轴
- Z- 前起落架主钢丝
- AB- 螺丝 (PA1.4x12 2pcs)
- AC- 螺丝 (PA1.7x10 4pcs)
- AD- 螺丝 (FA3x12 4pcs)
- AE- 起落架加强金属板
- AF- 前起落架组件
- AG- 前起落架控制钢丝
- AH- 螺丝 (PWA2.3x8 2pcs)
- AI- 舵机
- AJ- 前起落架随动舱门
- AK- 舱门扭簧
- AL- 螺丝 (PA2x8 4pcs)
- AM- 弹簧

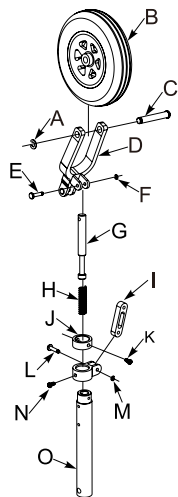

步骤 1

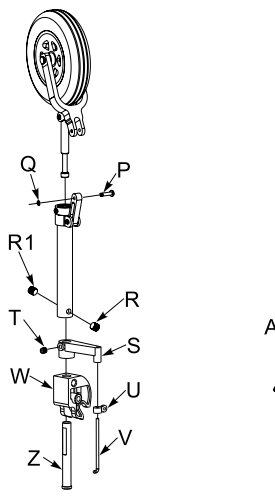

步骤 2

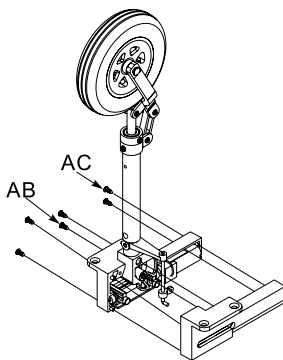

步骤 3

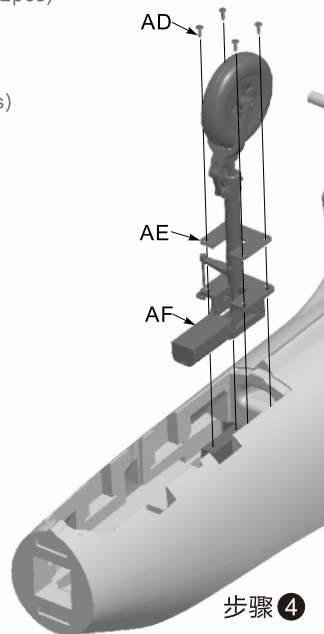

步骤 4

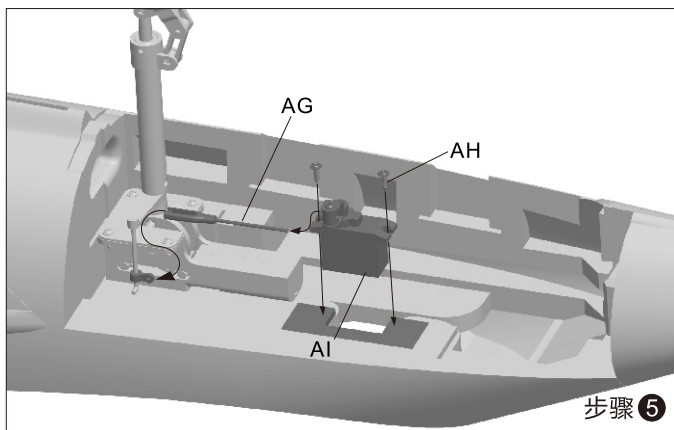

步骤 5

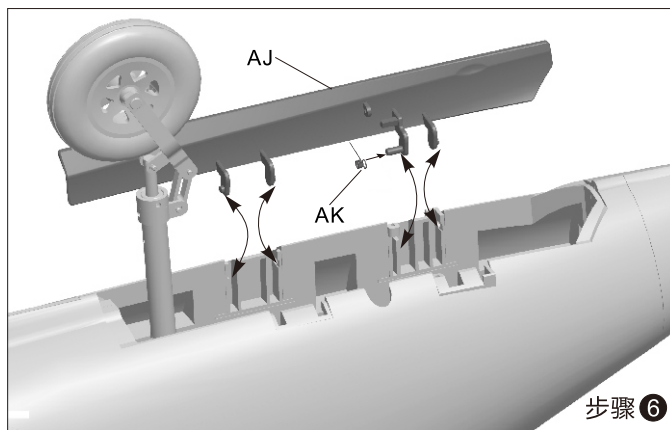

步骤 6

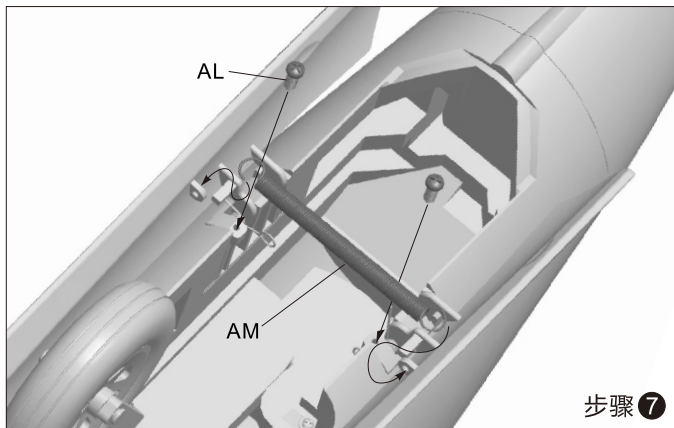

步骤 7

起落架转向控制钢丝尺寸

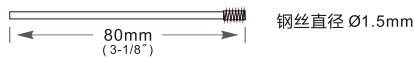

转向舵机钢丝安装孔位



注意：在整个起落架组装过程中，所有带扁口的零件，在用螺丝固定时，扁口面必须面向螺丝孔，只有这样，螺丝的固定才是有效的，零件才不会转动和脱落。

后起落架组装

请参考以下图示、组装、更换、维修后起落架

配件名称及规格参数

- A - 轮轴
- B - 机轮 (Ø70x20mm)
- C - 机米螺丝 (M4x4mm 1pcs)
- D - 后起落架斜撑杆
- E - 后起落架主撑杆A
- F - 机米螺丝 (M4x3mm 2pcs)
- G - 后起落架主撑杆B
- H - 弹簧
- I - 螺丝 (PM3x4mm 1pcs)
- J - 机米螺丝 (M4x3mm 2pcs)
- K - 后起落架钢丝
- L - 电动起落架收放控制器
- M - 机米螺丝 (M4x3mm 2pcs)
- N - 螺丝 (PM2x5mm 2pcs)
- O - 后起落架随动舱门
- P - 螺丝 (FA3x12mm 4pcs)
- Q - 后起落架组件
- R - 后起落架固定座

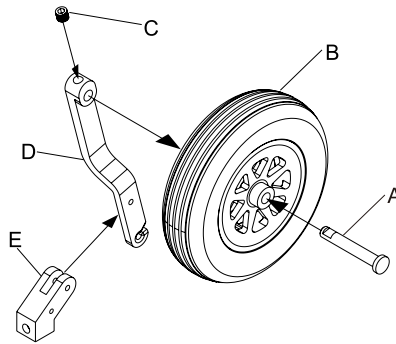

步骤 1

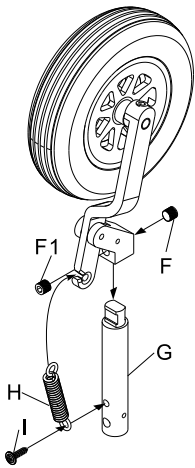

步骤 2

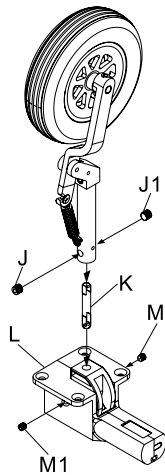

步骤 3

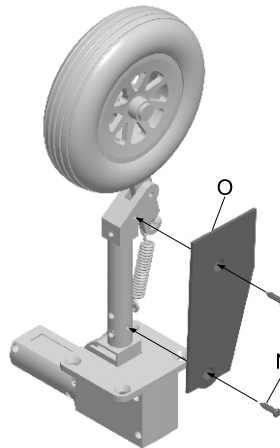

步骤 4

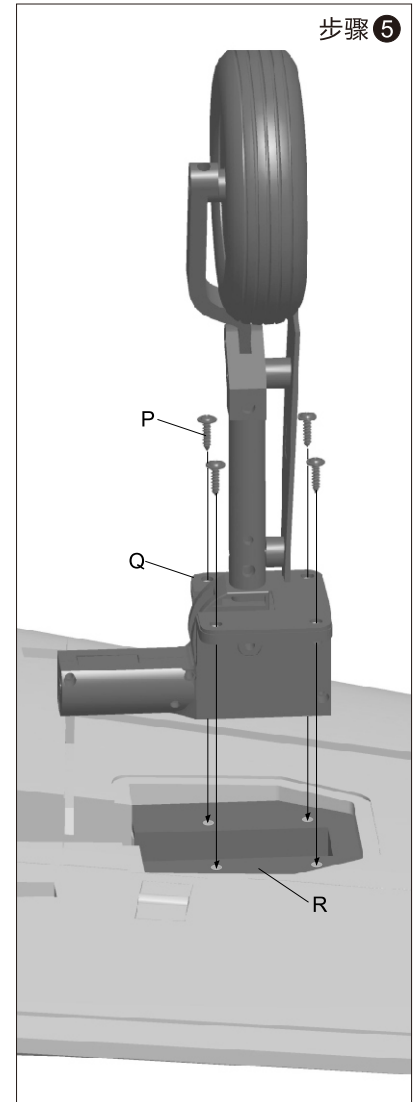

步骤 5

翼刀安装

如图所示：
使用美工刀沿着主翼顶端位
切开翼刀凹槽，深度3mm，
厚度2mm，长度153mm，
然后涂抹胶水后，将翼刀插
入翼刀凹槽内。

注：本产品提供了翼刀配件，供
您自主改装。安装翼刀后，模型
飞机的横向稳定性更佳，在做某
些特技动作时，飞行姿态更加稳
定！

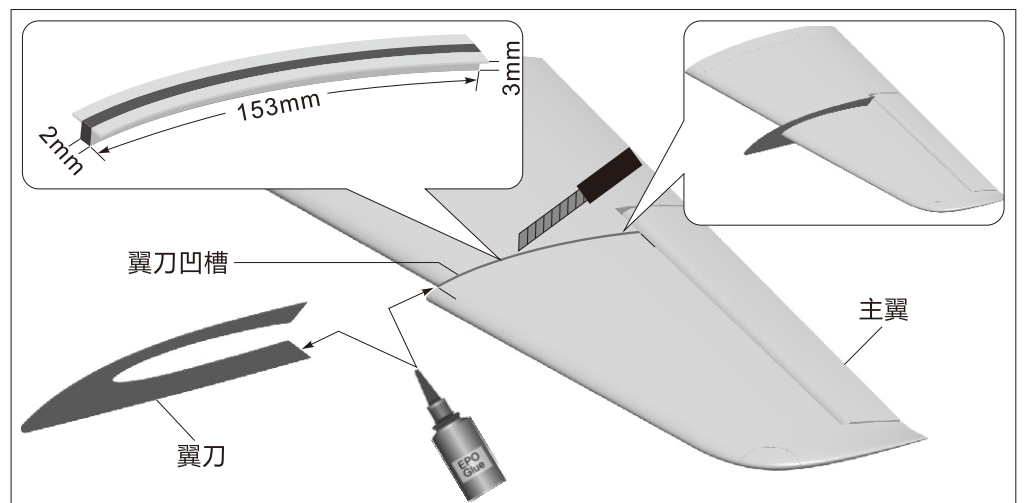



Dongguan Freewing Electronic Technology Ltd
HK Freewing Model International Limited

Add.: Fei Yi Building, face to Labor Bureau, Fumin Middle Road, Dalang Town,
Dongguan City, Guangdong Province, China

Web: <http://www.sz-freewing.com> www.freewingmodel.com

Email: freewing@sz-freewing.com

Tel: 86-769-82669669 Fax: 86-769-82033233

东莞市飞翼电子科技有限公司
香港飞翼模型国际有限公司

地址: 广东省东莞市大朗镇富民中路402-408号飞翼楼四楼

Web: <http://www.sz-freewing.com> www.freewingmodel.com

Email: freewing@sz-freewing.com

Tel: 86-769-82669669 Fax: 86-769-82033233

