

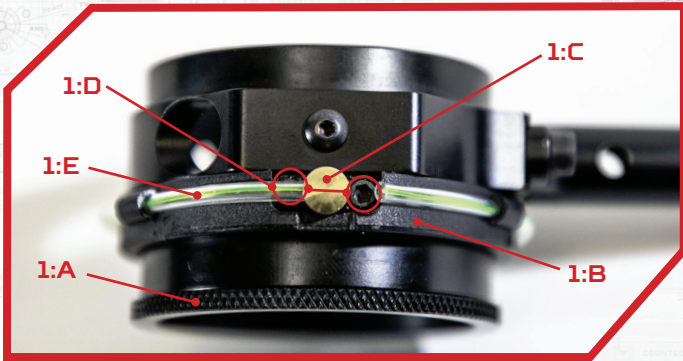

CUSTOM BOW EQUIPMENT

VTX SCOPE INSTRUCTIONS



A 3/8"-24 sight light can also be threaded into the end of the scope tube (4:A), if the scope is being used with the CBE Vertex Elevate. There is a hole in the scope tube to route the fiber tube into the light (4:C). Pull the fiber tube out of one loop on the fiber tube ring (1:B) and run it through one of the holes on the scope tube (4:C).

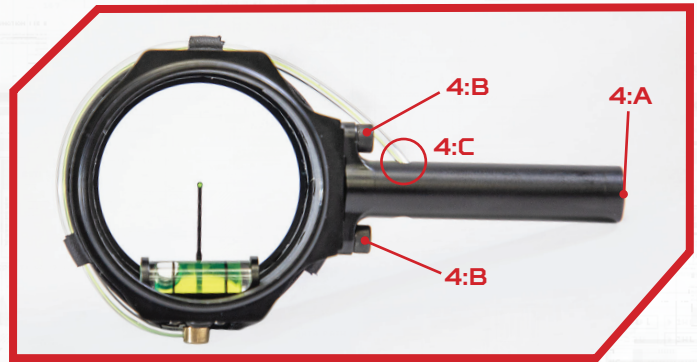

CHANGING PIN LOCATIONS

This scope housing has 8 pin mounting locations(2:A). To relocate the pin to another location, remove the threaded lens retaining ring from the housing(1:A). Next, pull the fiber ring (1:B) off of the housing (it may be necessary to pry this off) and rotate the brass plug (1:C) so that the #2-56 screws are accessible (2:B). Remove both of the #2-56 screws (1:D) and relocate the pin to the desired location. Reinstall the screws to fasten the pin in place and reinstall the fiber ring (1:B). Make sure that the fiber tube (1:E) remains in the brass plug.



MOUNTING SCOPE TO SIGHT

This scope has different mounting options for mounting it on multiple different sights. The scope comes assembled with the included CBE scope tube to be used with the CBE Vertex Elevate. There is also an adapter (5:A) provided for use with the CBE Vertex. To use this scope housing with a CBE Vertex, the adapter must be attached to the vertex windage tube using the #10-32 flat head screw provided with the sight (5:B). Next, remove the scope tube from the scope housing by removing the 2 #6-32 screws (4:B). Attach the adapter to the scope housing using the 2 #6-32 screws that were removed. There is a #10-32 threaded rod included with the scope housing for use when the adapter will not work properly.

MOUNTING LIGHT TO SCOPE

There are multiple ways that a light can be mounted to this sight. The base of the pin is threaded for an #8-32 sight light (3:A). First, remove the fiber ring (1:B). Next, as shown above remove the fiber tube from the brass plug and remove the brass plug (1:C). The fiber must be trimmed to length, so the light can be threaded into the pin. Trim the fiber so that it is slightly protruding from the bottom of the pin (3:A). The end of the fiber must then be flared for the best results. Install the light by threading it into the pin (3:B).

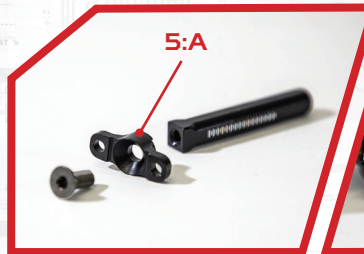



CBE[®]

CUSTOM BOW EQUIPMENT

THANK YOU FOR CHOOSING CUSTOM BOW EQUIPMENT!

WARRANTY SERVICES:

IMPORTANT: In the unlikely event that you require service on your product, please contact Customer Service at 1 (877) 503-5483.

If necessary, our Customer Service Agents will provide you with a Return Merchandise Authorization (RMA) number and instructions on how to ship the product(s) back. It's important that you contact a Customer Service Agent before returning any item. Please be sure to include your RMA number when returning an item, so that we can identify the return as yours. **Without the RMA, we will not be able to process your return, and your item will not be returned to you.**

PATENT INFORMATION

This product is covered by one or more patents. A complete list of Custom Bow Equipment patents can be found by visiting custombowedquipment.com/pages/patents

**TOUGH AS NAILS
GUARANTEE**

THE OUTDOOR GROUP, LLC

1325 John Street, West Henrietta, NY 14586

(877) 503-5483

[www.custombowedequipment.com](http://www.custombowedquipment.com)



LIABILITY DISCLAIMER

The Outdoor Group, LLC is not liable for any personal injury, death, or property damage that may result from your use of this product. The user of this product assumes all risks of property damage or injury to yourself and others that may arise from its use. Use of this product binds the user to this agreement.