



Model 2000KL Stretcher / In-Bed Patient Scale



User Instructions

Thank you for your purchase of this Health o meter® Professional product. Please read this manual carefully, and keep it for easy reference or training.

TABLE OF CONTENTS

Caution and Warning.....	3
Specifications for This Scale	5
Certifications / Connectivity / Disposal	6
Assembly Instructions 2000KL Scale	7
Setup / Batteries.....	17
Operating Instructions	17
Maintenance.....	22
Calibration	23
Troubleshooting	24
Warranty.....	25

Note: This scale has been factory calibrated, and does not require calibration prior to use.

Please register your scale for warranty coverage at:

www.homscales.com

For User Instructions updates and revisions please go to:

www.homscales.com

CAUTION AND WARNING

- To prevent injury and damage to your scale, please follow these instructions very carefully.
- Assemble and operate the scale per the enclosed user instructions.
- Operate this scale exclusively with the AC adapter provided by Health o meter Professional. Use of an unspecified adapter will void the warranty, and can pose a serious safety hazard.
- Prior to using this scale, inspect the AC adapter cord for cracking / fraying, or for broken / bent plug prongs.
- Prior to using this scale, ensure that the AC adapter is plugged into an outlet with the rated voltage appropriate for operation.
- Ensure that the AC adapter outlet is wired to a circuit breaker or other protected power source.
- Unplug the AC adapter, and carefully store both the adapter and adapter cord before moving the scale.
- Ensure that the AC adapter and scale do not come in contact with liquids, excessive temperature, or excessive humidity.
- Operating this scale at voltages and frequencies other than specified can damage the equipment and will void the warranty.
- Do not exceed recommended weight limit of 400 lb / 181 kg for this scale.
- For accurate weighing, this scale must be placed on a flat, stable surface.
- For accurate weighing, the casters on the lifter base must be placed on a flat and stable surface with the weighing mechanism not touching the floor.
- For accurate weighing, verify before each use the proper operation according to the procedure described in this manual.
- Do not use in the presence of flammable or explosive materials.
- For accurate weighing, if the “Lo bAtt” indicator activates, replace the batteries or switch to the AC adapter as soon as possible.
- If the scale becomes damaged, it should not be operated until properly serviced. All repairs should only be performed by authorized Health o meter[®] Professional service personnel.
- This scale is designed for static weighing of patients only. No scale should be used for patient transfer. Pelstar, LLC assumes no responsibility for patient injury or scale damage should this caution be ignored by the scale operator.

CAUTION AND WARNING

- Do not leave patients unattended while patient is being weighed on the scale.
- When replacing / inserting batteries, be sure to use all new batteries.
- For maximum safety, ensure stretcher is positioned above a bed or a similar surface.
- When weighing a patient, position the patient as close to the bed as possible.
- When weighting a patient, adjust lifter base in the widest position.
- Do not lock or block lifter base wheels while lifting. Wheels must roll freely when positioning a patient.
- When transporting scale, do not push or pull on lifter mast. Move the scale by using steering handles only.

SPECIFICATIONS FOR THIS SCALE

General

The Model 2000KL stretcher scale uses highly sophisticated microprocessor technology. Each precision scale is designed to provide accurate, reliable and repeatable weight measurements. In addition, each scale is designed to provide the user with features that make the weighing process simple, fast, and convenient.

This scale is set up to use motion-sensing weighing technology in order to determine the actual weight of a moving patient.

Weight can be displayed in pounds (lb) or in kilograms (kg). This scale features a folding stretcher for easy mobility. It also has a 90° swivel display head for privacy and easy operator reading from either side of the scale. This scale has 4 wheels built-in for easy mobility. **This scale can be powered using an AC adapter (included), or by 6 - AA batteries (not included).**

2000KL Scale Specifications

Capacity and Resolution	400 lb x 0.2 lb (181 kg x 0.1 kg)	
Power Requirements	120 - 240VAC, 50 - 60Hz - 9V DC adapter (included) or 6 - AA batteries (not included)	
Environmental	Operating temperatures: 50°F to 95°F (10°C to 35°C) Storage temperatures: 30°F to 125°F (0°C to 50°C) Maximum Humidity: 85% RH	
Physical Dimensions	Closed Length: 70 7/8" (180 cm) Width: 6" (15 cm) Weight: 17.6 lb (8 kg)	Fully extended Length: 70 7/8" (180 cm) Width: 29 1/2" (75 cm)

CERTIFICATIONS / CONNECTIVITY / DISPOSAL

Certification Descriptions

	<p>Pelstar, LLC has been officially certified as the manufacturer of Health o meter® Professional medical devices. The Pelstar, LLC quality assurance system covers the development, production, sales and service of medical scales and measuring systems.</p>
---	---

2000KL Scale Connectivity Information

To enable reliable transmission of weight, height, and Body Mass Index (BMI) data, this scale is designed to connect to a computer, monitor, or other electronic device via a built-in USB port. This connectivity helps minimize a source of potential medical errors caused by incorrectly copying and then recording patient data.

This scale is EMR-EHR compatible. For more information regarding how to connect this scale to other electronic devices, please contact Health o meter® Professional Scales Technical Support, available during normal business hours at 1-800-638-3722.

2000KL Scale Disposal



This Health o meter® Professional scale must be disposed of properly as electronic waste. Follow the national, regional or local regulations which apply to you for disposal of electronic waste or batteries. Do not dispose of this device in the domestic waste stream.

2000KL ASSEMBLY INSTRUCTIONS

Before Assembly

Each 2000KL stretcher scale is shipped disassembled in (3) separate cartons. Carefully inspect all cartons for shipping damage before unpacking. If damage is found, contact your shipper or a Health o meter® Professional representative immediately at 1-800-815-6615. Claims must be filed with the shipper as soon as possible after receipt of the packages. The following information details what you will find inside the cartons as you unpack the parts for assembly.

To prevent scratching any components, carefully remove parts from the cartons and unwrap the packing materials. Set the cartons aside for storage. To avoid damaging the scale parts when unpacking, do not use a box cutter, knife, scissors, or any sharp object to open the protective inner packaging.

Parts List

Carton 1

- (1) Lifter mast
- (1) Hydraulic pump assembly
- (1) Base adjustment lever
- (1) Lifter base with caster

Carton 3

- (2) Stretcher bars

Carton 2

- (1) Stretcher holder
- (1) Lifter boom
- (1) Stretcher canvas
- (1) Scale Display Support
- (1) Load cell beam assembly
- (2) Stretch hoop
- (1) Small brown box

The small brown box contains:

- (1) Display assembly
- (1) Box containing the AC adapter
- (1) User Information
- (1) Long white box

The long white box contains:

- (1) AC adapter holder
- (1) Stretcher retaining strap
- (2) Pivot bracket screw covers
- (1) Plastic bag

The plastic bag containing:

- (1) 5mm Allen wrench
- (1) 4.5mm Allen wrench
- (2) Fork joints
- Hardware for assembly (see Figure 1)

Tools Required

Phillips head screwdriver (not included), Flat head screwdriver (not included), Allen wrenches (included), Adjustable wrenches (not included).

2000KL ASSEMBLY INSTRUCTIONS (CONTINUED)

Assembling the 2000KL Scale (Refer to Figures 1 - 12)

Caution: It is recommended that the assembly be performed by two persons.

Assembling the Patient Lifter

1. Remove the lifter base from the carton and place the lifter base on a flat, level and dry surface (see Figure 2).
2. Place the stretcher holder onto the lifter base (see Figure 3).
3. Remove black plastic protective caps from lifter mast (see Figure 3).
4. Insert the bottom of the lifter mast and hydraulic pump assembly into the mast sleeve (through the stretcher holder) on the lifter base (see Figures 2 & 3).
5. The notch on the end of the lifter mast fits over the round tube at the bottom of the mast sleeve (see Figure 3).
6. Position and lock the lifter mast into the mast sleeve. When assembled correctly, the lifter mast will not be able to rotate (see Figure 3).
7. Check that the lifter mast is locked into position, and that the hole in the lifter mast is aligned with the threaded hole in the mast sleeve (see Figure 3).
8. Screw the knob into the threaded hole in the mast sleeve. Tighten to lock the lifter mast to the lifter base (see Figure 3).

Note: Keep lifter mast and lifter base locked at all times, except when removing lifter mast from the lifter base for storage.

9. Locate the NC 3/8 – 20 x 2½” hexagon head screw (see Figure 1, Fastener “I”).
10. Insert the hexagon head screw through the stretcher retaining strap eyelet hole. The screw can be inserted through either side of the strap (see Figure 4).
11. Locate the self lock nut (see Figure 1, Fastener “V”).
12. Using the same hexagon head screw, assemble the lifter boom and the display support to the lifter mast. Thread the screw through all three parts, and secure the screw with the self lock nut (see Figure 4).

Note: Ensure that the lifter boom hooks are facing down during patient lifter assembly.

13. Locate the NC 3/8 – 20 x 1 ¾” hexagon head screw and self lock nut (see Figure 1, Fastener “II” and “V”).
14. Insert the end of the hydraulic pump shaft into the lifter boom’s bracket, and align the assembly holes (see Figure 4).
15. Thread the hexagon head screw through the lifter boom bracket and the hydraulic pump shaft hole. Secure the screw with the self lock nut (see Figure 4).
16. Insert the base adjustment lever into its socket at the back of the lifter base. Check to see that the positioning ball on the outside of the base of the adjustment lever fits securely in the socket (see Figure 5).

2000KL ASSEMBLY INSTRUCTIONS (CONTINUED)

17. To adjust the lifter base with casters, unlock the legs by pulling back on the adjustment lever. Move the lever to the right in order to widen the base (see Figures 5 & 8).
18. A caster lock is provided on the lifter base to prevent movement. To lock caster, step on caster lock lever on side of caster. To unlock, step on higher cam lever (see Figure 7).

Warning: Never lock caster lock or block casters when lifting a patient.

Note: Caster lock is provided for preventing mobility only.

19. To operate the hydraulic pump, pump the handle in an upward and downward motion to elevate the lifter boom. Make certain the control valve knob (located on the hydraulic pump near the handle) is fully tightened clockwise. This enables the hydraulic pump to be operational (see Figure 6).
20. To lower the lifter boom, slowly turn the control valve knob counterclockwise. The rate of descent can be controlled by varying the knob's position. The lifter boom may not lower readily without weight. To test, simply apply downward force to the lifter boom (see Figures 6 & 8).

Note: If screws, mounting pump, or lifter mast are too tight, the lifter boom may not lower properly.

Assembling the Display Assembly

21. Position the display assembly close to the display support. Connect the load cell cable connector to the load cell port on the rear of the display assembly (see Figures 2, 4 & 10).
22. Align the four mounting holes on the back of the display assembly with the four mounting holes in the display support. Fasten the display assembly onto the metal display support by using (4) Phillips pan head M4 screws (VIII). Use Phillips head screwdriver to tighten the screws (see Figures 1 & 9).
23. Place the pivot bracket screw covers over the pivot screws. Fasten the covers to the back of the display using (4) Phillips pan head M4 screws (VIII). Use Phillips head screwdriver to tighten the screws (see Figures 1 & 9).
24. Connect the AC adapter to the power port in the display. Do not plug the scale into a power source until the scale is fully assembled (see Figure 10).

Assembling the Stretcher

25. Hang the load cell beam assembly on the two hooks at the end of the lifter boom, using the loops on top of the load cell beam assembly (see Figure 11).
26. Connect the end of the load cell beam cable coming out of the center of the load cell beam assembly to its port on the side of the lifter boom (see Figures 11 & 12).
27. Connect the lock rings (IV) onto the two hooks at the end of the lifter boom, using a screwdriver to tighten the set screws (see Figures 1 & 11).
28. Use the hexagon shoulder screws (III) to connect the fork joint to the load cell beam assembly (see Figure 11).

2000KL ASSEMBLY INSTRUCTIONS (CONTINUED)

29. Use the hexagon shoulder screws (III) to connect the two stretcher hoops to the load cell beam assembly and securely tighten. Make sure that the stretcher hooks face each other in the inward position, toward the stretcher canvas (see Figures 1 & 11).
30. Insert the stretcher bars into the stretcher channel pockets on either side of the stretcher canvas. Confirm that the stretcher bars pass through the two hanging loops on each side of the stretcher canvas.
31. Ensure that both ends of the channel pockets are sealed, by squeezing the Velcro strips together (see Figure 11).

Note: The hanging loops are tethered to the stretcher fabric. Make certain that each stretcher bar passes through the hanging loops. The other portion of the hanging loop will go over the hooks of the stretcher hoops.

32. The scale is now assembled. Plug the AC adapter into a power source and / or insert batteries (see Figure 12).

2000KL ASSEMBLY INSTRUCTIONS (CONTINUED)

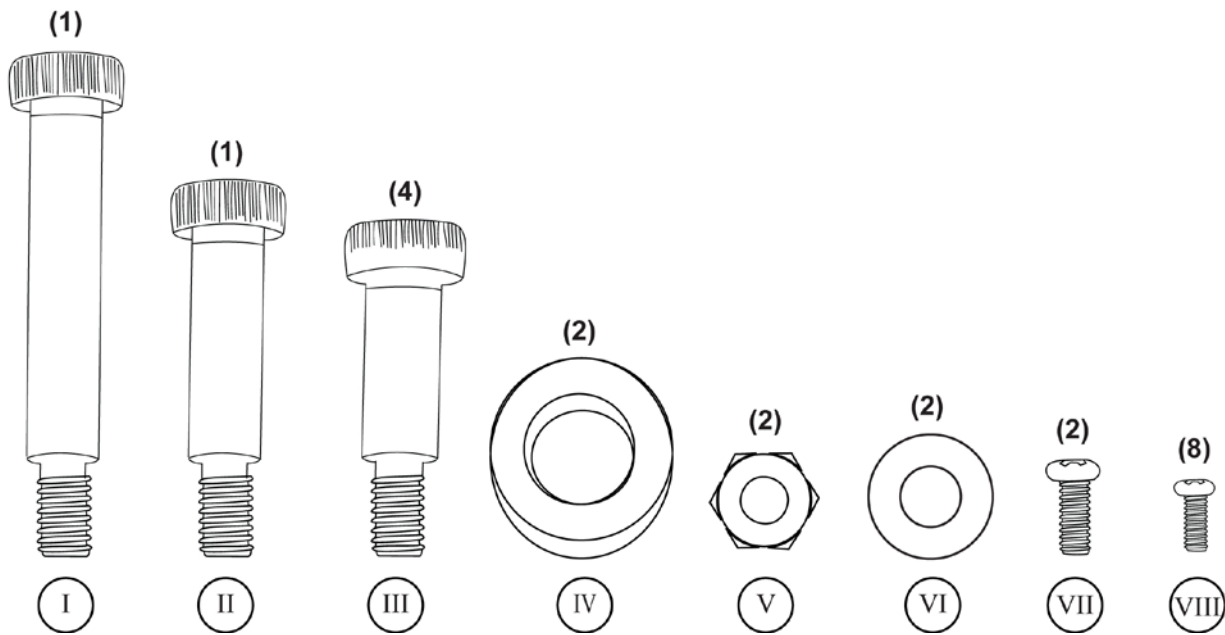

Figure 1

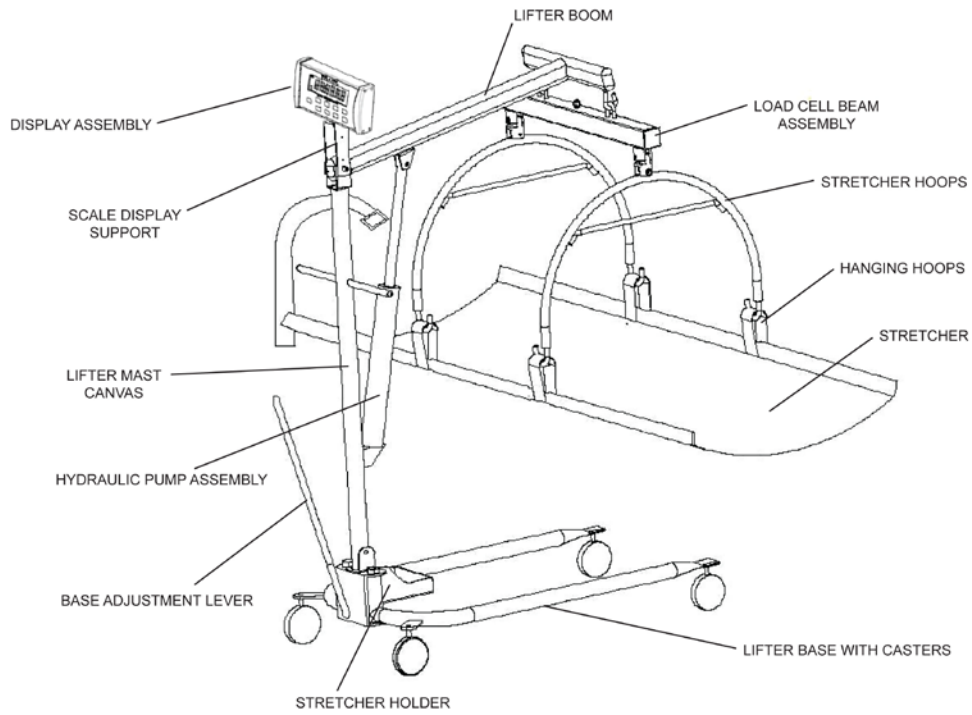

Figure 2

2000KL ASSEMBLY INSTRUCTIONS (CONTINUED)

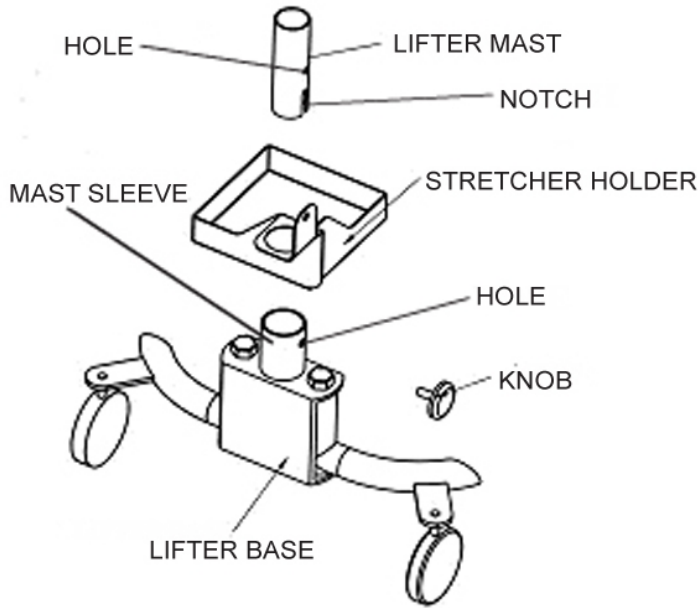

Figure 3

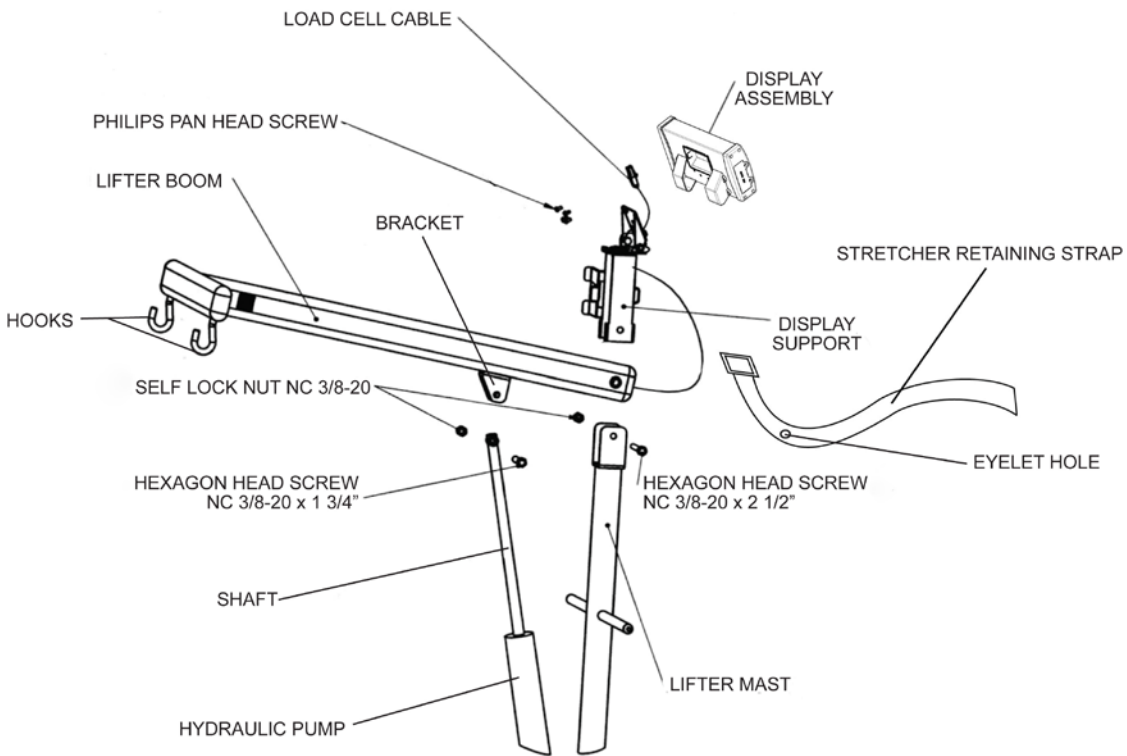

Figure 4

2000KL ASSEMBLY INSTRUCTIONS (CONTINUED)

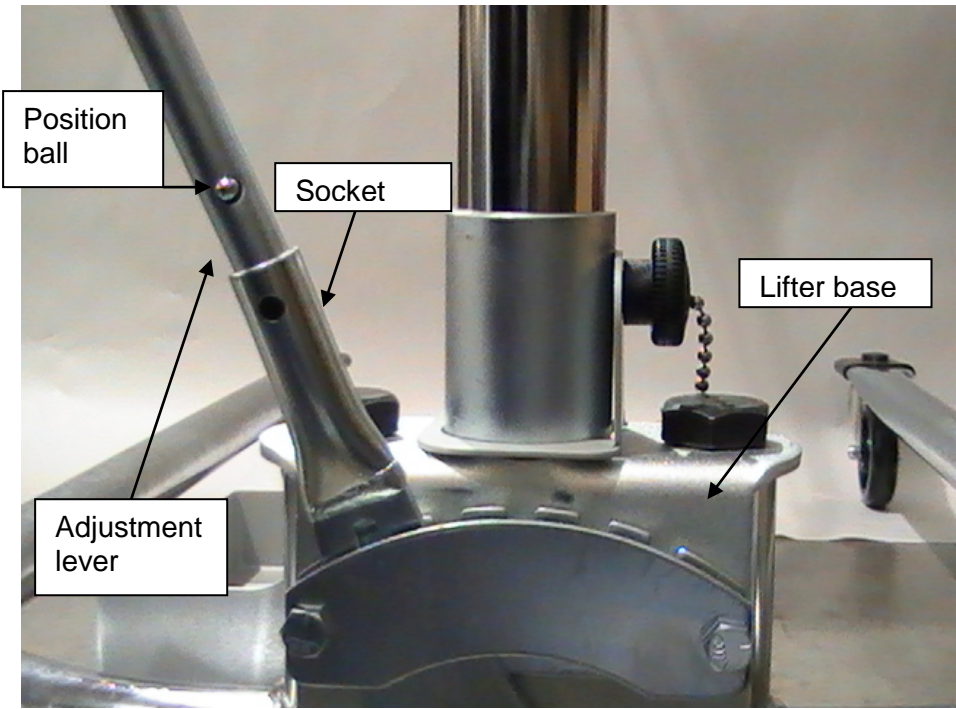

Figure 5

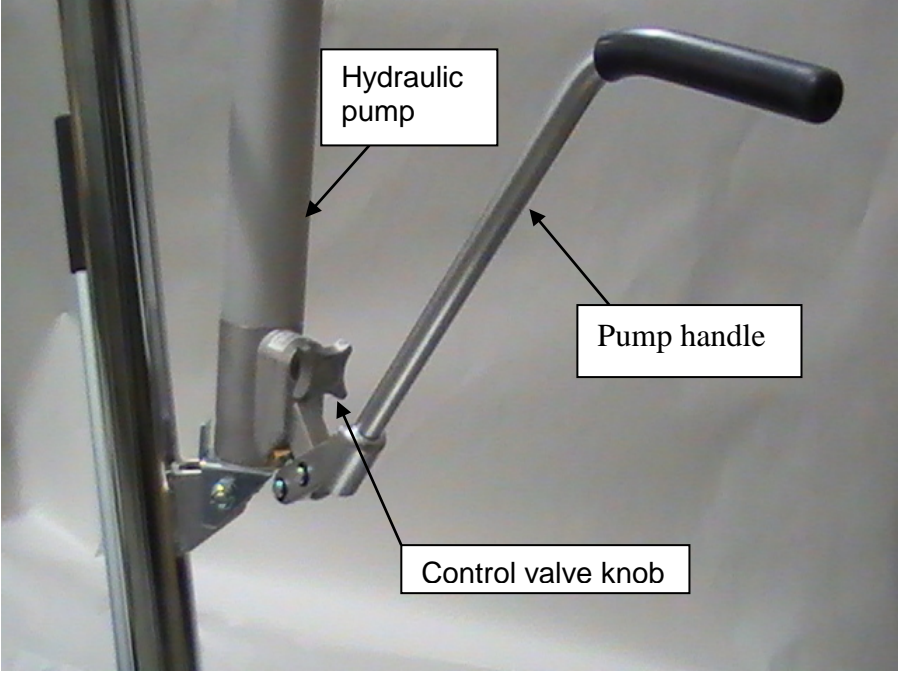

Figure 6

2000KL ASSEMBLY INSTRUCTIONS (CONTINUED)

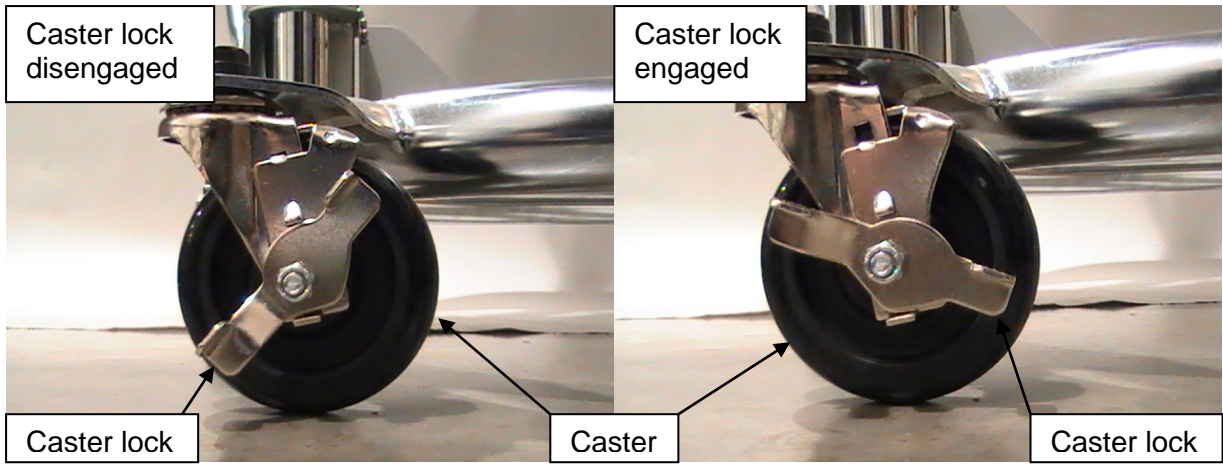

Figure 7

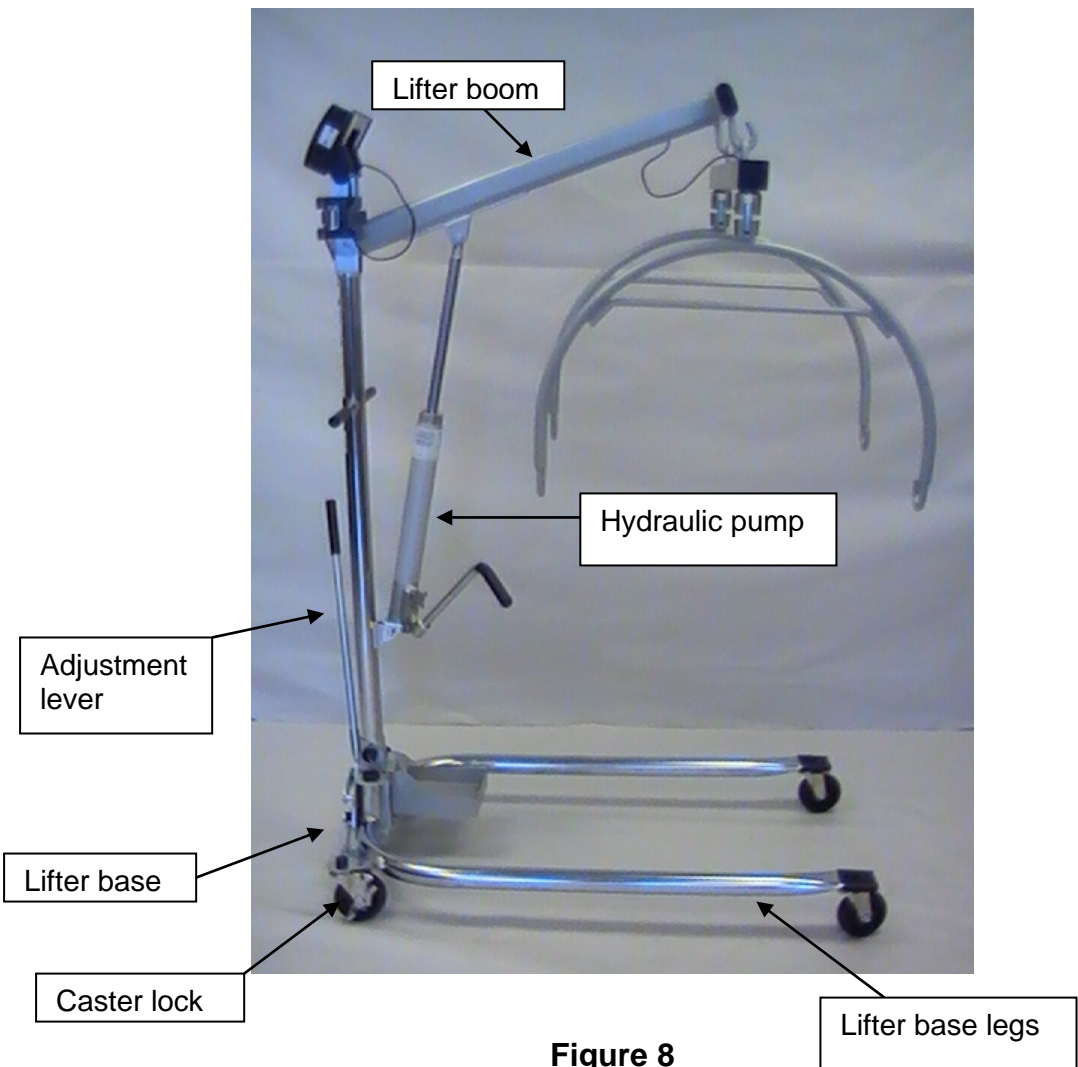

Figure 8

2000KL ASSEMBLY INSTRUCTIONS (CONTINUED)

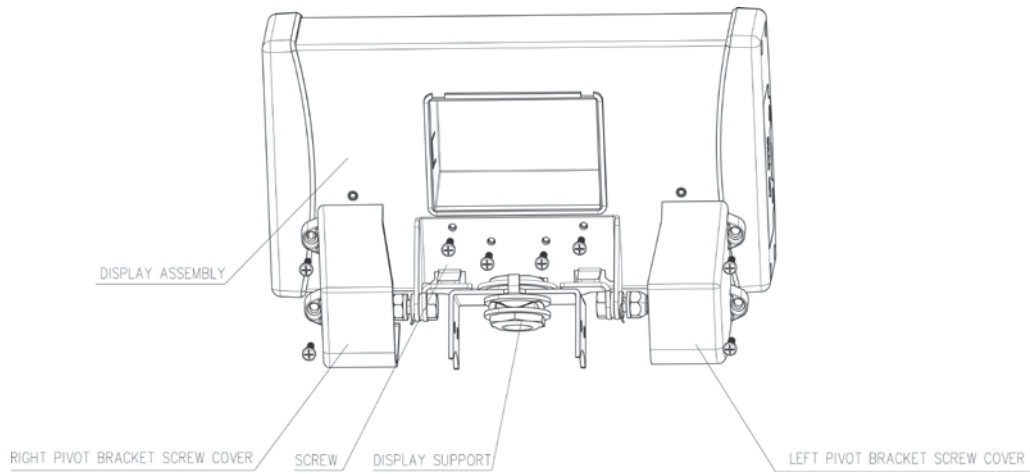

Figure 9



Figure 10

2000KL ASSEMBLY INSTRUCTIONS (CONTINUED)

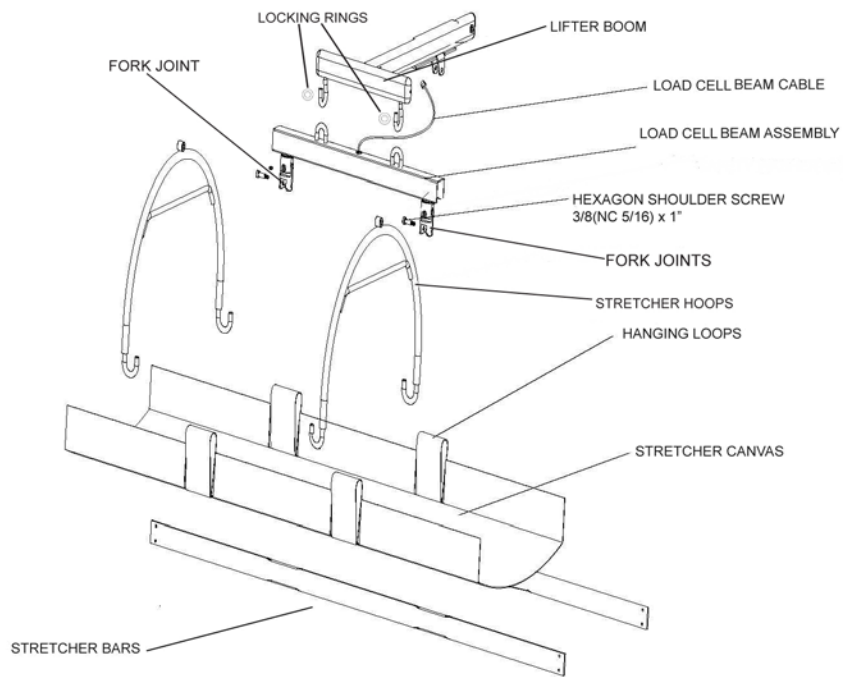

Figure 11



Figure 12

SETUP / BATTERIES/OPERATING INSTRUCTIONS

Powering the Scale

1. Plug the AC adapter into the power adapter jack (the jack is located on the rear of the display head), then plug the scale's AC adapter into the power source.

Warning: To avoid a safety hazard, do not use an unspecified AC adapter. Only use the Health o meter® Professional AC adapter model ADPT30 designed for this scale.



2. For battery operation, see Battery Installation below.

Battery Installation

1. If connected, unplug the AC adapter from the power source.
2. Use a Phillips head screwdriver to remove the battery cover on the side of the display head by unscrewing the (2) battery cover screws.
3. Replace or install fresh batteries, making sure to install them in the proper direction. Health o meter Professional recommends using an alkaline or lithium battery, rated for 130°F (54°C) operation. Do not use Zinc-Carbon batteries.
4. Re-attach the battery cover to the display head.

Warning: If the scale will not be used for some time, remove the batteries to avoid a safety hazard. Disposal of batteries must be performed in accordance with the prevailing national, regional or local regulations that apply to you.

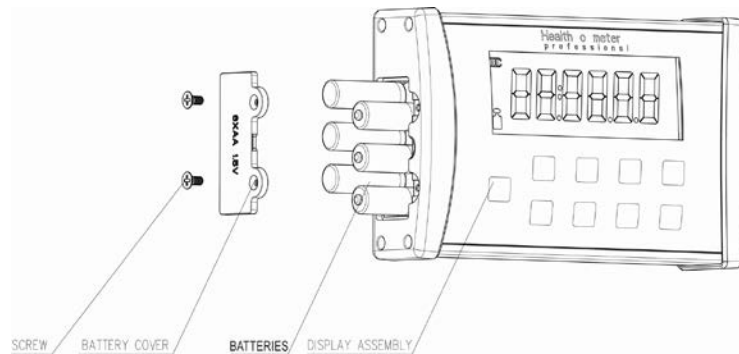

Figure 13

Preparing the 2000KL Scale for Use

1. Remove the protective plastic film covering the display head (the film is printed "FACTORY CALIBRATED").
2. Ensure all objects are removed from the scale and do not have the stretcher on the stretcher hoops. Press the **ON/OFF** button to turn the scale on. The display will show "Start", then "0.0" LB or "0.0" KG. Press the **UNIT** button to select the weight mode (LB or KG).
3. Hang the stretcher on the Stretcher Hoops. The display will begin to display weight information until a stable weight is calculated. The weight of the stretcher will be displayed. (See pages 21 and 22, on more information regarding pre-weighting the stretcher and the TARE function).

OPERATING INSTRUCTIONS (CONT.)

4. Press the **TARE** button and the display will zero out.

Note: This scale will always default to the settings and units last used (LB or KG).

5. When the AC adapter is disconnected from the scale, the scale will switch to battery power if batteries are installed.

Note: If the set up procedure failed, refer to the troubleshooting instructions. If the problem is not corrected, refer to qualified service personnel.

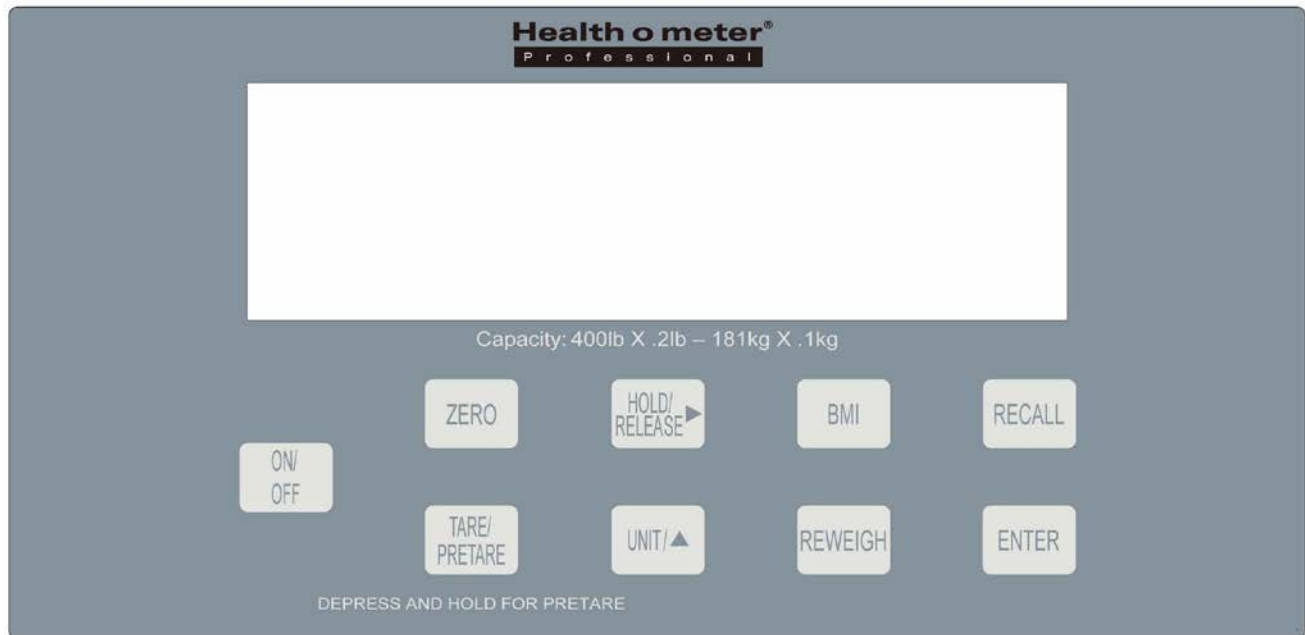

Figure 14 - Keypad

Function	Description
ON/OFF	Turns scale on and off.
ZERO	Zeros the scale prior to a weighing.
HOLD/RELEASE ▶	Holds the weight value of the patient on the display until the button is pressed again to clear the value. Also moves the cursor from left to right on the display for entering height and pretare value.
BMI	Prompts entry of height data to calculate patient's Body Mass Index (BMI).
RECALL	Recalls the previous weight.
TARE/PRETARE	TARE-Tares out weight of an object on the platform. PRETARE-Prompts entry of a tare value that will be deducted from the weight on the platform. Also releases tare weight (returns display to zero).
UNIT/▲	Toggles between pounds and kilograms. Also used to increment height value and pretare value.
REWEIGH	Allows repeated weighing of the patient without stepping off the scale.
ENTER	Used to accept height value in BMI mode, and tare value in PRETARE mode. Also releases the recall value and BMI value.

OPERATING INSTRUCTIONS (CONT)

Tare Function

When using this scale, the weight of an object, such as the stretcher, can be subtracted from the total weight in order to determine the weight of the patient alone. The Tare Function automatically performs this subtraction. The 2000KL scales allow tare weight to be entered manually by using the keypad, or automatically, as outlined in this section.

Tare

1. With all weight off the scale, press the **ON/OFF** button to turn on the scale.
2. Wait until the "0.0" LB or "0.0" KG appears on the display.
3. Hook the stretcher onto the scale. The display will show a value for the stretcher's weight.
4. Press the **TARE** button. The scale will zero out, and the word "TARE" will appear at the bottom center of the display, indicating that there is a tare value for the stretcher.
5. Remove the stretcher from the scale. Once the stretcher is removed from the scale, the display will show a negative weight, equal to the weight of the stretcher.
6. Hook the stretcher onto the scale and place the patient onto the stretcher. The scale will automatically deduct the tare weight of the stretcher from the gross weight of the patient and object together.
7. The weight of the patient will appear on the scale.
8. With no weight on the scale, the tare value will remain on the display until changed, cleared, or until the scale is turned off.
9. To remove the Tare, press the **TARE** button again. The word "TARE" will disappear from the bottom of the display, and the tare value will be cleared from the display. The scale will resume normal operation.

Pre (Limit 80.0 lb)

1. Make sure that there is no object on the stretcher and that the stretcher is unhooked from the scale.
2. Press the **ON/OFF** button to turn on the scale.
3. Wait until the "0.0" LB or "0.0" KG and "ZERO" appear on the display.
4. Hold down the **TARE** button for 3 to 5 seconds. The word "TARE" will appear at the bottom center of the display, and the user will be prompted to enter the tare value.
5. Use the keypad **▶** and **▲** buttons to enter the weight of the stretcher. Press the **ENTER** button.
6. The value entered will show as a negative value on the display.
7. Hook the stretcher onto the scale and place the patient onto the stretcher. The scale will automatically deduct the tare weight as entered, from the gross weight of the patient and the object.

OPERATING INSTRUCTIONS (CONT)

8. The weight of the patient will appear on the scale.
9. With no weight on the scale, the tare value will remain on the display until changed, cleared, or until the scale is turned off.
10. To remove the Tare, press the **TARE** button again. The word "TARE" will disappear from the display and the tare value will be cleared from the display. The scale will resume normal operation.

Placing the Patient on the Stretcher

Lay the stretcher on a bed or any other flat, stable surface you wish to use to transfer the patient onto the stretcher, and then perform the following steps:

1. Place the patient onto the stretcher.

Note: The patient's center mass should be placed as close as possible to the center of the stretcher.

2. Wheel the lifter scale close to the stretcher, and then lower the boom hoops to within 5-10 inches (12-25cm) of the patient's body.

3. Connect the hanging loops of the stretcher to the hooks at the end of each set of stretcher hoops, making sure the loops hang properly and equally from the hooks.

Note: Make sure the stretcher hanging hoops / are properly attached to the end of the hooks at the stretcher hoops. If not, an inaccurate reading could result.

4. Tighten the hydraulic control valve knob by turning it clockwise. The control valve knob is located on the pump near the pump handle.

5. Use the Base Adjustment Lever to widen the lifter base. The base must be spread to the widest possible position to maximize the scale stability when lifting the patient.

6. **SLOWLY** pump the hydraulic pump handle to lift the stretcher and patient until the entire stretcher is hanging from the loops and is not touching any surface below or any object around it. Do not lock the wheels on the lifter base. If needed, the base will move slightly or adjust for balance.

Caution: Never transport patient while on scale; never leave a patient unattended while he or she is on the scale.

Weighing a Patient

Note: When this scale is turned on, it will always default to the settings and units last used (lb or kg).

1. Make sure there is no object on the stretcher.
2. Press the **ON/OFF** button to turn the scale on.
3. Wait until the "0.0" LB or "0.0" KG appears on the display.
4. The scale will begin to display weight information and will lock on the patient's weight when the stable weight of the patient is determined. Depending on the movement of the patient on the scale, it may take several seconds for the scale to lock onto the weight.

OPERATING INSTRUCTIONS (CONT)

5. The weight may be held on the display by pressing the **HOLD/RELEASE** button. To release, press the **HOLD/RELEASE** button again.
6. After the weight measurement has been taken and is recorded, lower the stretcher and patient slowly back to their bed or other flat, stable surface by opening the hydraulic pump control valve by turning the knob counterclockwise VERY slowly, to control the descent.
7. Guide the patient on the stretcher carefully down to the bed or flat, stable surface.
8. Release the hanging loops from the stretcher hoops, once the patient is resting on the bed.
9. Press the **ON/OFF** button to turn the scale off.

Weight Recall

The last weight reading on the scale can be recalled by pressing the **RECALL** button. To clear the display of the recalled weight, press the **ENTER** button.

Note: Clearing the recalled weight from the display will not clear the recalled weight from memory. The recalled weight will remain in memory until another weight is obtained.

BMI Function

Note: The scale will not calculate BMI for a patient that is 24 pounds (12 kg) or less. If a height is not entered for the patient within 30 seconds of pressing the **BMI** button, the scale will return to the normal weighing mode.

1. Make sure there is no object on the stretcher.
2. Press the **ON/OFF** button to turn the scale on.
3. Wait until the "0.0" LB or "0.0" KG appears on the display.
4. Place the patient onto the stretcher. The scale will begin to display weight information and will lock on the patient's weight when the stable weight of the patient is determined. Depending on the movement of the patient on the scale, it may take several seconds for the scale to lock onto the weight.
5. Once a weight has been displayed, while the patient is still on the scale, Health o meter recommends performing a second weighing by pressing the **REWEIGH** button.
6. After obtaining the patient's weight on the scale, press the **BMI** button while the scale is on.
7. The scale will prompt you to enter the patient's height. Use the keypad **▲** and **▶** buttons to enter the patient's height.

Note: When weighing in pounds, the height is displayed in inches. When weighing in kilograms, the height is displayed in centimeter.

8. Once height is keyed in, press the **ENTER** button.
9. The display will show the patient's BMI.
10. Press **ENTER** to return to the normal weighing mode of the scale.

MAINTENANCE

Maintenance

The following pages provide instructions for maintenance, cleaning, calibration, and troubleshooting for the 2000KL scale. Maintenance operations other than those described in this manual should be performed by qualified service personnel.

Caution: Before first use, or after long periods of non-use, check the scale for proper operation and function. If the scale does not operate correctly, refer to qualified service personnel.

1. Check overall appearance of the total scale for any obvious damage, wear, and tear.
2. Inspect the AC adapter for cord cracking or fraying, or for broken/bent prongs.

Note: This scale is an extremely sensitive weighing device. If the auto-off function is disabled, battery power will be consumed.

Cleaning

Proper care and cleaning is essential to ensure a long life of accurate and effective operation.

Caution: Disconnect the scale from the AC adapter power source prior to cleaning the unit.

1. Clean all external surfaces with a clean damp cloth or tissue. Mild antimicrobial or antibacterial soap and water solution may be used. Dry with a clean soft cloth.
2. Do not immerse the scale into cleaning or other liquid solutions.
3. Do not use Isopropyl Alcohol or other solutions to clean the display surface.
4. Do not use abrasive cleaners.

CALIBRATION

Calibration

This scale has been factory calibrated, and does not require calibration prior to use. For maintenance, the scale can be calibrated. Calibration of your 2000KL scale is performed using kilograms (kg) or pounds (lb), according to the units of measure used upon entering into the calibration path. The following calibration assumes the scale is set to pounds, and 400 lb (the default weight) is employed as the calibration weight.

Note: Only weights certified and traceable to national standards are to be used for calibration.

Scale Calibration

Operator Action	Display
1. Make sure the display is turned off, then press and hold the HOLD/RELEASE button while pressing the ON/OFF button. (Two alphanumeric characters will appear next to U followed by 4-5 characters.)	U“XX” followed by a 4-5 digit ‘idle scale count’ number.
2. Press the ENTER button.	“CAL”.
3. Make sure there is nothing on the scale, then press the ENTER button again.	“Clear” followed by “0400.0LB”.
4. Use the ► and ▲ buttons to set the calibration weight to a value other than the default weight. The calibration weight should be as high as possible, with 200 lb as a minimum calibration weight.	Shows “400.0” or entered calibration weight.
5. Press the ENTER button.	Alternating “Load” followed by “400.0LB”.
6. Load the scale with the required weight.	Display increments showing raw weight data.
7. Without touching or shaking the scale, allow the display to stabilize, then press the ENTER button.	“SUCC” or “Err1”.
8. If the calibration is successful, the display will show SUCC and turn off. If the calibration is not successful, the display will show Err1 and turn off. Contact customer service for an Err1 display (+1 800-638-3722).	-----

TROUBLESHOOTING

Troubleshooting

Before contacting service personnel, refer to the following instructions to check and to correct any failures.

Symptom	Possible Cause	Corrective Action
Scale does not turn on	<ol style="list-style-type: none">1. Dead battery2. Faulty electrical outlet3. Bad power supply	<ol style="list-style-type: none">1. Replace batteries2. Use a different outlet3. Replace AC adapter
Questionable weight or the scale does not zero	<ol style="list-style-type: none">1. External object interfering with the scale2. Scale is out of calibration3. Improper Tare	<ol style="list-style-type: none">1. Remove interfering object from the stretcher assembly2. Check weight with known weight value3. see "Automatic (push button tare)" page 21
Weighing is performed but the weighing process takes too long and the weight does not lock on the displayed	The patient is not laying still	Ask the patient to lay still
The display shows "Over" message	The load on the scale exceeds the capacity (400 lb / 181 kg)	Remove the excess weight and use the scale according to its limits
The display shows "Lo bAtt" message	The batteries are depleted	Replace batteries according to instructions

WARRANTY

Limited Warranty

What does the Warranty Cover?

This Health o meter® Professional scale is warranted from date of purchase against defects of materials or in workmanship for a period of two (2) years. If product fails to function properly, return the product, freight prepaid and properly packed to Pelstar, LLC (see "To Get Warranty Service", below, for instructions). If the manufacturer determines that a defect of material or in workmanship exists, the customer's sole remedy will be replacement of the scale at no charge. Replacement will be made with a new or remanufactured product or component. If the product is no longer available, replacement may be made with a similar product of equal or greater value. All replaced parts are covered only for the original warranty period.

Who is Covered?

The original purchaser of the product must have proof of purchase to receive warranty service. Please save your invoice or receipt. Pelstar dealers or retail stores selling Pelstar products do not have the right to alter, or modify or any way change the terms and conditions of this warranty.

What is Excluded?

Your warranty does not cover normal wear of parts or damage resulting from any of the following: negligent use or misuse of the product, use on improper voltage or current, use contrary to the operating instructions, abuse including tampering, damage in transit, or unauthorized repair or alternations. Further, the warranty does not cover natural disasters, such as fire, flood, hurricanes and tornadoes. This warranty gives you specific legal rights, and you may also have other rights that vary from country to country, state to state, province to province or jurisdiction to jurisdiction.

To get Warranty Service make sure you keep your sales receipt or document showing proof of purchase. Call (+1) 800-638-3722 or (+1) 708-377-0600 to receive a return authorization (RA) number, which must be included on the return label. Attach your proof of purchase to your defective product along with your name, address, daytime telephone number and description of the problem. Carefully package the product and send with shipping and insurance prepaid to:

Pelstar, LLC
Attention R/A# _____
Return Department
9500 West 55th Street
McCook, IL 60525



PELSTAR, LLC

9500 West 55th Street • McCook, IL 60525 • USA

1-800-638-3722 or 1-708-377-0600

PLEASE REGISTER YOUR SCALE FOR WARRANTY COVERAGE AT:

www.homscalas.com

Health o meter® is a registered trademark of Sunbeam Products, Inc. used under license.

Health o meter® Professional products are manufactured, designed, and owned by Pelstar, LLC.

We reserve the right to improve, enhance, or modify Health o meter® Professional product features or specifications without notice.

© Pelstar, LLC 2017



P/N UM2000KL Rev20170306