



FAMILY PRACTICE & CABINET STYLE TABLES

MODELS: 8834, 8844, 8870 & 8890



ASSEMBLY INSTRUCTIONS

ASSEMBLY INSTRUCTIONS FOR FAMILY PRACTICE EXAM TABLES

MODELS: 8834, 8844, 8870 & 8890

MAXIMUM WEIGHT CAPACITY 400 LBS

Thank you for counting on Clinton to meet your medical equipment needs by purchasing this fine equipment. All Clinton equipment is designed and manufactured to provide years of dependable service because we want you as a customer now and in the future. Below are easy to follow instructions on how to properly assemble your equipment. Please contact us at 800-441-9131 if you experience any difficulty with the assembly or have questions.

INTENDED USE. Clinton Family Practice and Space Saver models 8834, 8844, 8870 and 8890 are specifically designed and engineered for medical examinations use only. Persons using the table should be observed by trained medical personnel while on the table and getting off the table. Never leave anyone unattended on the table. Combination of weight and force exerted on the table is not to exceed a total of 400 lbs. Using this equipment for unintended purposes could result in damage to the equipment and serious injury.

CAUTION: Never sit on the pull-out leg rest or the head end of the table. The pull-out leg rest and the head end of the table are not engineered to support full body weight or excessive weight/force combination. Sitting on the leg rest and/or head end of the table could result in damage to the table and/or serious injury.

WARNING: Periodically check that both of the pull-out, step stool's rubber feet are in good condition, and rest on the floor when in use. If not, serious damage to the table, as well as, serious injury could occur to persons using the step stool which could slip while in use.

MODEL 8870

MODEL 8834 same as 8870 without stirrups



MODEL 8890

MODEL 8844 same as 8890 without stirrups

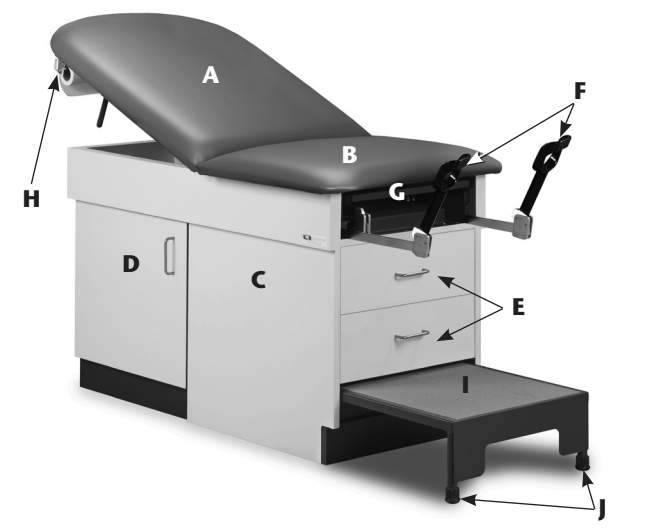

Contents

- A. Adjustable Padded Backrest
- B. Padded seat
- C. Base
- D. Dual Entry Storage
- E. Drawer Storage
- F. Pull-Out Stirrups (8870 only)
- G. Laminate Pull-Out
- H. Paper Dispenser

Hardware for Table

- (4) 1" Hex Head Bolts
- (8) 3/4" Pan Head Screws
- (4) 7/16" Kep® Lock Nuts
- (4) 1/4" washers

Tools Required

- Phillips Screwdriver/Screw Gun
- Socket Wrench

Time Required

- 15–20 Minutes

Contents

- A. Adjustable Padded Backrest
- B. Padded seat
- C. Base
- D. Dual Entry Storage
- E. Drawer Storage
- F. Pull-Out Stirrups
- G. Laminate Pull-Out
- H. Paper Dispenser
- I. Pull-Out Step Stool
- J. Rubber Feet

Hardware for Table

- (4) 1" Hex Head Bolts
- (8) 3/4" Pan Head Screws
- (4) 7/16" Kep® Lock Nuts
- (4) 1/4" washers

Tools Required

- Phillips Screwdriver/Screw Gun
- Socket Wrench

Time Required

- 15–20 Minutes

1 Attach backrest to the table by lining up holes in hinge with the 4 protruding bolts in the center table brace. Secure the backrest with the (4) four Kep® Lock Nuts and a 7/16" socket wrench.

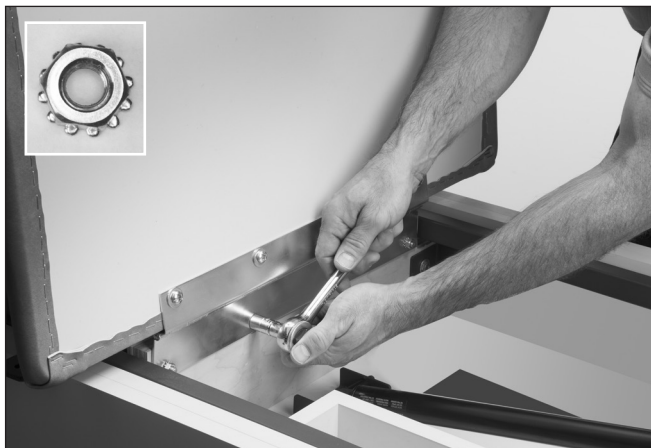

2 Extend the pneumatic cylinder about half way by holding the apparatus with one hand and pressing down on one of the levers with the other.



3 Secure the pneumatic cylinder's bracket to the backrest with the (8) eight 3/4" pan head screws.

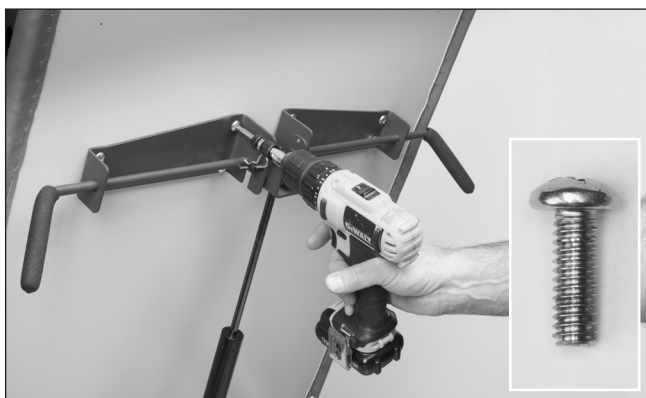

4 Locate the seat brackets and place padded seat on top of the brackets.

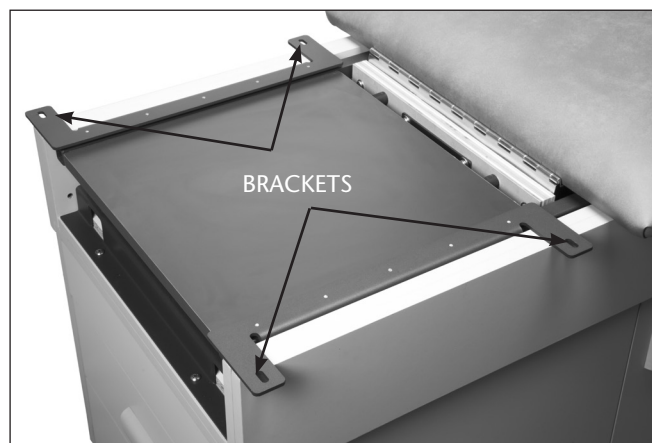

5 Secure the seat to the seat brackets using (4) four 1" hex head bolts and 1/4" washers. **DO NOT TIGHTEN ALL THE WAY.**

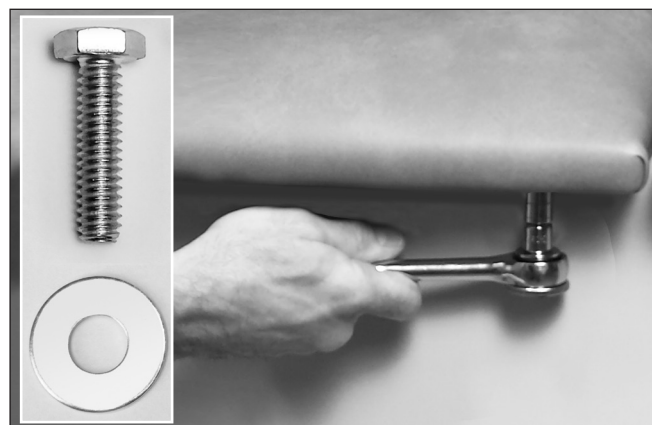

6 Check the alignment of the seat in relationship to the backrest, slide the seat side to side to adjust if necessary.

When satisfied with the alignment, tighten the bolts from step 5 all the way, making sure the seat is in a fixed and secure position.



7

Door and drawer pulls are packed in one of the drawers. Position the pulls and screw into place.



8

PAPER DISPENSER.

Place rod through paper tube and place onto brackets. Metal caps should be on the outside of the brackets.



FOR SAFETY PURPOSES, TAKE TIME TO CHECK ALL FASTENERS TO INSURE THAT THEY ARE SECURELY TIGHTENED AND THAT THE EQUIPMENT HAS BEEN PROPERLY ASSEMBLED ACCORDING TO THESE INSTRUCTIONS.

Warranty

Clinton Industries warrants manufactured products to be free of defects in materials, workmanship or design under normal use for five years on all products, from the date of purchase. This warranty does not include damage resulting from accident, abuse or misuse, alteration, or negligence of the product and expressly excludes normal wear of parts (including but not limited to vinyl). Contact Clinton for full warranty details.



Care & Cleaning

Clinton products are built to be durable. With proper care, your Clinton equipment will provide years of superior looks and performance. Before using any cleaning agents, try them on a small inconspicuous area to insure that they will not harm the any surface. Damage from cleaning is not covered under the warranty.

Do not use alcohol based cleaning agents. Periodically check that all fasteners are secure and operating properly.



800-441-9131 • 717-848-3519
Toll-Free Fax 866-522-1233 • Fax 717-843-5871
www.clinton-ind.com

