



Wireless Remote Controller AL-60-03-0002



This Wireless Remote Control and Wireless Receiver (sold separately) work together to provide mode, color, brightness, and zone control for both Radialux RGB and RGB-W tape lights. The controller can operate up to four independent zones, so you can have different color-changing effects in different rooms or parts of a space. The remote can save up to three custom colors or modes. A touch wheel allows for direct visual selection of colors.

Specifications

- Operation Voltage: 4.5V DC
- Zones: 4
- Signal: WIFI / RF
- Location: Dry (IP20)
- Compatible Receiver: Wireless Receiver A-60-03-0004



Wiring Diagram

1) Receiver Connection Diagram for Single Unit

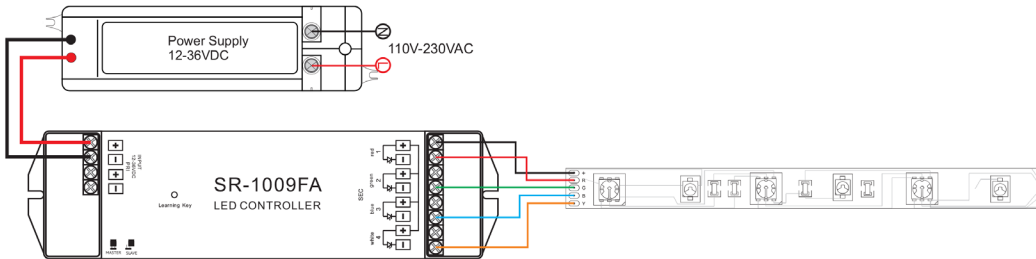

2) Receiver Connection Diagram for Multiple Units

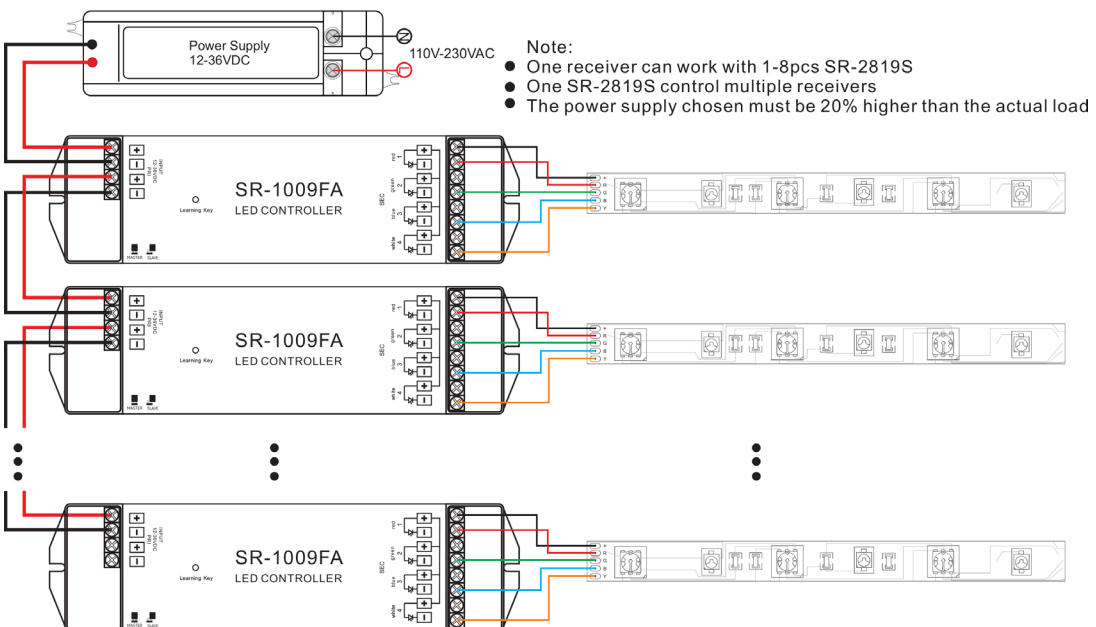

Keypad Layout

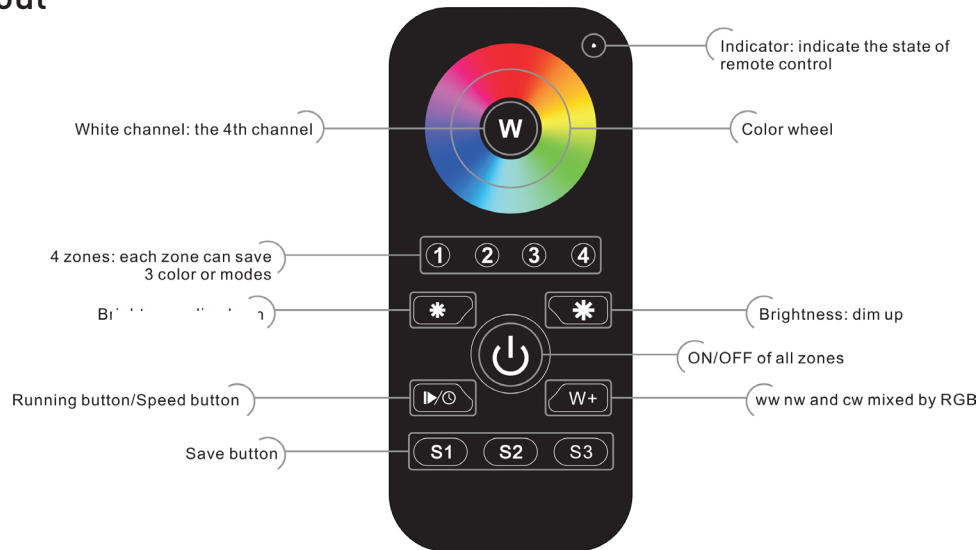

Operation

How to Configure:

- Do wiring according to connection diagram
- Wake up the remote control by touching ON/OFF button.
- Press learning button on receiver.
- Touch any zone button on remote control.
- Then touch color wheel.
- Connected LED light will blink to confirm zone designation.
- Press at learning button on receiver over 5 seconds until LED light flashes, then delete the learned ID.

Note 1: To choose a master from slaves by jumper for each zone. Short circuit for master. Open circuit for slave.

Each zone only can set one master controller. After a period of time, the master will do synchronization operation to keep the same color or mode of all slaves in one zone.

Note 2: Each remote control 4 zones (areas) receivers, each area can be learned as many receivers as we can.

Each receiver maximally can be controlled by 8 different remote controllers.

Color Wheel

Choose zone number 1, 2, 3, or 4, for example 1, and 3, then touch color wheel, choose the color you want, zone 1 and 3 will indicate corresponding color as touched.

Brightness Up & Down Button

Short/Long press Brightness Button to dim down/up brightness, the dimming direction will change every time after pressing switch. For example, the first long press is brightness up, it will be dimmed down when long press again.

Running Mode /Speed Button

1. Short press Running Button/Speed Button, mode will run. Press it once, it runs one mode. Press button again, it stops, then press one more time, it will enter next mode. There are total 10 built-in modes.
2. Long press Running Button/Speed Button when mode is running, first long press will speed up the color moving, long press again to speed down the color moving.

W+ Button

1. RGB channel will mix to three different white: warm white, nature white and cold white by short press of W+ Button. For example: first press → warm white, press again → nature white, third press again → cold white, fourth press → warm white, etc.
2. Fast click W+ Button twice to switch off RGB channel.

Save and recall button

1. Save color: select zones from 1, 2, 3, 4 buttons → select color from Color Wheel → long press one save button from S1, S2, S3 for 2-3 seconds → LED light flashes twice indicates successful save.
2. Save running mode: select from zones 1, 2, 3, 4 → select a moving mode from Running Mode/Speed Button → long press save button from S1, S2, S3 for 2-3 seconds.
3. Recall: select zone button which we want recall from 1, 2, 3, 4 buttons, then short press save button S1, S2, S3.