

Temperature Control Panel Wiring Diagram

Model: IFPA-208-IP-35A

Shift Controls, Inc.

Installed Options:
 None

www.shift-controls.com
 support@shift-controls.com
 720.532.1776

Temperature Control Panel Specifications

Model Number	IFPA-208-IP-35A
Rated Voltage	208 VAC
Phases	Single
Power Controller	Zero Crossing SCR
Rated Frequency	60 Hz
SCCR	100 kA
Control Voltage	208 VAC
Maximum Fuse Size	45 Amps, Class J, High Speed
Maximum Full Load Current	35 Amps, Resistive
Maximum Load	7.28 kW
Enclosure Type	Nema 4X
Operating Environment	0 - 35 deg C, 10-85% RH, Non-Condensing, Indoor Use Only

REV.	DATE	DRAWN BY	DESCRIPTION
A	03/14/16	B. KETTLER	FOR CONSTRUCTION
DRAWING TYPE WIRING SCHEMATIC			

DRAWING DESCRIPTION CONTROL PANEL SPECIFICATIONS AND WIRE COLOR STANDARDS

DRAWING NUMBER E-IFPA-208-IP-35A
SHEET NUMBER SHEET i



Fuse Replacement Voltage, Amperage, Class and Type Reference

FUSE REPLACEMENT NOTES:

1) Fuses are to be replaced with fuses of the same voltage rating, current rating, and fuse type.

Fuse Name	Description	Voltage Rating	Maximum Value	Fuse Type		Manufacturer Equivalent		
						Edison	Bussmann	Littelfuse
F1, F2	Main Power Branch Fusing	600	45 Amps	Class J	High Speed	JHL	DFJ	N/A
F3, F4	Control Circuit Supply Fusing	250	1 Amp	5x20mm	Fast-Acting	GMA	GMA	235

Main Branch Fuse Protection (F1, F2) Ampacity Reference Table

FUSE SIZING NOTES:

1) The maximum resistive heater load is 35 Amps / 7.28 kW at 208 VAC 1-Phase.

2) Fuses are to be sized 125-165% of the heater full load.

Heater Full Load Rating		Fuse Size, Current Rating										
		Littlefuse ® LRUJ63 Fuse Reducers Required for 1-30A Fuses									No Fuse Reducers Required	
		8A	10A	12A	15A	17.5A	20A	25A	30A	35A	40A	45A
Full Load Power, kW	Minimum	1.01	1.26	1.51	1.89	2.21	2.52	3.15	3.78	4.41	5.04	5.67
Full Load Power, kW	Maximum	1.33	1.66	2.00	2.50	2.91	3.33	4.16	4.99	5.82	6.66	7.28
Full Load Current, Amps	Minimum	4.85	6.06	7.27	9.09	10.6	12.1	15.2	18.2	21.2	24.2	27.3
Full Load Current, Amps	Maximum	6.40	8.00	9.60	12.0	14.0	16.0	20.0	24.0	28.0	32.0	35.0

REV.	DATE	DRAWN BY	DESCRIPTION
A	03/14/16	B. KETTLER	FOR CONSTRUCTION

DRAWING TYPE: WIRING SCHEMATIC

DRAWING DESCRIPTION: FUSE AND FIELD WIRING SPECIFICATIONS

DRAWING NUMBER: E-IFPA-208-IP-35A
 SHEET NUMBER: SHEET ii



Standard Wire Colors	
208VAC, 1-Phase Power	Black (BK), Red (RD)
Ground Wires	Green (GN)
AC Control Power, 208VAC Ungrounded AC	Black (BK)
Thermocouple Cable	Type K - Yellow Cable, Type J - Black Cable
DC Signal wires	2-Conductor Cable
RS-485, Data	2-Conductor Cable

Customer Supplied Wire Size, Rating and Terminal Tightening Torque Reference

NOTES:
 1) Conductor Sizing to be Determined by NEC and Local Codes
 2) Control wiring (Terminals 93-98) to be Class II unless customer supplied circuits to Alarm I (Terminals 91, 92) are greater than 150 Volts. If customer supplied wiring is greater than 150 Volts, then all control wiring (Terminals 91-98) are to be Class I.

Terminal Number	Description	Wire					Tightening Torque	
		Conductor Material	Minimum Voltage Rating	Minimum Temp. Rating	Minimum Wire Size	Maximum Wire Size	Minimum	Maximum
1, 2, 3	Main Power Line (L1, L2, GND)	Copper	300 VAC	75 C	14AWG, 1.6mm See Note 1	6AWG, 4.1mm See Note 1	13.3 in*lb, 1.5 N*m	15.9 in*lb, 1.8 N*m
4, 5, 6	Heater Power Load (T1, T2, GND)	Copper	300 VAC	75 C	14AWG, 1.6mm See Note 1	6AWG, 4.1mm See Note 1	13.3 in*lb, 1.5 N*m	15.9 in*lb, 1.8 N*m
91, 92	User Programable Alarm (Dry Contacts)	Copper	Class I	60 C	26AWG, 0.4mm See Note 1	10AWG, 2.5mm See Note 1	5.3 in*lb, 0.6 N*m	7.0 in*lb, 0.8 N*m
93, 94	Temp. Retransmit (4-20mA Sourcing)	Copper	Class II See Note 2	60 C	26AWG, 0.4mm See Note 1	10AWG, 2.5mm See Note 1	5.3 in*lb, 0.6 N*m	7.0 in*lb, 0.8 N*m
95, 96	RS-485 Modbus Communication	Copper	Class II See Note 2	60 C	26AWG, 0.4mm See Note 1	10AWG, 2.5mm See Note 1	5.3 in*lb, 0.6 N*m	7.0 in*lb, 0.8 N*m
97, 98	Thermocouple Input	TC Wire	Class II See Note 2	60 C	24AWG	14AWG Solid 16AWG Stranded	3.5 in*lb, 0.4 N*m	3.5 in*lb, 0.4 N*m
A1, A2	External Interlock (Option)	Copper	Class I	60 C	26AWG, 0.4mm See Note 1	14AWG, 1.6mm See Note 1	3.5 in*lb, 0.4 N*m	3.5 in*lb, 0.4 N*m

Wiring Schematic Typical Symbols and Standards

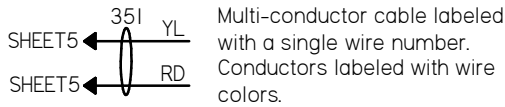
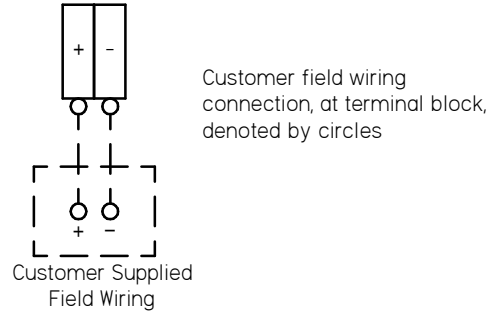
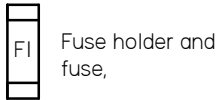
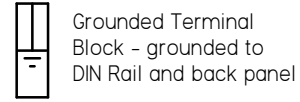
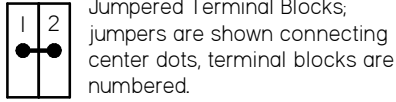

--- Customer supplied, field wiring

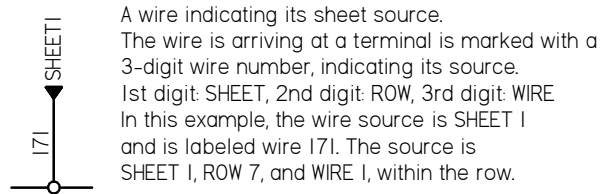
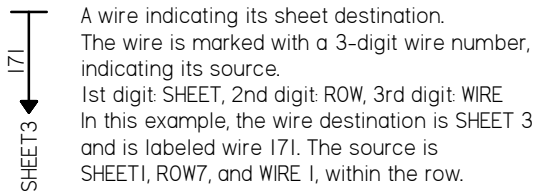
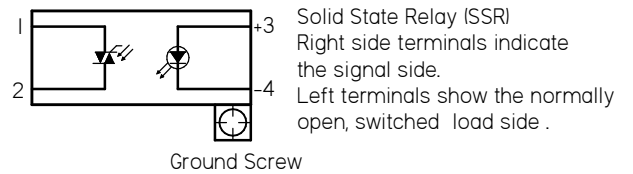
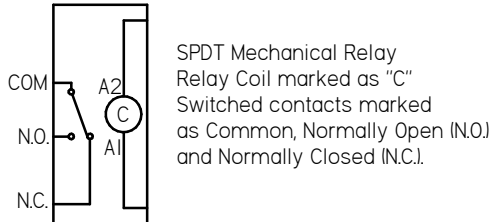

170

REV.	DATE	DRAWN BY	DESCRIPTION	DRAWING DESCRIPTION	DRAWING NUMBER
A	03/14/16	B. KETTLER	FOR CONSTRUCTION	TYPICAL SYMBOLS, STANDARDS and WIRE LABELING CONVENTIONS	E-IFPA-208-IP-35A
DRAWING TYPE					SHEET NUMBER
WIRING SCHEMATIC					SHEET iv



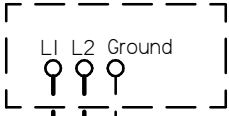
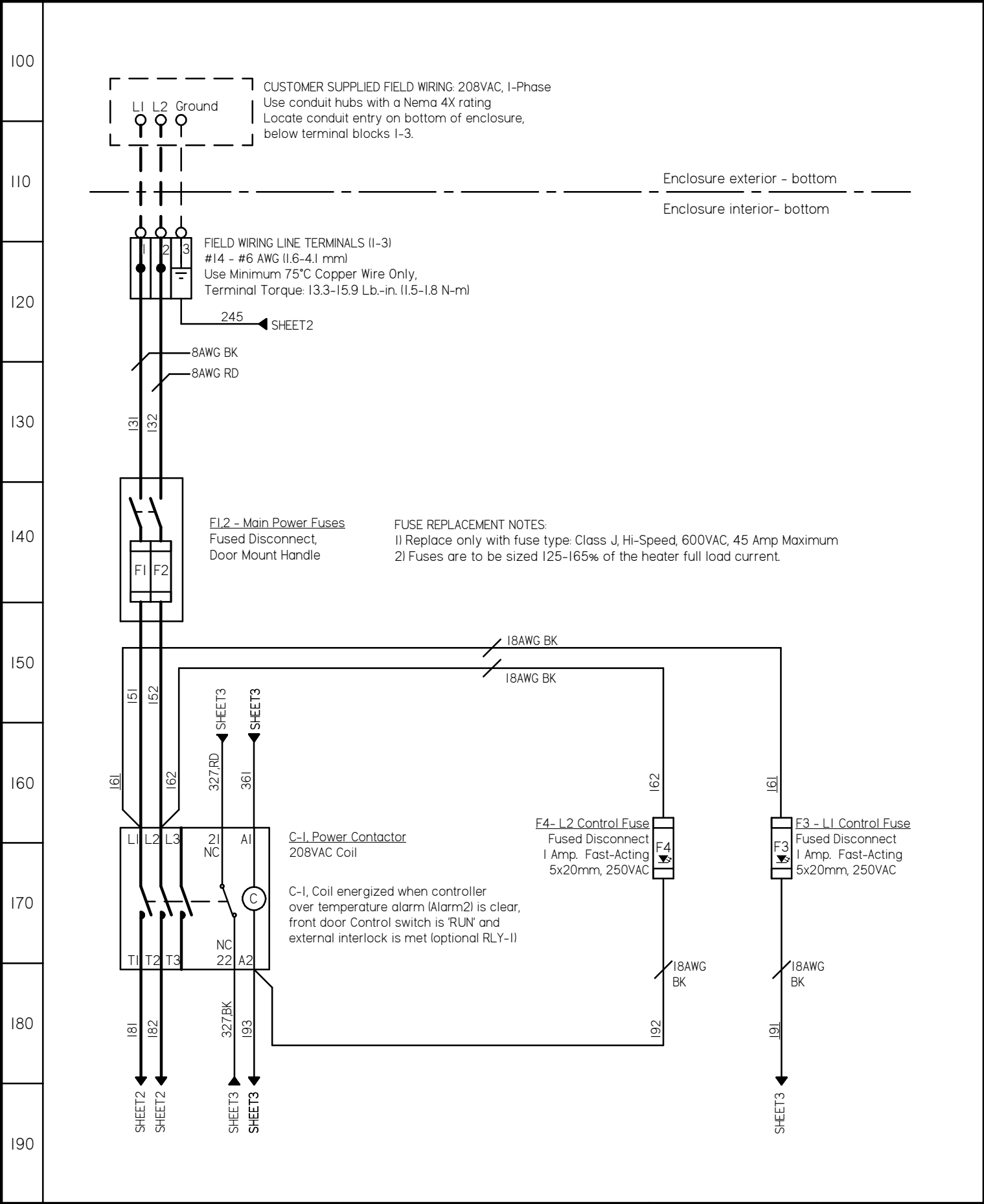

CUSTOMER SUPPLIED FIELD WIRING: 208VAC, 1-Phase
 Use conduit hubs with a Nema 4X rating
 Locate conduit entry on bottom of enclosure,
 below terminal blocks 1-3.

Enclosure exterior - bottom

Enclosure interior- bottom

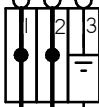

FIELD WIRING LINE TERMINALS (I-3)
 #14 - #6 AWG (1.6-4.1 mm)
 Use Minimum 75°C Copper Wire Only,
 Terminal Torque: 13.3-15.9 Lb.-in. (1.5-1.8 N-m)

245 SHEET2

8AWG BK
 8AWG RD

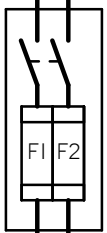

F1,2 - Main Power Fuses
 Fused Disconnect,
 Door Mount Handle

FUSE REPLACEMENT NOTES:
 1) Replace only with fuse type: Class J, Hi-Speed, 600VAC, 45 Amp Maximum
 2) Fuses are to be sized 125-165% of the heater full load current.

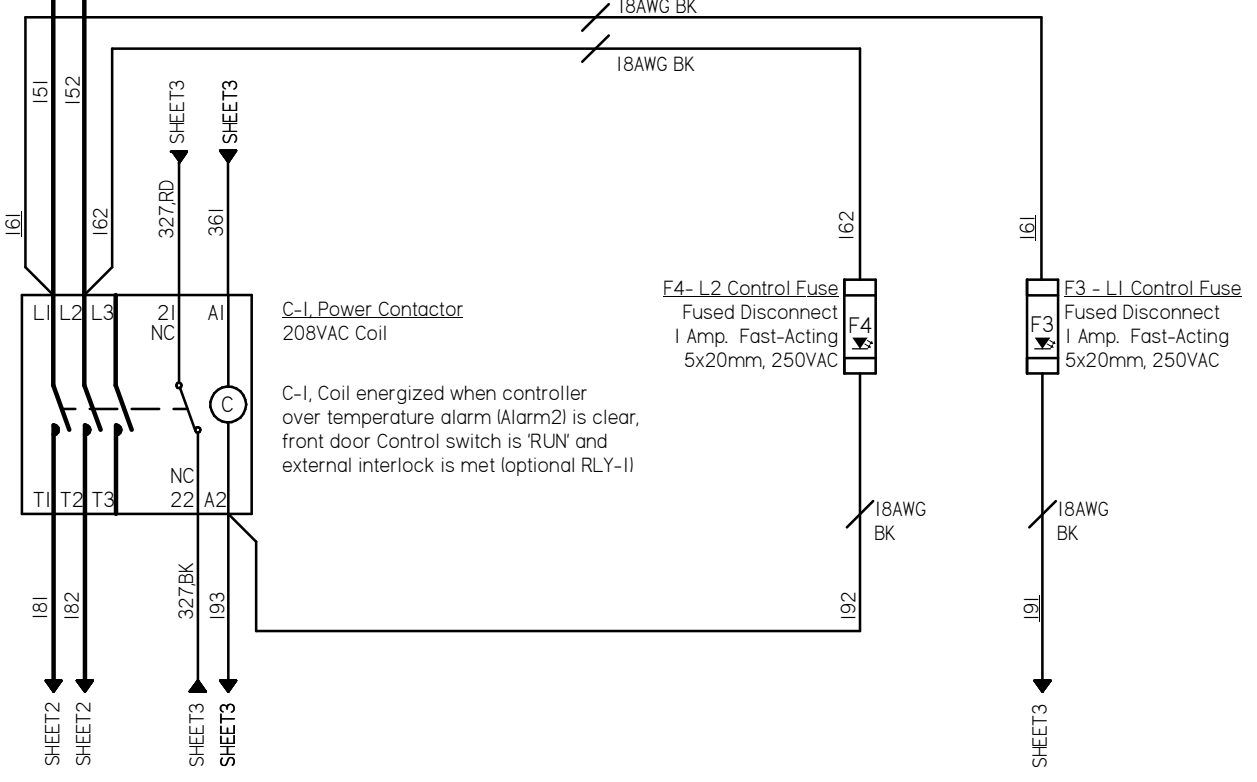

C-1, Power Contactor
 208VAC Coil

C-1, Coil energized when controller
 over temperature alarm (Alarm2) is clear,
 front door Control switch is 'RUN' and
 external interlock is met (optional RLY-1)

F4- L2 Control Fuse
 Fused Disconnect
 1 Amp. Fast-Acting
 5x20mm, 250VAC

F3 - L1 Control Fuse
 Fused Disconnect
 1 Amp. Fast-Acting
 5x20mm, 250VAC

REV.	DATE	DRAWN BY	DESCRIPTION
A	03/14/16	B. KETTLER	FOR CONSTRUCTION

DRAWING TYPE: WIRING SCHEMATIC

DRAWING DESCRIPTION: FUSED DISCONNECT, CONTACTOR, AND CONTROL TRANSFORMER

DRAWING NUMBER: E-IFPA-208-IP-35A
 SHEET NUMBER: SHEET 1 of 4



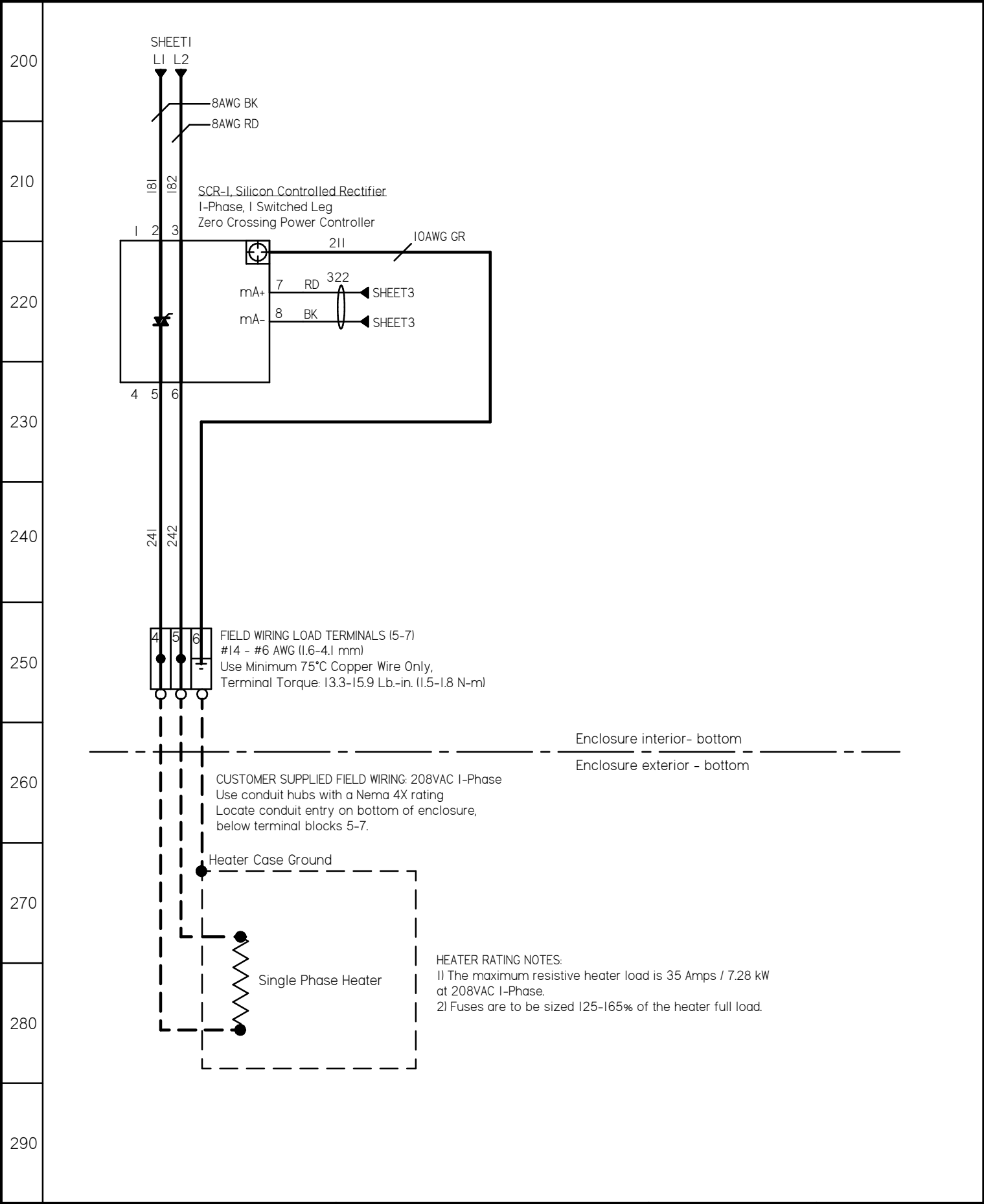

REV.	DATE	DRAWN BY	DESCRIPTION
A	03/14/16	B. KETTLER	FOR CONSTRUCTION

DRAWING TYPE: WIRING SCHEMATIC

DRAWING DESCRIPTION: POWER CONTROLLER AND ENCLOSURE COOLING

DRAWING NUMBER: E-IFPA-208-IP-35A
SHEET NUMBER: SHEET 2 OF 4



300
310
320
330
340
350
360
370
380
390

TIC-I, PID Temperature Controller
Door Mount

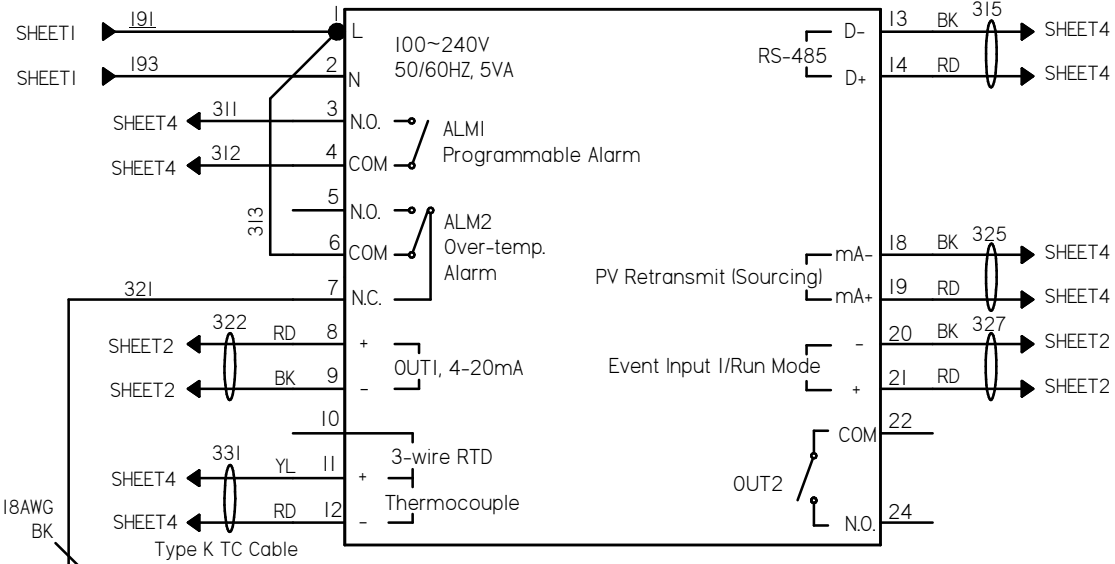

Note:
Type K thermocouple: YL is + and RD is -
Type J thermocouple: WH is + and RD is -

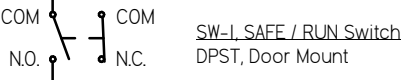

REV.	DATE	DRAWN BY	DESCRIPTION
A	03/14/16	B. KETTLER	FOR CONSTRUCTION

DRAWING TYPE: WIRING SCHEMATIC

DRAWING DESCRIPTION
TEMPERATURE CONTROLLER

DRAWING NUMBER
E-IFPA-208-IP-35A
SHEET NUMBER
SHEET 3 OF 4



400

410

420

430

440

450

460

470

480

490

FIELD CONTROL TERMINALS (91-96)
 #26 - #10 AWG (0.4-2.5 mm)
 Use Minimum 60°C Copper Wire Only,
 Terminal Torque: 5.4-7.0 Lb.-in. (0.6-0.8 N-m)

FIELD THERMOCOUPLE TERMINALS (97-98)
 #24 - #14 AWG (0.5-1.6 mm)
 Use Thermocouple Extension Wire Only,
 Terminal Torque: 3.5 Lb.-in. (0.4 N-m)

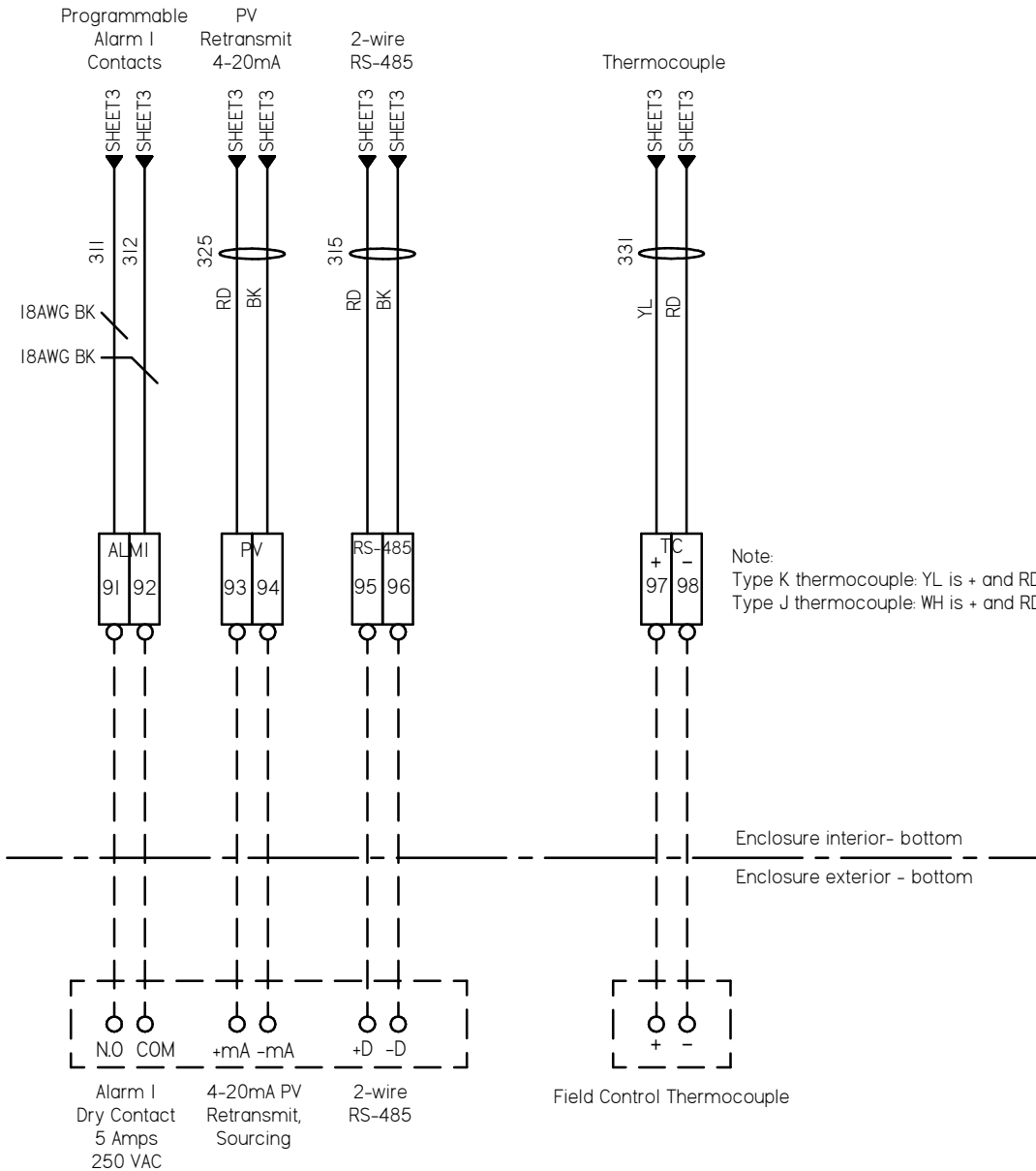

Note:
 Type K thermocouple: YL is + and RD is -
 Type J thermocouple: WH is + and RD is -

CUSTOMER SUPPLIED FIELD WIRING
 Use conduit hubs with a Nema 4X/12 rating.
 Locate conduit entry on bottom of enclosure,
 below terminal blocks 91-98.

NOTES:
 1) Conductor Sizing to be Determined by NEC and Local Codes
 2) Control wiring (Terminals 93-98) to be Class II unless customer supplied circuits to Alarm I (Terminals 91, 92) or optional Interlock (Terminals A1, A2) are greater than 150 Volts. If customer supplied wiring is greater than 150 Volts, then all control wiring (Terminals 91-98) are to be Class I.

REV.	DATE	DRAWN BY	DESCRIPTION
A	03/14/16	B. KETTLER	FOR CONSTRUCTION

DRAWING TYPE: WIRING SCHEMATIC

DRAWING DESCRIPTION

DRAWING NUMBER
E-IFPA-208-IP-35A
SHEET NUMBER
SHEET 4 OF 4

