

## BW CABLE GLAND

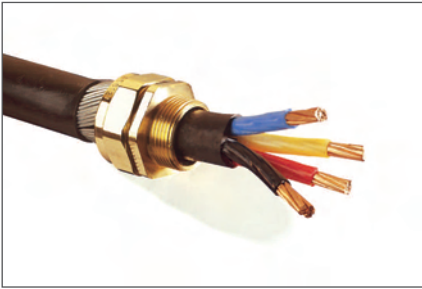

### BW Industrial Cable Gland

CMP BW type brass indoor cable gland for use with all types of Single Wire Armour (SWA) cable providing mechanical cable retention and electrical continuity via armour wire termination. The CMP BW range of industrial cable glands is designed and tested to BS6121:2005, and is produced from Brass grade CuZn39Pb3 (CW614N) to EN12168

#### TECHNICAL DATA

Type	BW
Design Specification	BS 6121: Part 1: 2005
GOST R Certificate Number	POCC GB. ГБ 05.H00110
GOST K Certificate Number	KZ7500052.05.01.00063
RoK Permit for Use Number	08-067693
Lloyds Approval Number	01/00171
ABS Approval Number	01-LD 234401-PDA
Standard Gland Material	Brass
Alternative Gland Material	Electroless Nickel Plated Brass, Stainless Steel, Aluminium
Cable Type	Single Wire Armour (SWA), Aluminium Wire Armour (AWA)
Armour Clamping	Two Part Armour Lock
Optional Accessories	Adaptor/Reducer, Earth Tag, Locknut, Serrated Washer, Shroud
Gland Kits Available	Cable Gland Kit for use with all types of SWA cable, including 2 Brass Glands, 2 Steel Locknuts, 2 Brass Earth Tags and 2 PVC Shrouds for sizes up to and including 32mm. For sizes 40mm and above each kit includes 1 of each component.

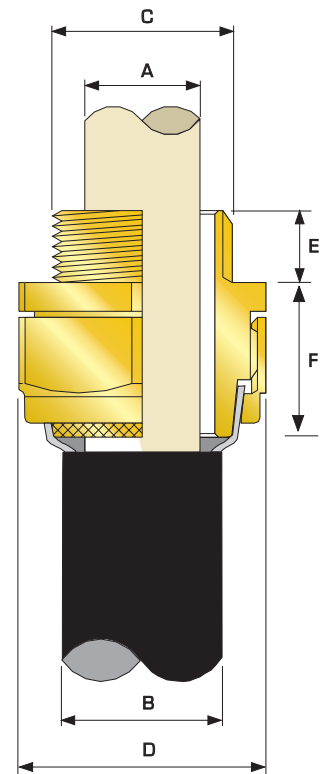

### Cable Gland Selection Table

Cable Gland Size	Entry Thread 'C'	Minimum Thread Length 'E'	Cable Bedding Diameter 'A'	Overall Cable Diameter 'B'	Armour Range		Across Flats 'D'	Across Corners 'D'	Nominal Protrusion Length 'F'	Ordering Reference (Brass Metric)	Shroud Reference*	Cable Gland Weight (Kgs)
			Max	Max	Min	Max	Max	Max				
20S	M20	10.0	11.7	16.1	0.8	1.25	22.0	24.2	18.0	20SBW1AA	PVC02	0.090
20	M20	10.0	14.0	21.1	0.8	1.25	28.0	30.8	22.0	20BW1AA	PVC05	0.100
25	M25	10.0	20.0	27.4	1.25	1.60	33.6	37.0	26.0	25BW1AA	PVC07	0.150
32	M32	10.0	26.3	34.4	1.6	2.00	41.0	45.1	28.0	32BW1AA	PVC10	0.200
40	M40	15.0	32.2	42.4	1.6	2.00	50.0	55.0	30.0	40BW1AA	PVC13	0.360
50S	M50	15.0	38.2	50.1	2.0	2.50	57.1	62.8	30.0	50SBW1AA	PVC16	0.480
50	M50	15.0	44.1	55.7	2.0	2.50	61.0	67.1	32.0	50BW1AA	PVC19	0.420
63S	M63	15.0	50.0	62.4	2.5	2.50	75.0	82.5	38.0	63SBW1AA	PVC22	0.800
63	M63	15.0	56.0	68.2	2.5	2.50	80.0	88.0	38.0	63BW1AA	PVC24	0.850
75S	M75	15.0	62.0	76.8	2.5	2.50	90.0	99.0	40.0	75SBW1AA	PVC27	1.300
75	M75	15.0	75.0	82.9	2.5	3.15	95.0	104.5	40.0	75BW1AA	PVC29	1.600

All dimensions in millimetres

Note: \*LSF Shrouds also available on request.