

دو کاب کونکت
Ducab Connect
MAKING CONNECTIONS

CONNECTING YOUR CABLES TO OUR WORLD



COMPRESSION TERMINALS
INDUSTRIAL CABLE GLANDS
CABLE CLEATING & FIXING SYSTEMS



INDUSTRIAL CABLE GLANDS

BW Industrial Cable Gland

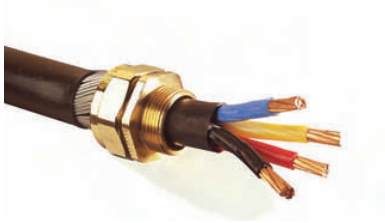

Ducab BW type brass indoor cable gland for use with all types of Single Wire Armour (SWA) cable providing mechanical cable retention and electrical continuity via armour wire termination. The Ducab BW range of industrial cable glands is designed and tested to BS 6121:2005, and is produced from Brass grade CuZn39Pb3 (CW614N) to EN 12168.

Note: Also available in LSdR kit form

Technical Data	
Type	BW
Design Specification	BS 6121:Part1:2005
SIRA Certificate Number	10Y9149U - BS 6121
GOST K Certificate Number	KZ7500052.05.01.00063
RoK Permit for Use Number	08-067693
Lloyds Approval Number	01/00171
ABS Approval Number	01-LD234401-PDA
Standard Gland Material	Brass
Alternative Gland Material	Electroless Nickel Plated Brass, Stainless Steel
Cable Type	Single Wire Armour (SWA), Aluminium Wire Armour (AWA)
Armour Clamping	Two Part Armour Lock
Optional Accessories	Adaptor/Reducer, Earth Tag, Locknut, Serrated Washer, Shroud
Gland Kits Available	Cable Gland Kit for use with all types of SWA cable, including 2 Brass Glands, 2 Locknuts, 2 Brass Earth Tags and 2 PVC Shrouds for sizes up to and including 32mm. For sizes 40mm and above each kit includes 1 of each component.

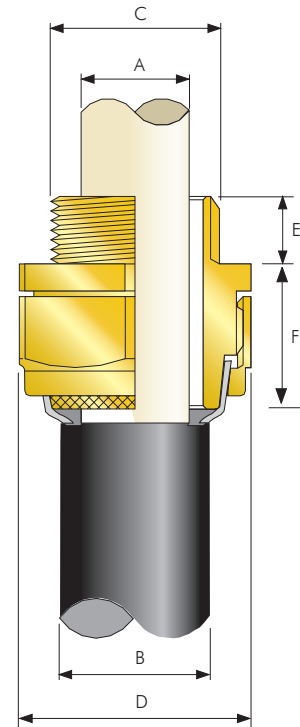

Cable Gland Selection Table

Cable Gland Size	Entry Thread 'C'	Minimum Thread Length 'E'	Cable Bedding Diameter 'A'	Overall Cable Diameter 'B'	Armour Range		Across Flats 'D'	Across Corners 'D'	Nominal Protrusion Length 'F'	PVC Shroud Reference	Cable Gland Weight (Kgs)
					Min	Max					
20S	M20	10.0	11.7	16.1	0.9	1.25	22.0	24.0	18.0	PVC02	0.09
20	M20	10.0	14.0	21.1	0.9	1.25	28.0	30.0	22.0	PVC05	0.10
25	M25	10.0	20.0	27.4	1.25	1.60	33.6	36.0	26.0	PVC07	0.15
32	M32	10.0	26.3	34.4	1.6	2.00	41.0	44.5	28.0	PVC10	0.20
40	M40	10.0	32.2	42.4	1.6	2.00	50.0	56.3	30.0	PVC13	0.36
50S	M50	15.0	38.2	50.1	2.0	2.50	57.1	63.4	30.0	PVC16	0.48
50	M50	15.0	44.1	55.7	2.0	2.50	61.0	72.1	32.0	PVC19	0.42
63S	M63	15.0	50.0	62.4	2.5	2.50	75.0	83.0	38.0	PVC22	0.80
63	M63	15.0	56.0	68.2	2.5	2.50	80.0	88.7	38.0	PVC24	0.85
75S	M75	15.0	62.0	76.8	2.5	2.50	90.0	99.8	40.0	PVC27	1.30
75	M75	15.0	75.0	82.9	2.5	3.15	95.0	105.3	40.0	PVC29	1.60

All dimensions in millimetres