

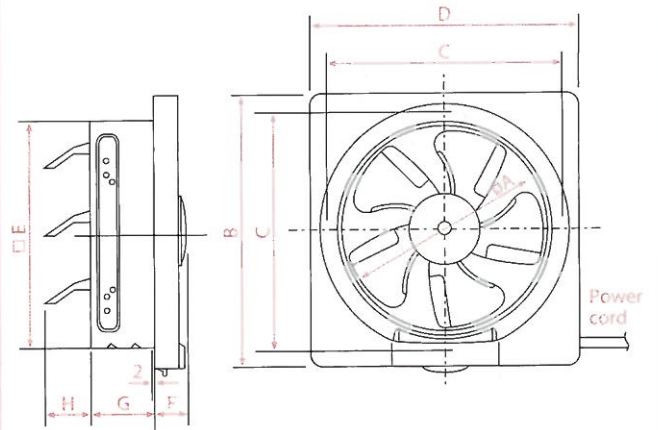

Dimension

Unit : mm



20AUH/25AUH/30AUH

- HP Condenser motor with thermo cut-off
- Well lubricated bearing for long life operation
- Propeller fan incorporated with advanced blade design (except 30AUH)
- Automatic shutter
- Single Speed

Model No.	A	B	C	D	E	F	G	H
20AUH	200	306	260	302	240	52	90	80
25AUH	250	356	310	352	290	38	90	63
30AUH	300	406	360	402	340	38	90	78

Specifications

Note: The value in Specification tables are representative characteristic value at 220V, 50/60Hz.

Model No.	Hz	Consumption [W]	R.P.M [min ⁻¹]	Air Volume		Noise [dB(A)]	Weight [Kg]	Installation space [mm]
				[CMH]	[CFM]			
20AUH	50	22	1,245	580	341	38	2	250 x 250
	60	29	1,400	650	383	42		
25AUH	50	29	1,125	920	541	39	2.4	300 x 300
	60	33	1,125	940	553	39		
30AUH	50	29	1,030	1,200	706	39	2.7	350 x 350
	60	33	950	1,140	671	38		

