

# Automatic Shutter Louver Series Wall Mount Type Ventilating Fan



## 20ALH/25ALH/30ALF

- HP Condenser motor with thermo cut-off
- Well lubricated bearing for long life operation
- Propeller fan incorporated with advanced blade design (except 30ALF)
- Automatic shutter
- Single Speed

### Dimension

Unit : mm

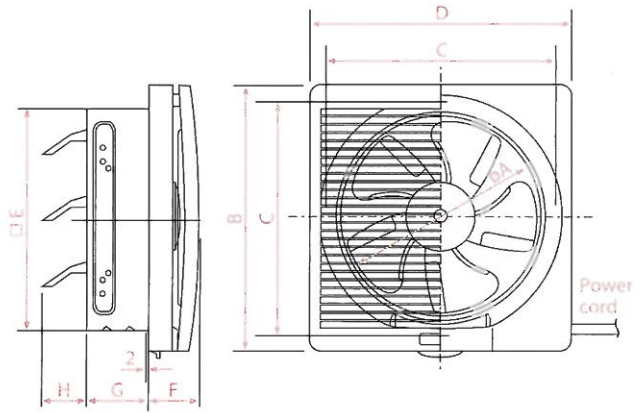

Model No.	A	B	C	D	E	F	G	H
20ALH	200	306	260	302	240	68	90	80
25ALH	250	356	310	352	290	63	90	63
30ALF	300	400	360	400	340	63	90	78

### Specifications

Note: The value in Specification tables are representative characteristic value at 220V, 50/60Hz.

Model No.	Hz	Consumption [W]	R.P.M [min <sup>-1</sup> ]	Air Volume		Noise [dB(A)]	Weight [Kg]	Installation space [mm]
				[CMH]	[CFM]			
20ALH	50	22	1,210	546	321	40	2.2	250 x 250
	60	29	1,340	600	353	44		
25ALH	50	29	1,055	835	491	43	2.7	300 x 300
	60	33	1,050	846	498	43		
30ALF	50	29	905	935	550	43	3.1	350 x 350
	60	33	835	915	539	43		

