

GSRM-40

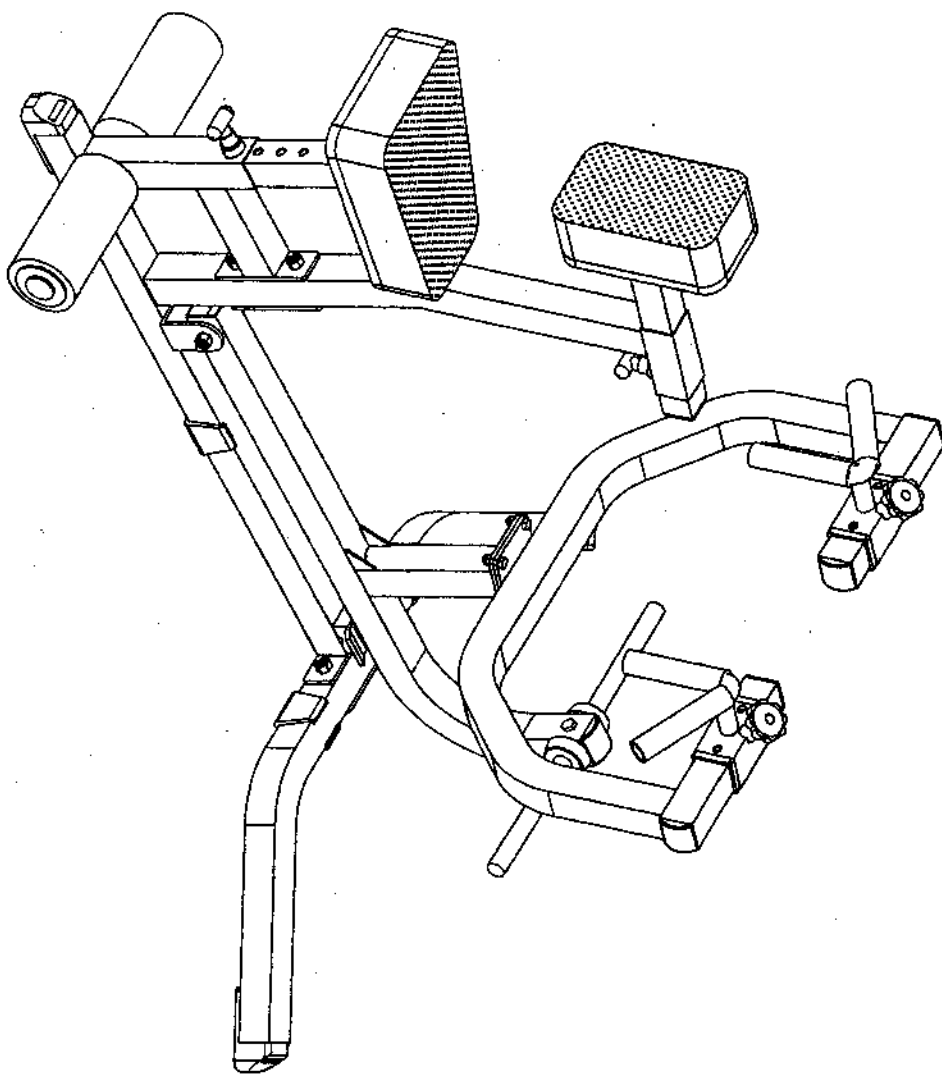

VERSION 0506

JSRM-40 HARDWARE ILLUSTRATION SHEET

	Qty.					
1. M12X75 HEX HEAD BOLT	[4PCS]	A1				
2. M10X25 HEX HEAD BOLT	[4PCS]	A2				
3. 5/16X1" HEX HEAD BOLT	[4PCS]	A3				
1. M12 NYLON LOCK NUT	[8PCS]	B1				
2. M10 NYLON LOCK NUT	[4PCS]	B2				
1. 5/16" (I.D.) WASHER	[8PCS]	C1				
2. 5/16" SPRING WASHER	[8PCS]	C2				
3. M10 (Ø19) WASHER	[8PCS]	C3				
1. Ø1" ROUND END CAP (8341-033)	[2PCS]	D1				
2. 2"X2" END CAP (9211-087)	[5PCS]	D2				
3. 1 3/4"X1 3/4" END CAP(9211-091)	[1PCS]	D3				
4. 60X50 NYLON BUSHING (9211-033)	[4PCS]	D4				
6. Ø3" NYLON WASHER (9214-008)	[2PCS]	D7				
7. 2"X2"(1.8t) FOOT CAP (9211-024)	[2PCS]	D8				
8. 2"X2"(2.5t) FOOT CAP (9211-025)	[1PCS]	D9				
9. 2"X2" RUBBER DONUT (9212-010)	[3PCS]	D10				
10. 4"X23X8" FOAM ROLLER (9161-009)	[2PCS]	D11				
11. Ø2 1/2"X3/4" RUBBER DONUT (9310-012)	[2PCS]	D12				
12. 1 1/2"X1 1/2" RUBBER BAR CATCH (9310-001)	[1PCS]	D13				
13. Ø6XØ13 RUBBER DONUT V STYLE (9214-004)	[2PCS]	D14				
14. 2"X2" END CAP (9211-005)	[1PCS]					

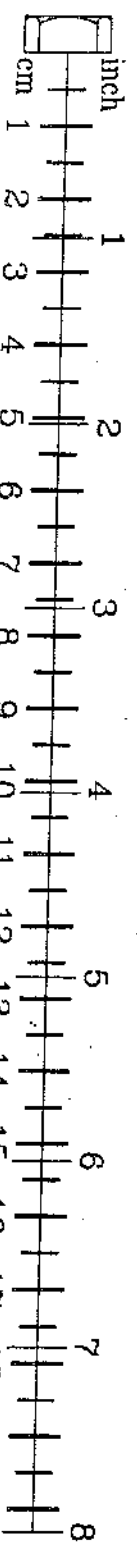

GSRM-40 PARTS ILLUSTRATION SHEET

A [1PCS]

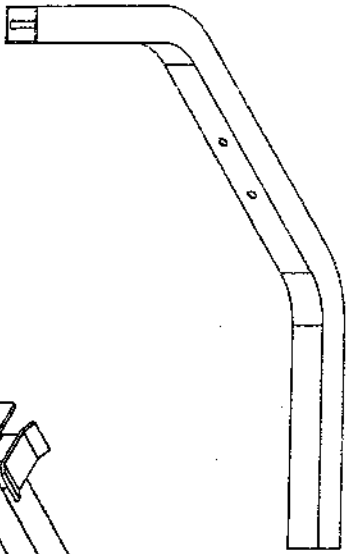

B [1PCS]

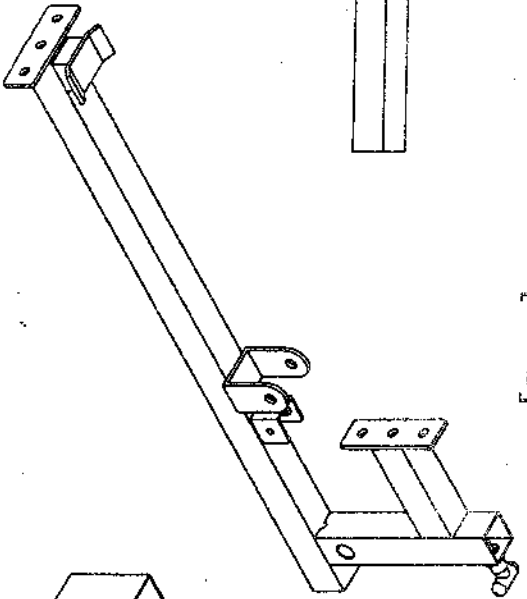

C [1PCS]

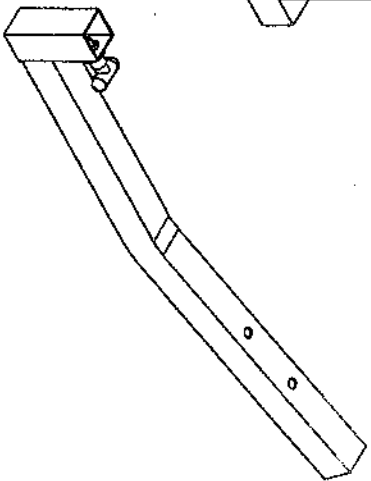

D [1PCS]

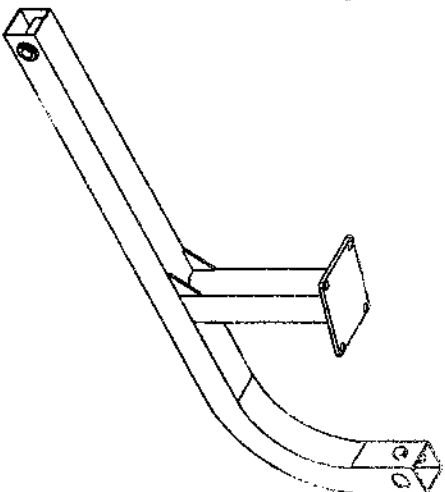

E [1PCS]

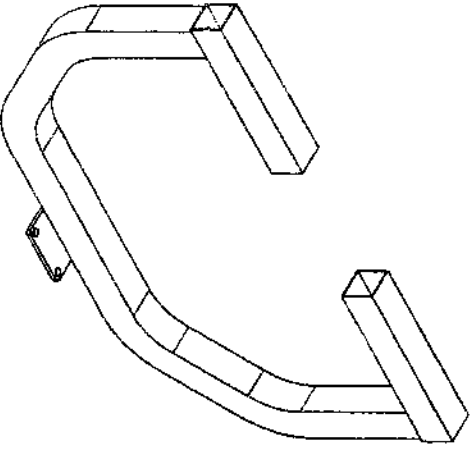

F [1PCS]
9122-004

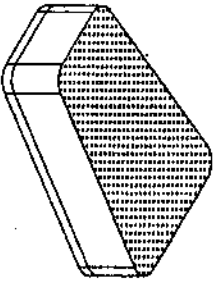

H [1PCS]
9132-006

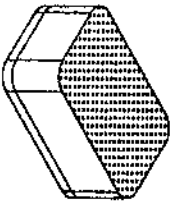

J [1PCS]

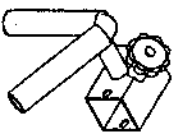

K [1PCS]
Ø25X510L

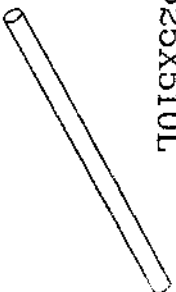

L [1PCS]
Ø1"X1.6tX493L

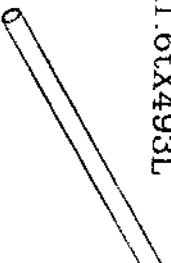

G [1PCS]

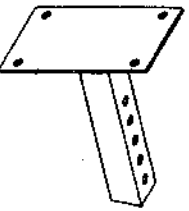

I [1PCS]

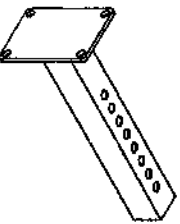

J-1 [1PCS]

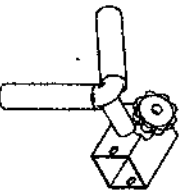

M [2PCS]
8312-062



