

EXM-4000.1

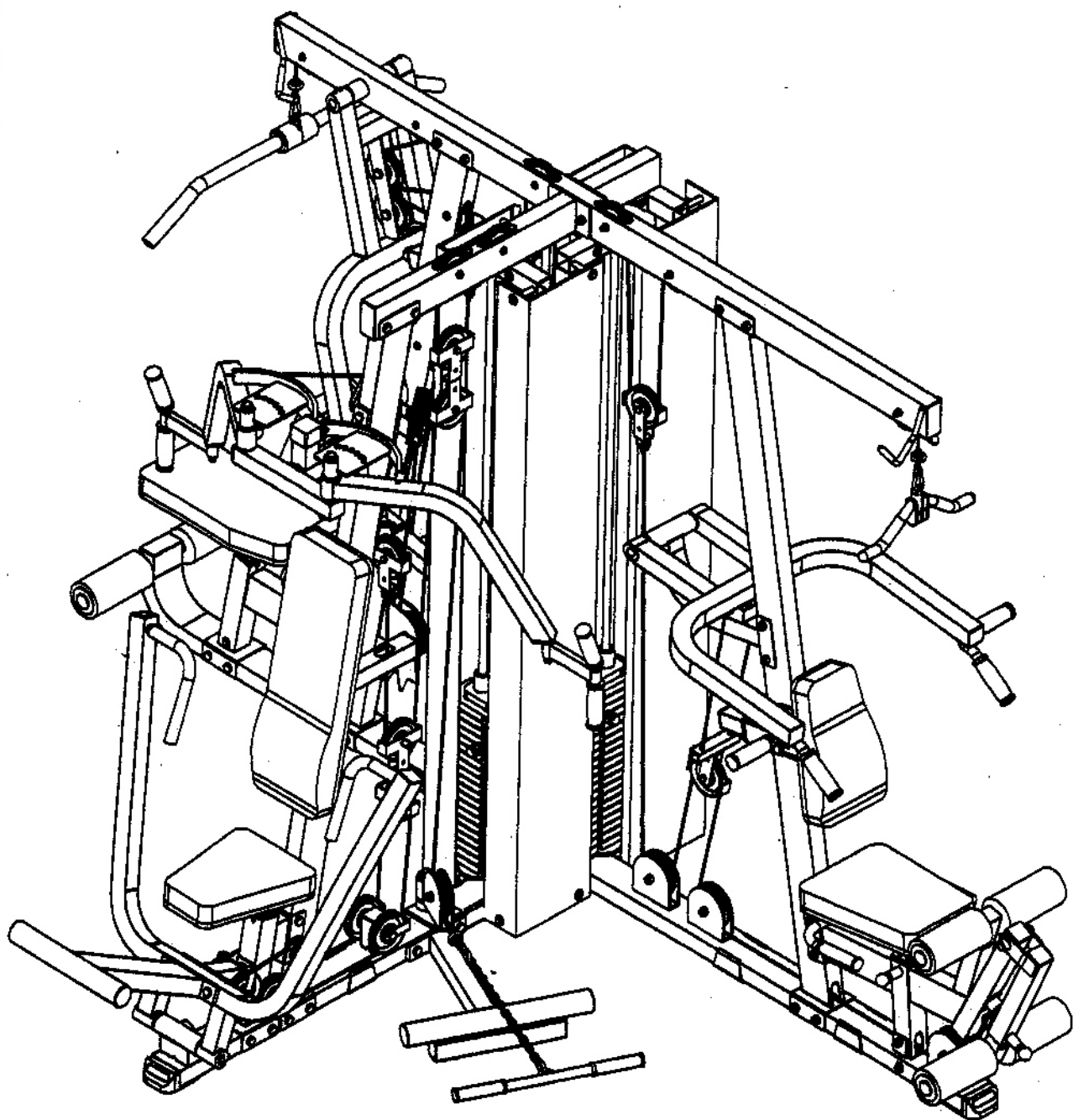

VERSION 0006







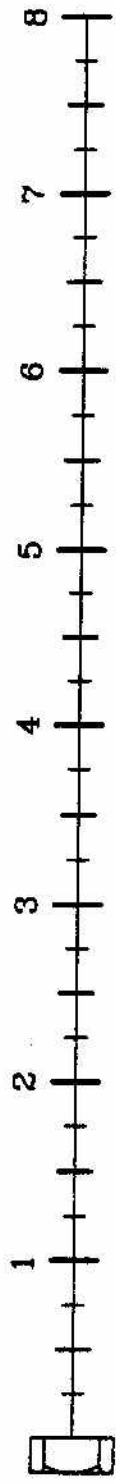
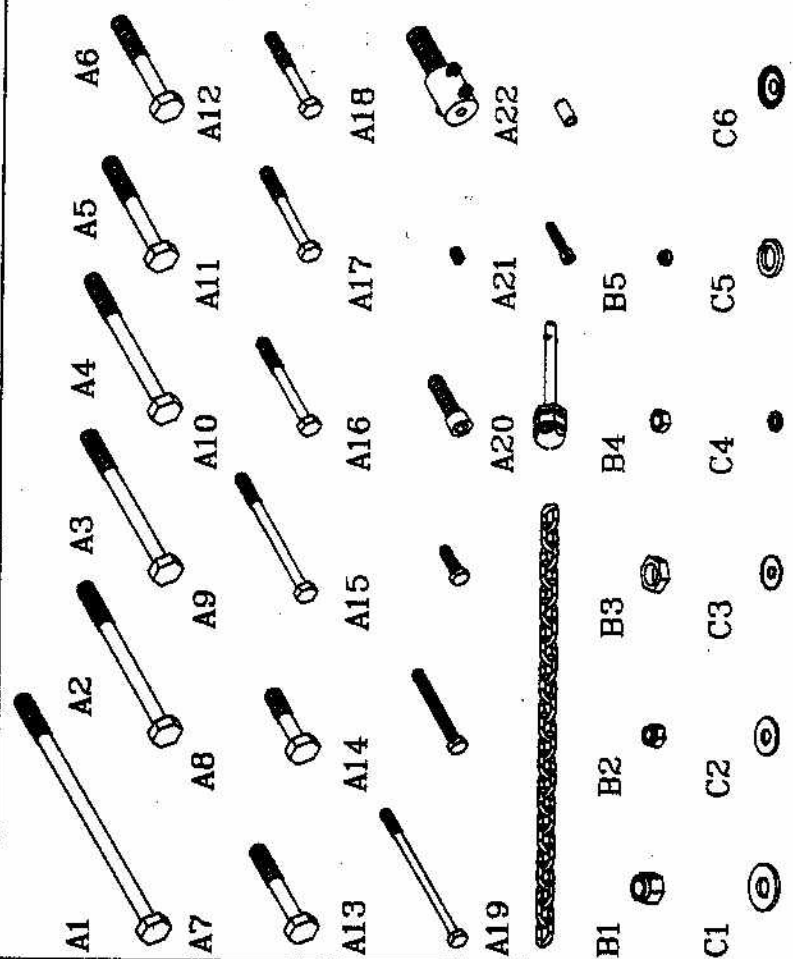

EXM-4000.1 HARDWARE ILLUSTRATION SHEET

B5. 3/16" NYLON LOCK NUT	[1PCS]
C1. 1/2" (I.D)WASHER	[8PCS]
C2. 3/8" (I.D) WASHER	[28PCS]
C3. 5/16" (I.D) WASHER	[20PCS]
C4. 5/16" SPRING WASHER	[20PCS]
C5. 5/8" SPRING WASHER	[3PCS]
C6. 3/8" ROUND END CAP WASHER	[2PCS]

A1. 1/2"x9" HEX HEAD BOLT	Qty. [2PCS]
A2. 1/2"x5 1/2" HEX HEAD BOLT	[5PCS]
A3. 1/2"x5 1/4" HEX HEAD BOLT	[2PCS]
A4. 1/2"x5" HEX HEAD BOLT	[10PCS]
A5. 1/2"x3 1/2" HEX HEAD BOLT	[3PCS]
A6. 1/2"x3 1/4" HEX HEAD BOLT	[6PCS]
A7. 1/2"x3" HEX HEAD BOLT	[18PCS]
A8. 1/2"x2" HEX HEAD BOLT	[9PCS]
A9. 3/8"x4 1/2" HEX HEAD BOLT	[1PCS]
A10. 3/8"x3 1/4" HEX HEAD BOLT	[16PCS]
A12. 3/8"x2 3/4" HEX HEAD BOLT	[20PCS]
A13. 5/16"x5" HEX HEAD BOLT	[2PCS]
A14. 5/16"x2 3/4" HEX HEAD BOLT	[2PCS]
A15. 5/16"x1" HEX HEAD BOLT	[16PCS]
A16. 7/16X1 1/2" ROUND BOLT	[3PCS]
A17. 5/16"x3/8" SET SCREW	[9PCS]
A18. 5/8" ROUND BOLT	[3PCS]
A19. STEEL CHAIN	[1PCS]
A20. PIN	[3PCS]
A21. 5/16"x1 1/2" ROUND BOLT	[1PCS]
A22. Ø1/2"x22L SLEEVE	[1PCS]
B1. 1/2" NYLON LOCK NUT	[55PCS]
B2. 3/8" NYLON LOCK NUT	[21PCS]
B3. 5/8" LOCK NUT	[3PCS]
B4. 3/8" LOCK NUT	[2PCS]



EXM-4000.1 HARDWARE ILLUSTRATION SHEET

	Qty.		
D1. 3/8" BOLT CAP	[2PCS]	D31. 3410mm STEEL CABLE	[1PCS]
D2. 1/4"X3/8" PULLEY (E4047)	[10PCS]	D32. 575mm STEEL CABLE	[2PCS]
D3. 1/4"X1/2" PULLEY (E4047)	[15PCS]	D33. 3910mm STEEL CABLE	[1PCS]
D4. 2"X4" FOOT CAP (E4087A)	[2PCS]	D34. 4790mm STEEL CABLE	[1PCS]
D5. 2"X4" RUBBER DOUNT (E4090)	[6PCS]	D35. 3450mm STEEL CABLE	[1PCS]
D6. 2"X2"X2.5t END CAP (E4043)	[16PCS]	D36. 2400mm STEEL CABLE	[1PCS]
D7. 2"X2"X1.8t END CAP (E4001)	[1PCS]	D37. 2135mm STEEL CABLE	[1PCS]
D8. 1 3/4"X1 3/4" END CAP (E4002)	[4PCS]	D38. 2880mm STEEL CABLE	[1PCS]
D9. 30X30 END CAP (E4026)	[2PCS]	D39. 3160mm STEEL CABLE	[1PCS]
D10. 2"X4" END CAP (E4049A)	[5PCS]	D40. 40X31X40 TWO-SIDED TAPE (F4053)	[24PCS]
D11. 1" ROUND END CAP (E10128)	[8PCS]	D41. 1/4"X8L STEEL BUSHING (E10138)	[6PCS]
D12. 1"X34X135 RUBBER GRIP (E4068)	[4PCS]	D42. 1/4" SHAFT COLLAR (E4129)	[6PCS]
D13. 1"X41X135 RUBBER GRIP (E4082)	[12PCS]		
D14. 2"X2" RUBBER DOUNT (E2009)	[1PCS]	D1. 	D2
D15. 1/2"X62L BUSHING (E10137)	[16PCS]	D8. 	D9
D16. 1/4" RUBBER DOUNT (E2022)	[6PCS]	D15. 	D16
D17. 1/8" SPRING SNAP LINK (E5000)	[5PCS]	D22. 	D23
D18. 95X140mm NO-SLIP TAPE (E5024)	[4PCS]	D28. 	D29
D19. 1/2"X15 STEEL BUSHING (E3015)	[20PCS]	D31. 	D32
D21. 2"X2" RUBBER CANE CAP (E4039)	[8PCS]	D34. 	D35
D22. 150X245mm NO-SLIP TAPE (E5026)	[1PCS]	D37. 	D38
D23. 1/2" NYLON WASHER (E4085)	[8PCS]	D40. 	D41
D25. 60X45 NYLON BUSHING (E4008)	[4PCS]		D42
D26. 1/2" CU WASHER (E3026)	[2PCS]		D43
D27. 1" ROUND END CAP (E4012)	[2PCS]		D44
D28. TOP PLATE (F5068)	[3PCS]		D45
D29. WEIGHT SELECTOR BAR (E10113)	[3PCS]		D46
D30. 1/4"X8" FOAM ROLLER (F4041)	[8PCS]		D47

EXM-4000.1 PARTS ILLUSTRATION SHEET

A [1PCS]

BOX 3 OF 9

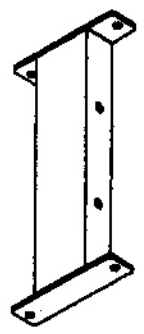

B [1PCS]

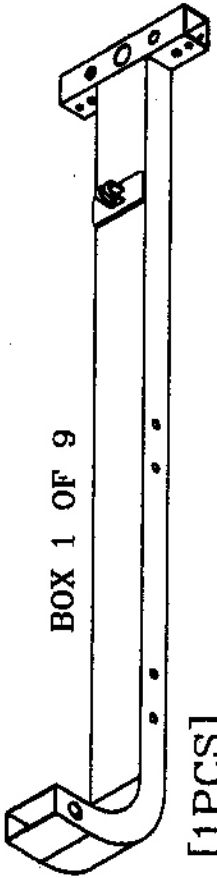

BOX 1 OF 9

C [1PCS]

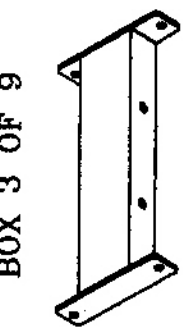

BOX 1 OF 9

D [1PCS]

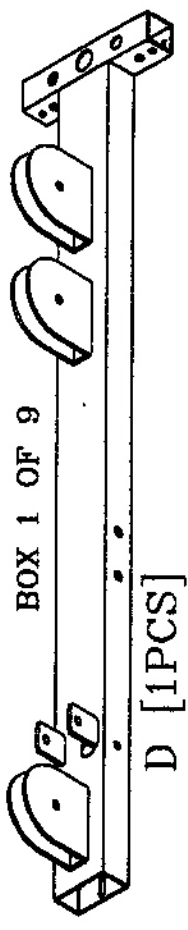

E [1PCS]

BOX 2 OF 9

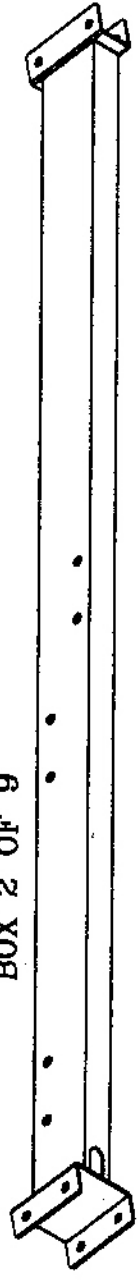

I [1PCS]

BOX 3 OF 9

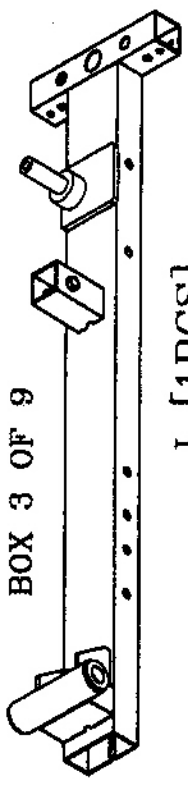

F [1PCS]

BOX 2 OF 9

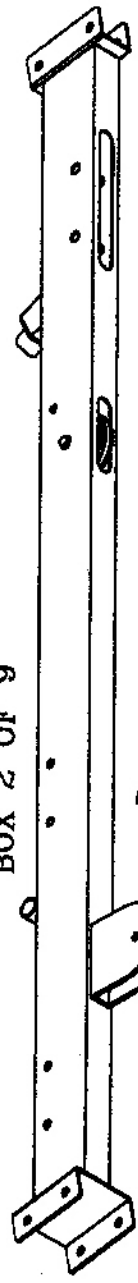

J [1PCS]

BOX 1 OF 9

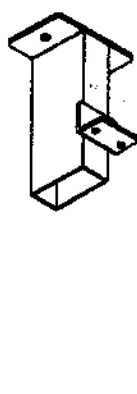

G [1PCS]

BOX 2 OF 9



K [4PCS]

BOX 2 OF 9



H [1PCS]

BOX 1 OF 9

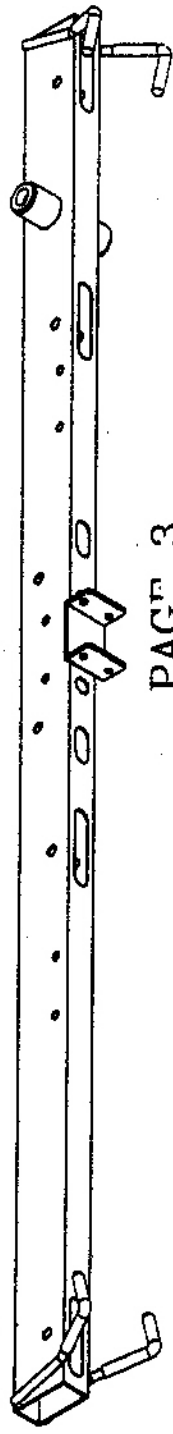

EXM-4000.1 PARTS ILLUSTRATION SHEET

L [1PCS]
BOX 6 OF 9

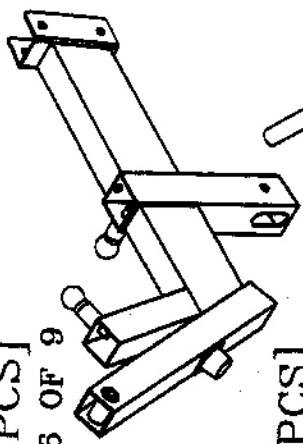

S [1PCS]
BOX 5 OF 9

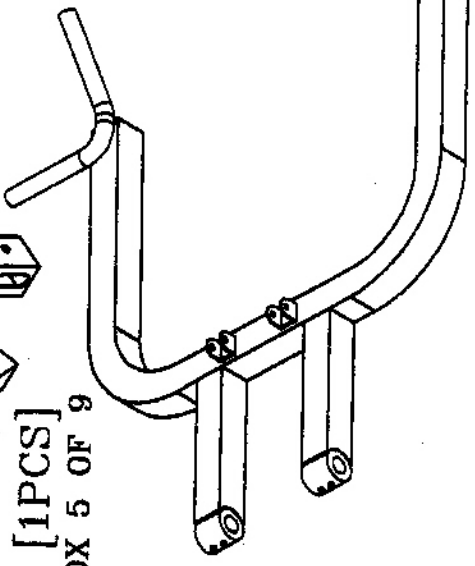

M [1PCS]
BOX 6 OF 9



N [2PCS]
BOX 6 OF 9



T [2PCS]
BOX 6 OF 9



U [1PCS]
BOX 5 OF 9

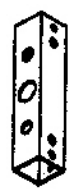

O [1PCS]
BOX 6 OF 9

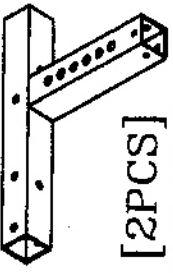

P [2PCS]
BOX 3 OF 9



V [1PCS]
BOX 8 OF 9

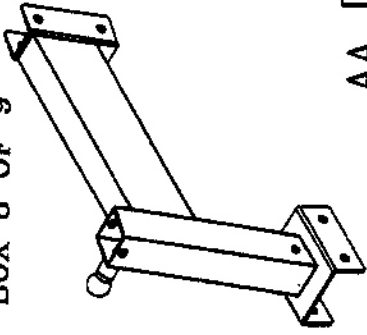

Z [1PCS]
BOX 5 OF 9

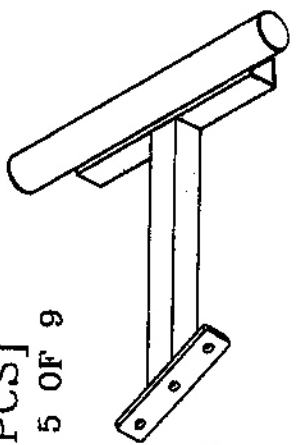

Q [1PCS]
BOX 6 OF 9

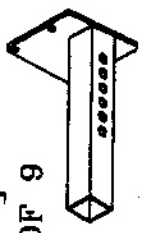

R [1PCS]
BOX 6 OF 9

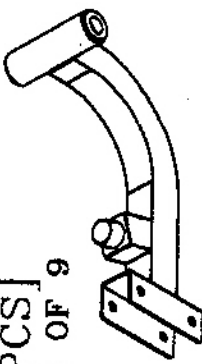

W [1PCS]
BOX 8 OF 9

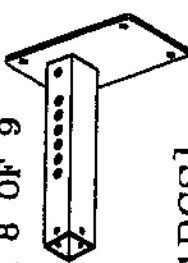

X [1PCS]
BOX 5 OF 9

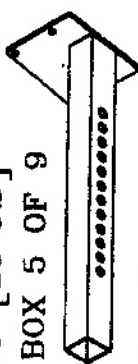

AA [1PCS]
BOX 3 OF 9

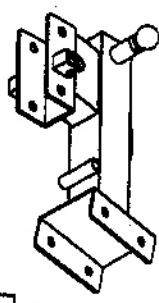

AB [1PCS]
BOX 3 OF 9

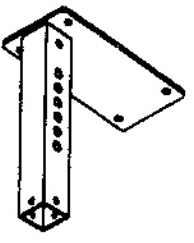

Y [1PCS]
BOX 8 OF 9

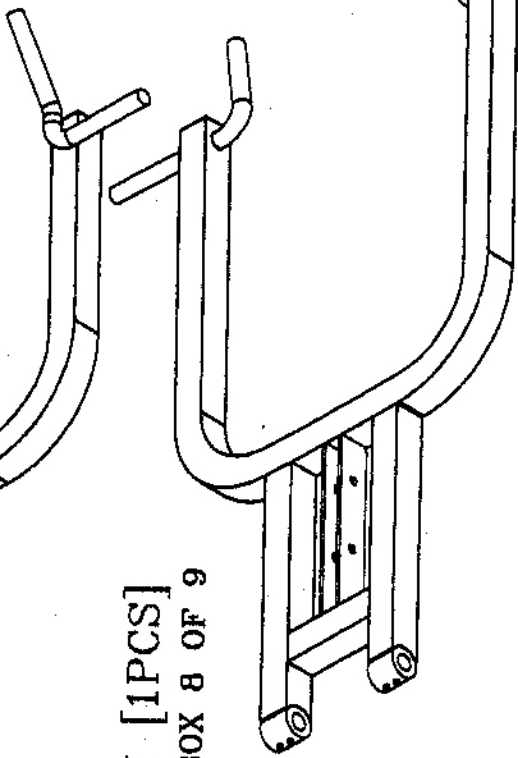

EXM-4000.1 PARTS ILLUSTRATION SHEET

AC [1PCS]
BOX 4 OF 9

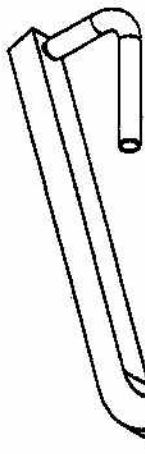

AD [1PCS]
BOX 3 OF 9

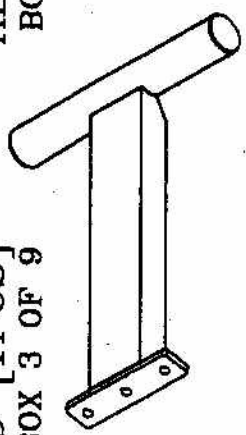

AE [1PCS]
BOX 6 OF 9

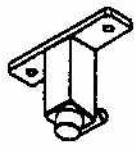

AF [1PCS]
BOX 3 OF 9

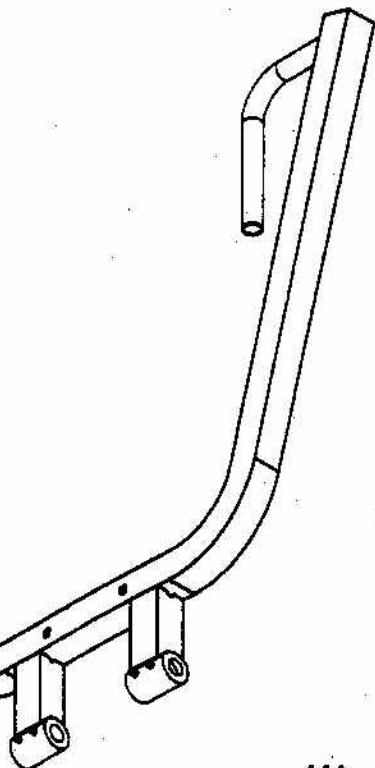
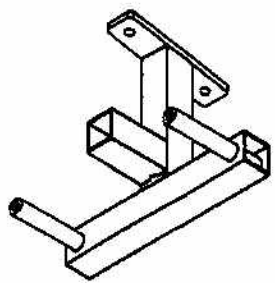

AG [1PCS]
BOX 3 OF 9

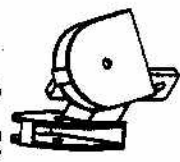

AH [1PCS]
BOX 6 OF 9

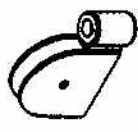

AI [1PCS]
BOX 6 OF 9



AJ [2PCS]
BOX 6 OF 9



AK [1PCS]
BOX 6 OF 9

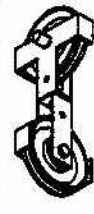

AL [1PCS]
BOX 6 OF 9



AM [2PCS]
BOX 6 OF 9

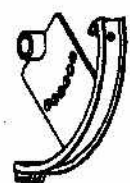

AN [1PCS]
BOX 4 OF 9

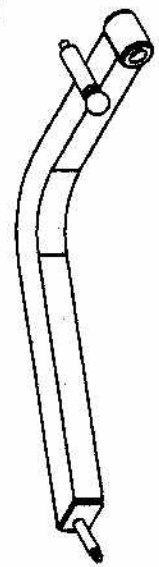

AO [1PCS]
BOX 4 OF 9

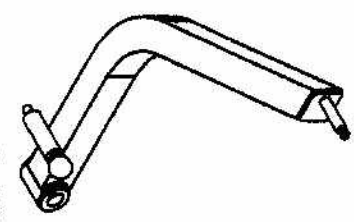

AP [1PCS]
BOX 3 OF 9

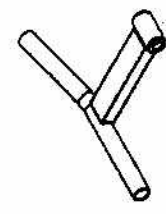

AQ [1PCS]
BOX 3 OF 9

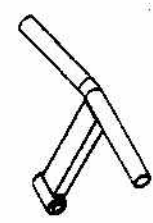

EXM-4000.1 PARTS ILLUSTRATION SHEET

AR [1PCS]
BOX 5 OF 9

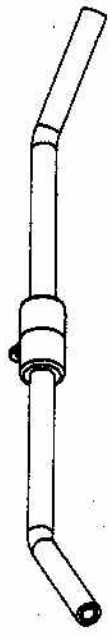

AS [1PCS]
BOX 5 OF 9



AT [1PCS]
BOX 5 OF 9



AU [1PCS]
BOX 5 OF 9



AV [6PCS]
BOX 9 OF 9

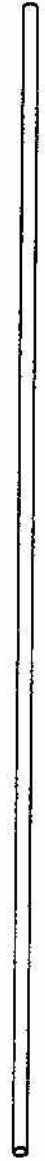

AW [3PCS] ϕ 1"X510L
BOX 5 OF 9

AX [1PCS] ϕ 1"X560L
BOX 5 OF 9



AY [6PCS]
BOX 4 OF 9



AZ [2PCS]
BOX 6 OF 9



BA [8PCS]
BOX 7 OF 9

BB [4PCS]
BOX 7 OF 9

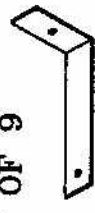
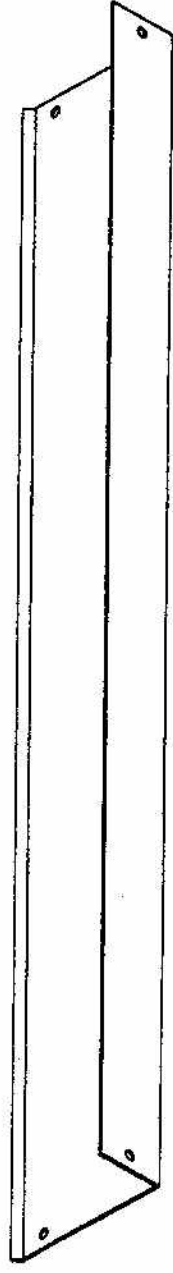

BC [1PCS]
BOX 5 OF 9

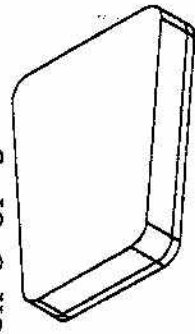

BD [1PCS]
BOX 5 OF 9

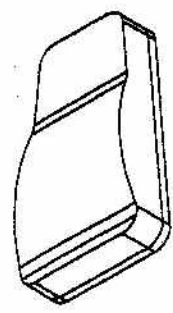

BE [1PCS]
BOX 8 OF 9

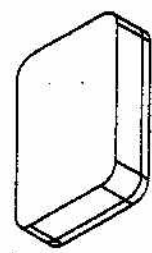

BF [1PCS]
BOX 8 OF 9

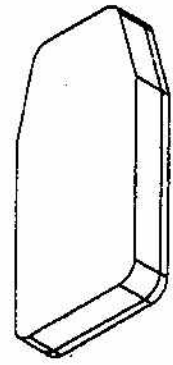

BG [1PCS]
BOX 4 OF 9

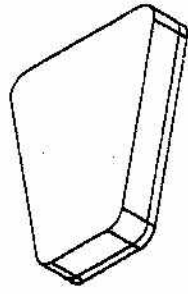

BH [1PCS]
BOX 4 OF 9

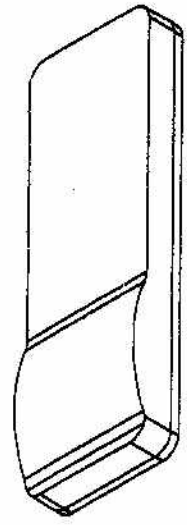

EXM-4000.1

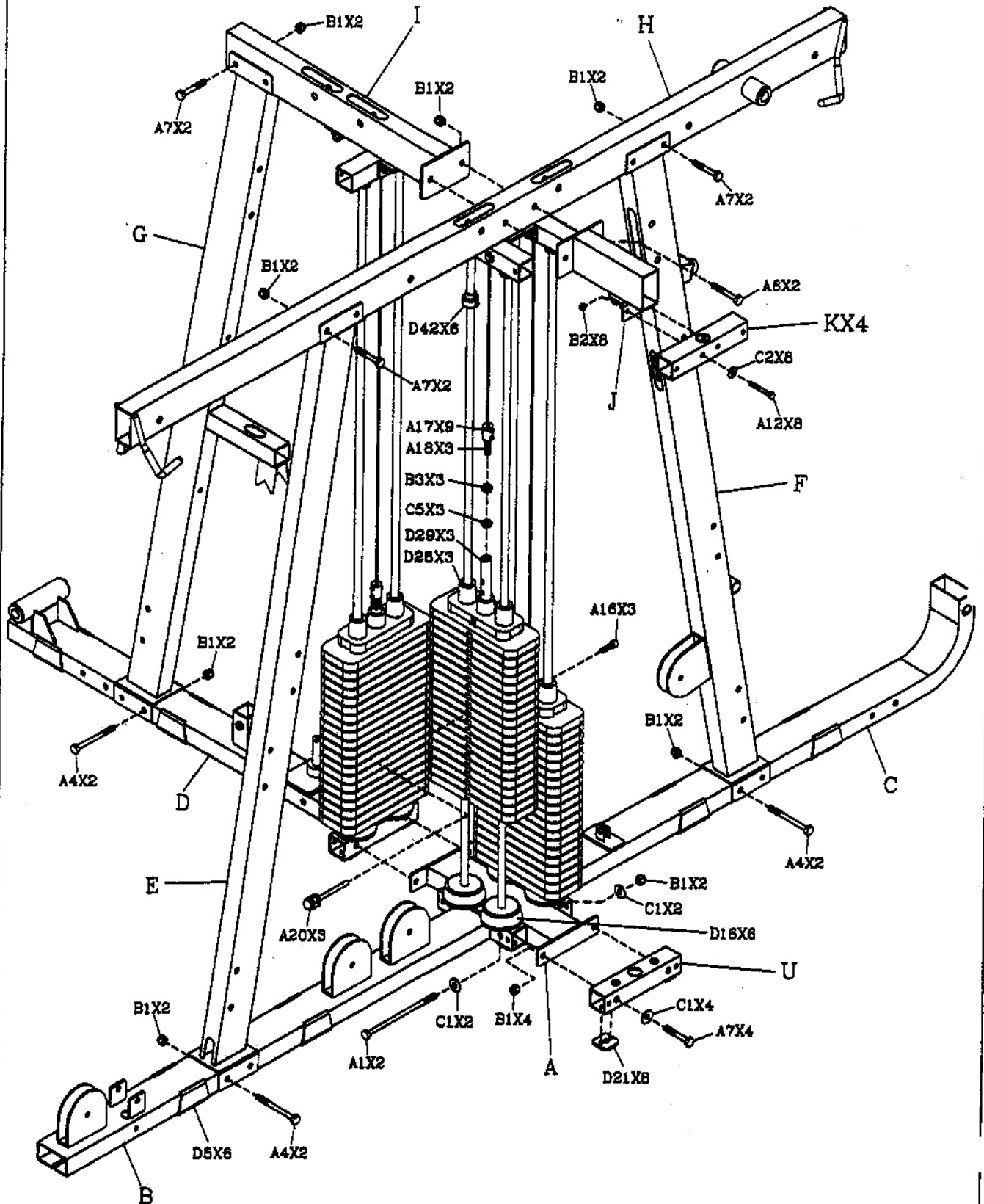

PAGE 7

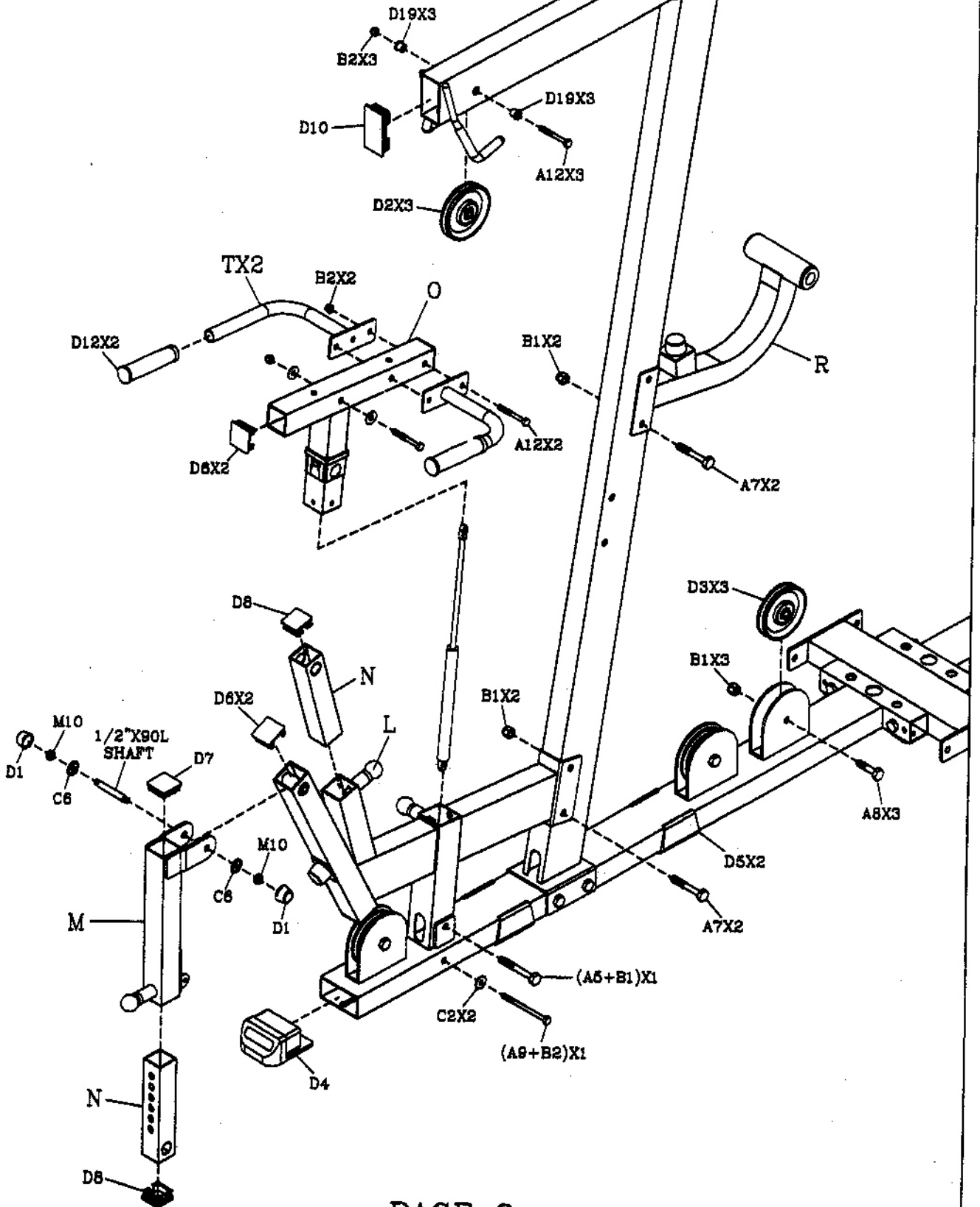

EXM-4000.1

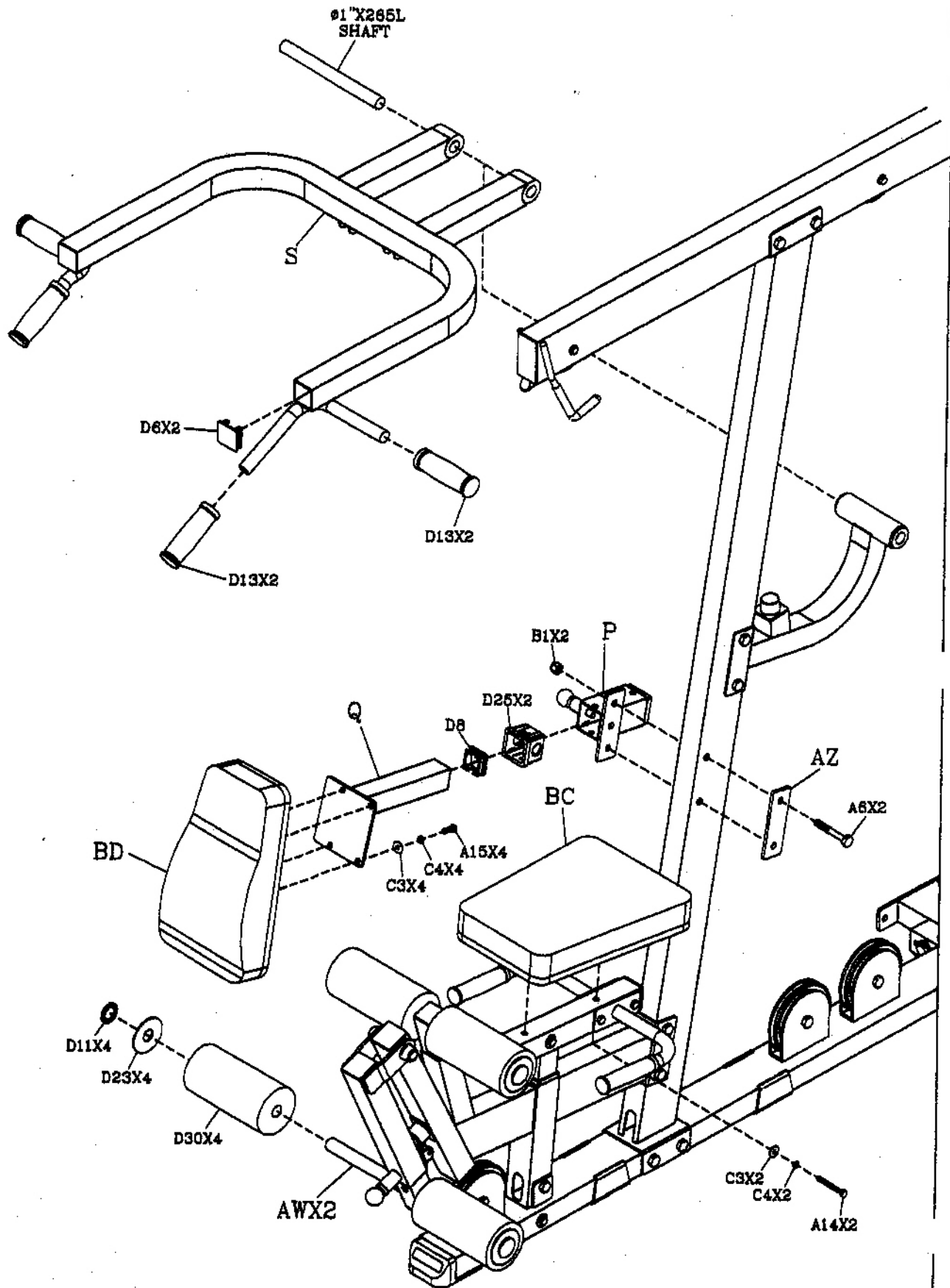

EXM-4000.1

You must run cable through tubing
and over pivot point/or bolts.

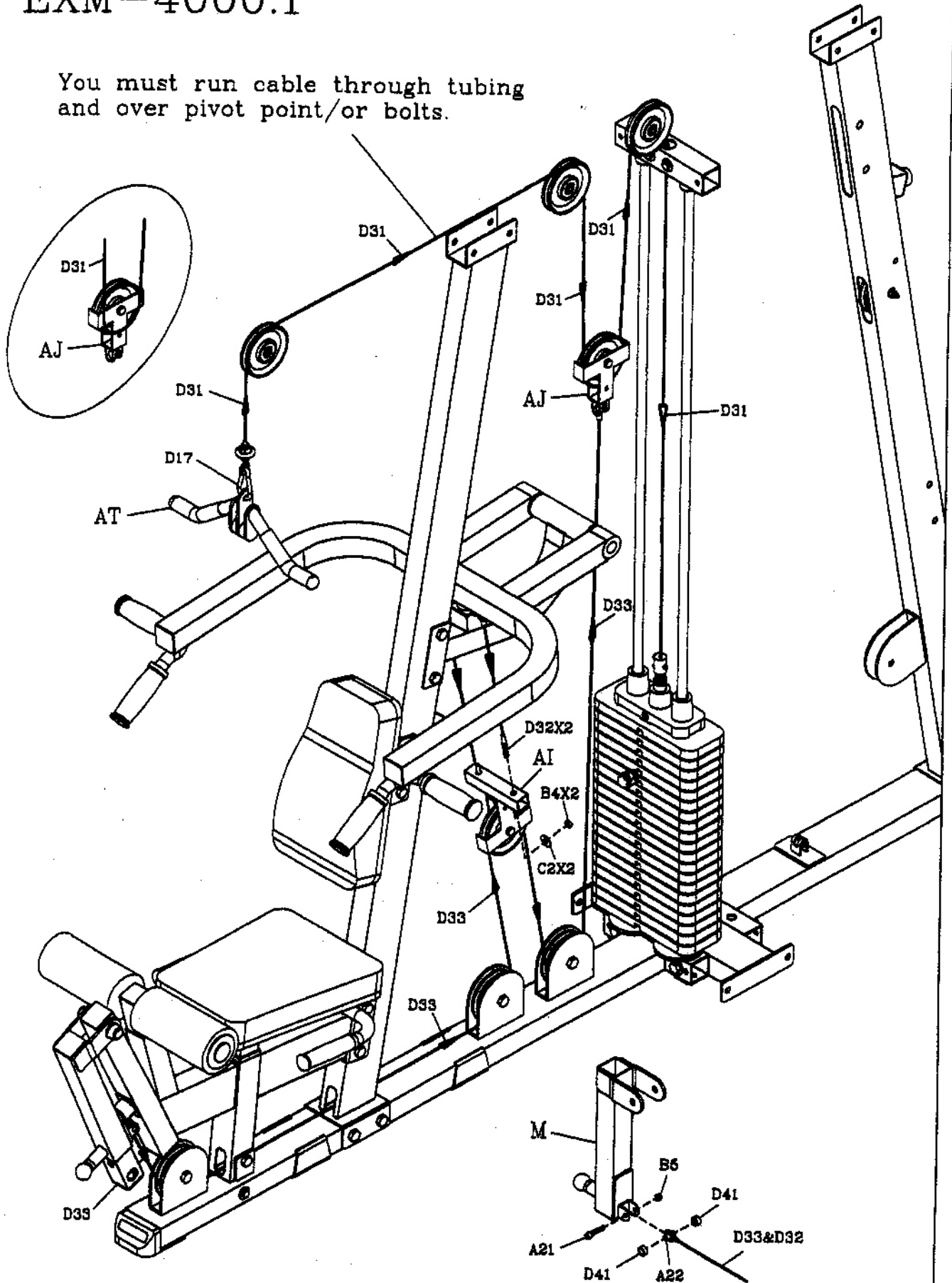

EXM-4000.1

Tricep Press Down
Shoulder Press
Leg Curl/Leg Extension

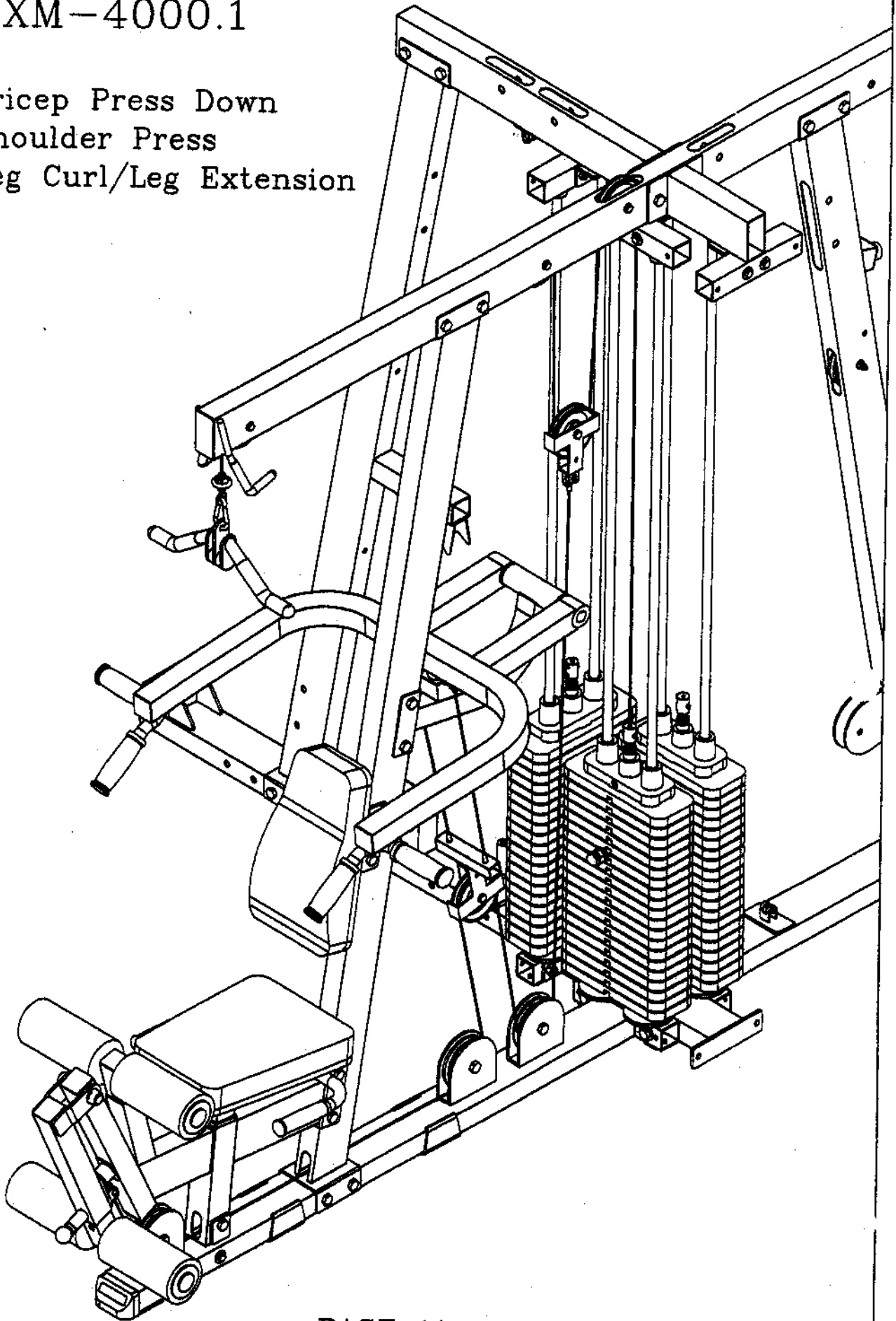

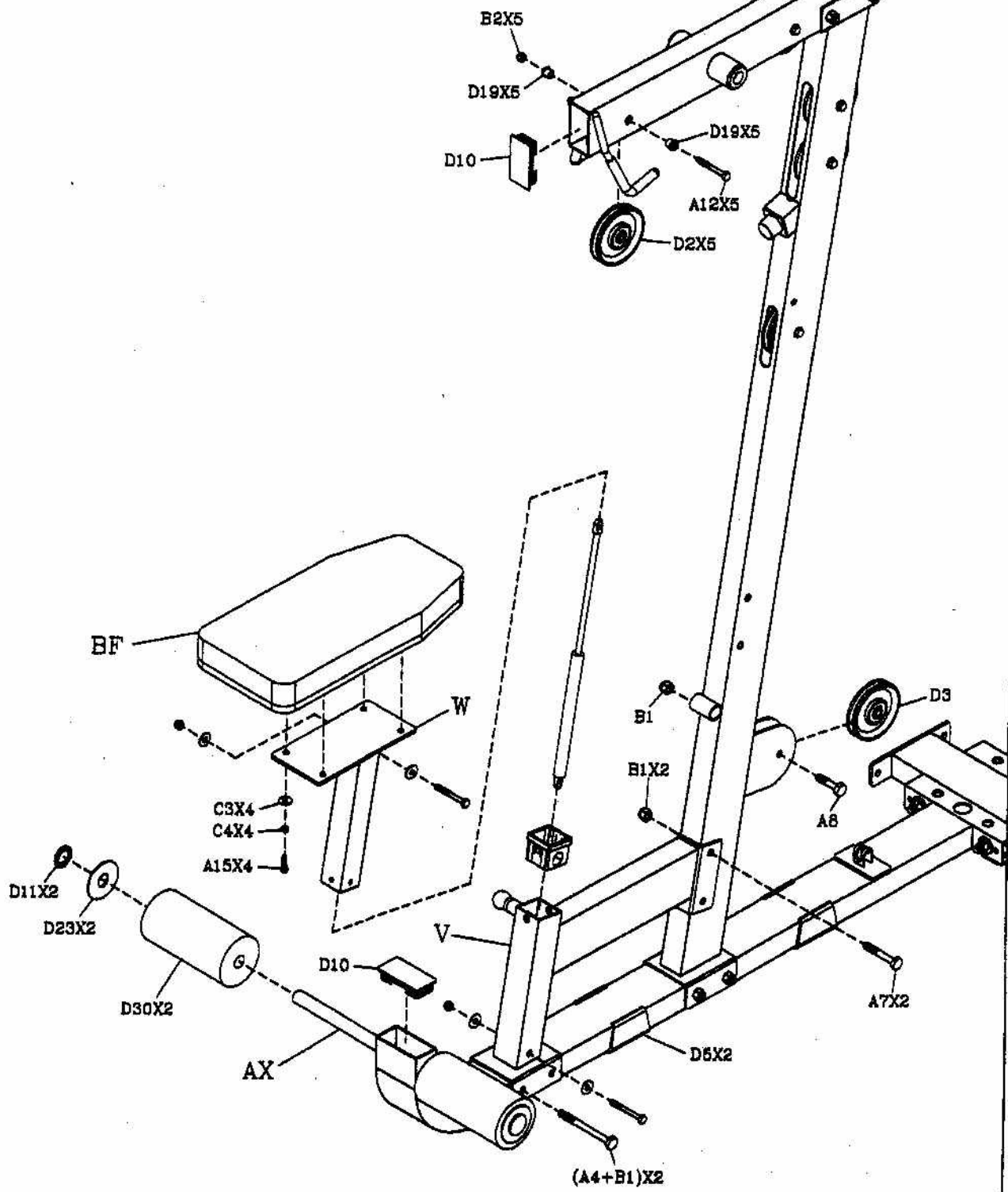

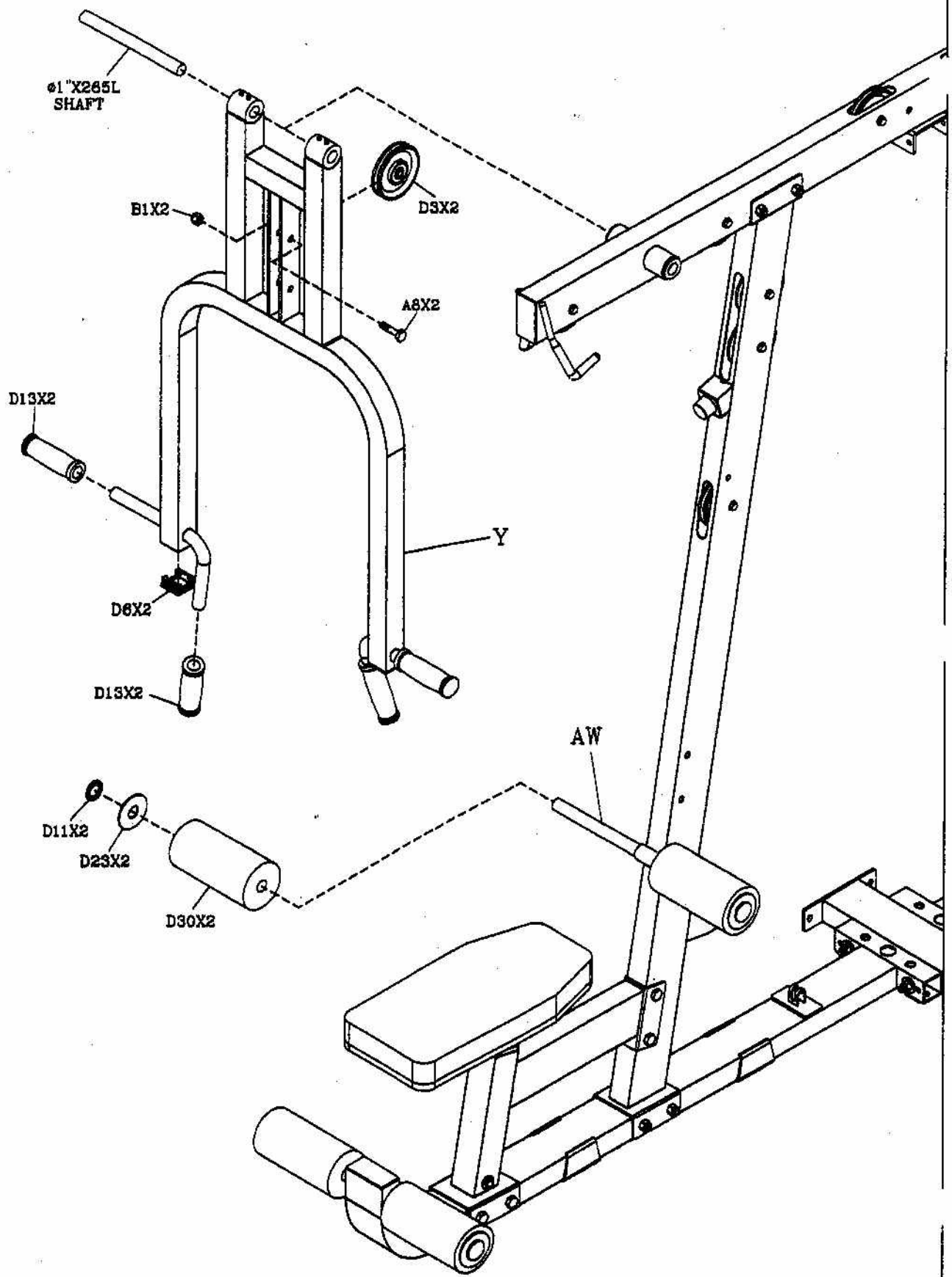

EXM-4000.1

THERE IS A RISK ASSUMED BY INDIVIDUALS WHO USE THIS TYPE OF EQUIPMENT. TO MINIMIZE RISK, YOU MUST FOLLOW THESE RULES:

1. Inspect equipment before each workout. Check that all nuts, bolts, screws and pop pins are in place and fully tightened. Also, before use, check cables for signs of wear. Replace all worn parts immediately. Never use machine if any parts are damaged or missing. Failure to follow these rules may result in serious injury.
2. Keep clear of the cables and all moving parts when the machine is in use.
3. Always make sure all Snap Links are closed when doing any cable/pulley exercises.
4. Exercise with care. Perform your exercises at a smooth moderate pace; never perform jerky or uncoordinated movements that may cause injury.
5. It is recommended that you should workout with a training partner.
6. Do not allow children or minors to play on or around this equipment.
7. If unsure of proper use of equipment, call your local Body-Solid distributor or the Body-Solid customer service department at 1-800-858-3113.
8. **WARNING:** Consult your physician before starting your exercise program. For your own safety, do not begin any exercise program without proper instruction.

RAL2-11-98

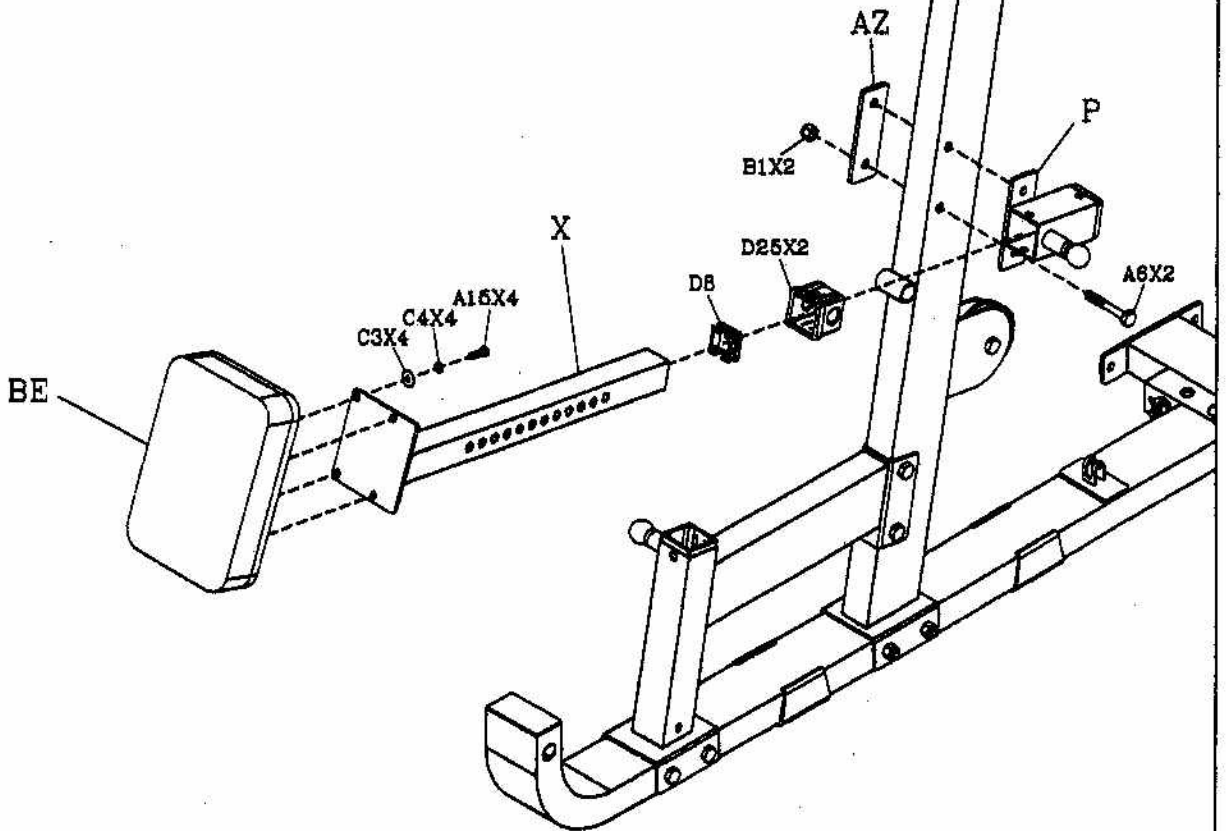

You must run cable through tubing and over pivot point/or bolts.

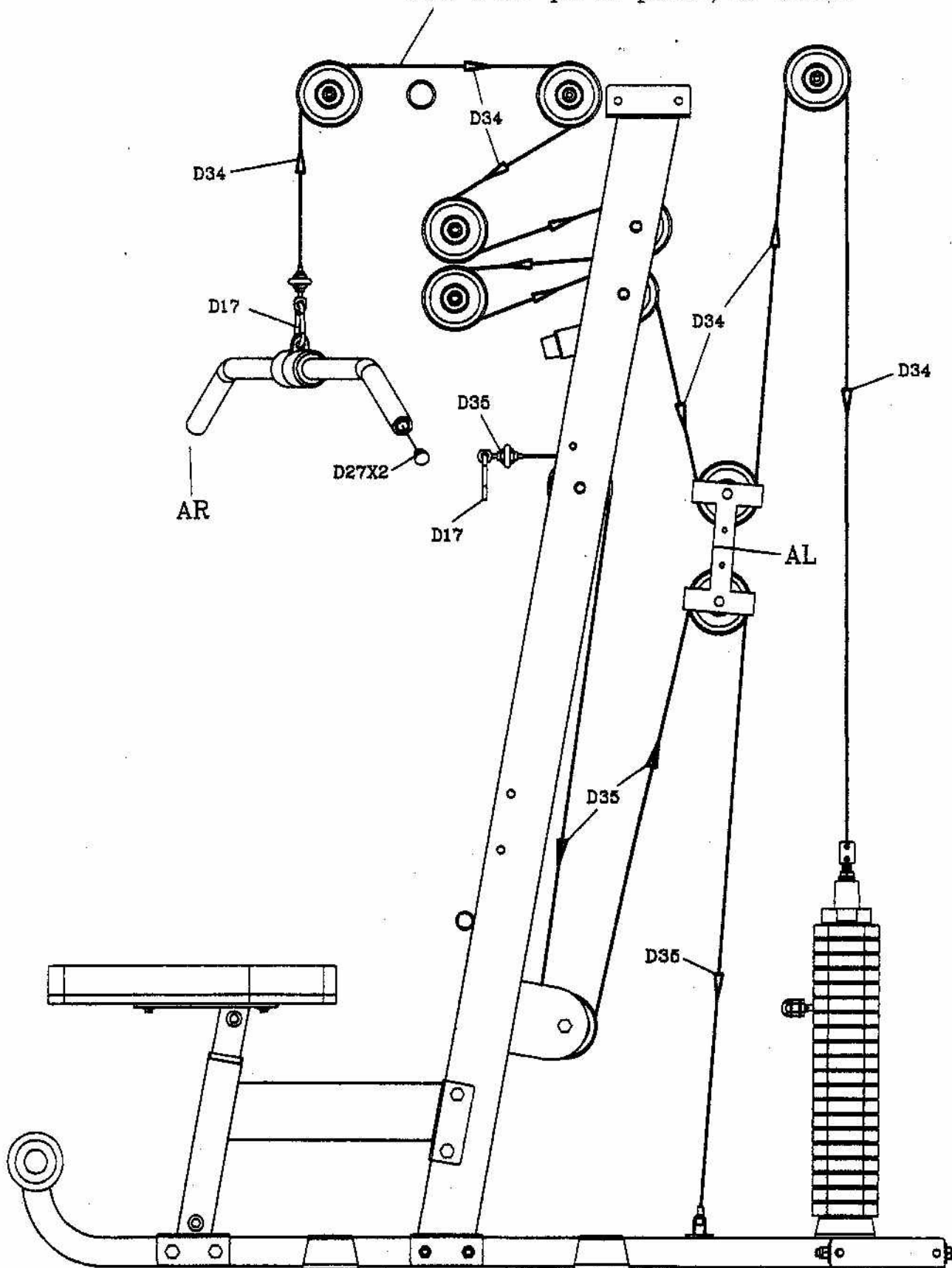

EXM-4000.1

Lat Pull Down
Ab Crunch/Tricep Extension
Mid Row

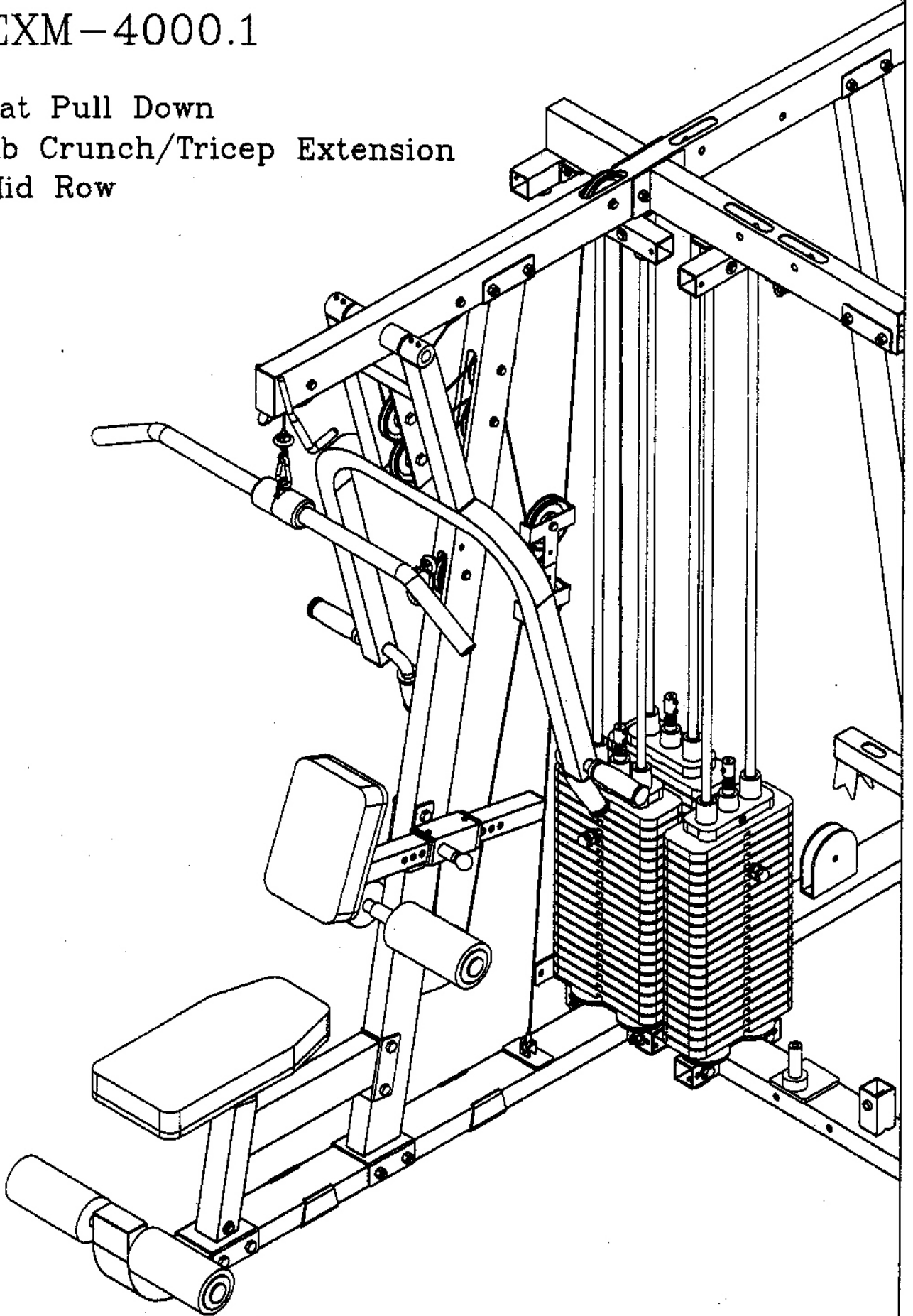

EXM-4000.1

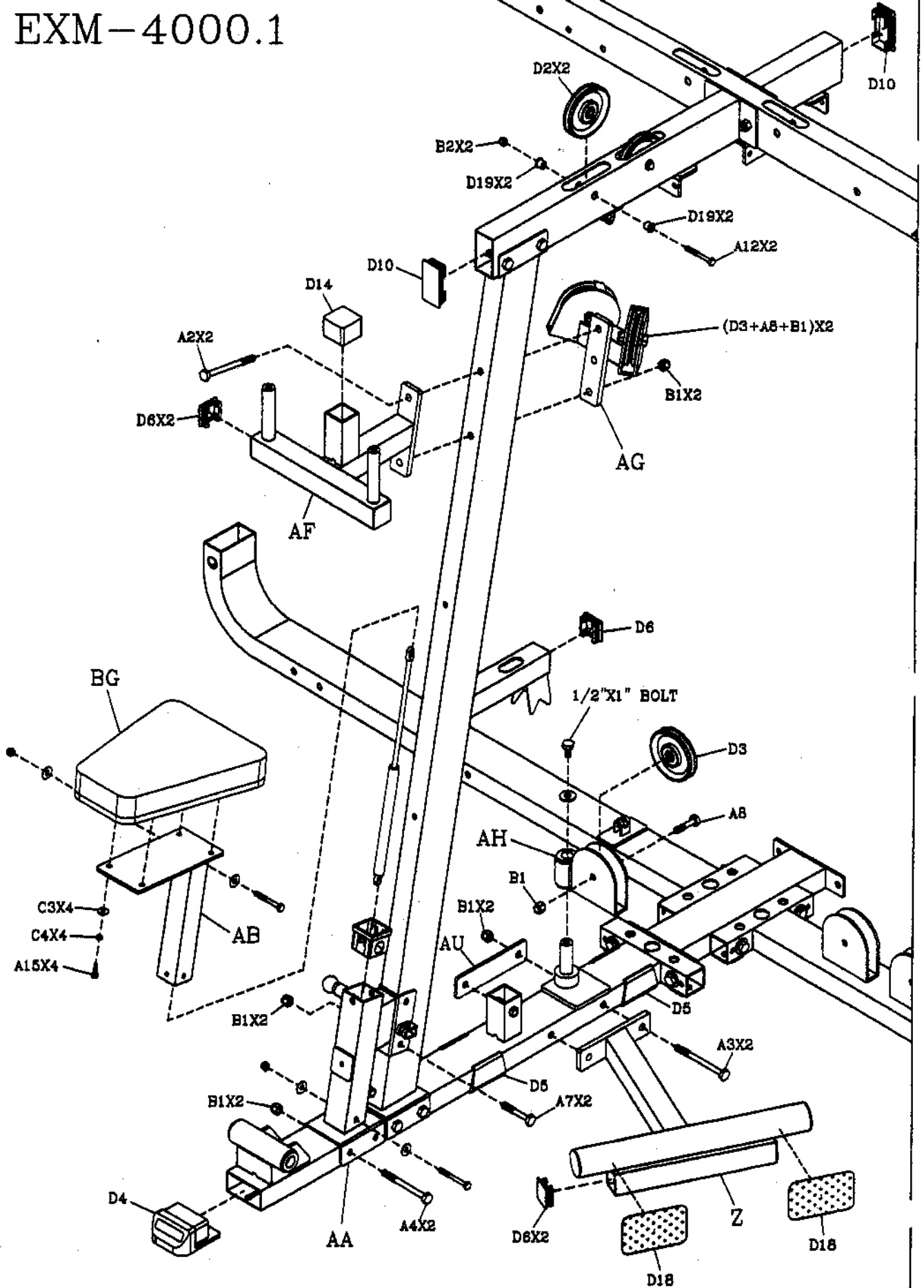

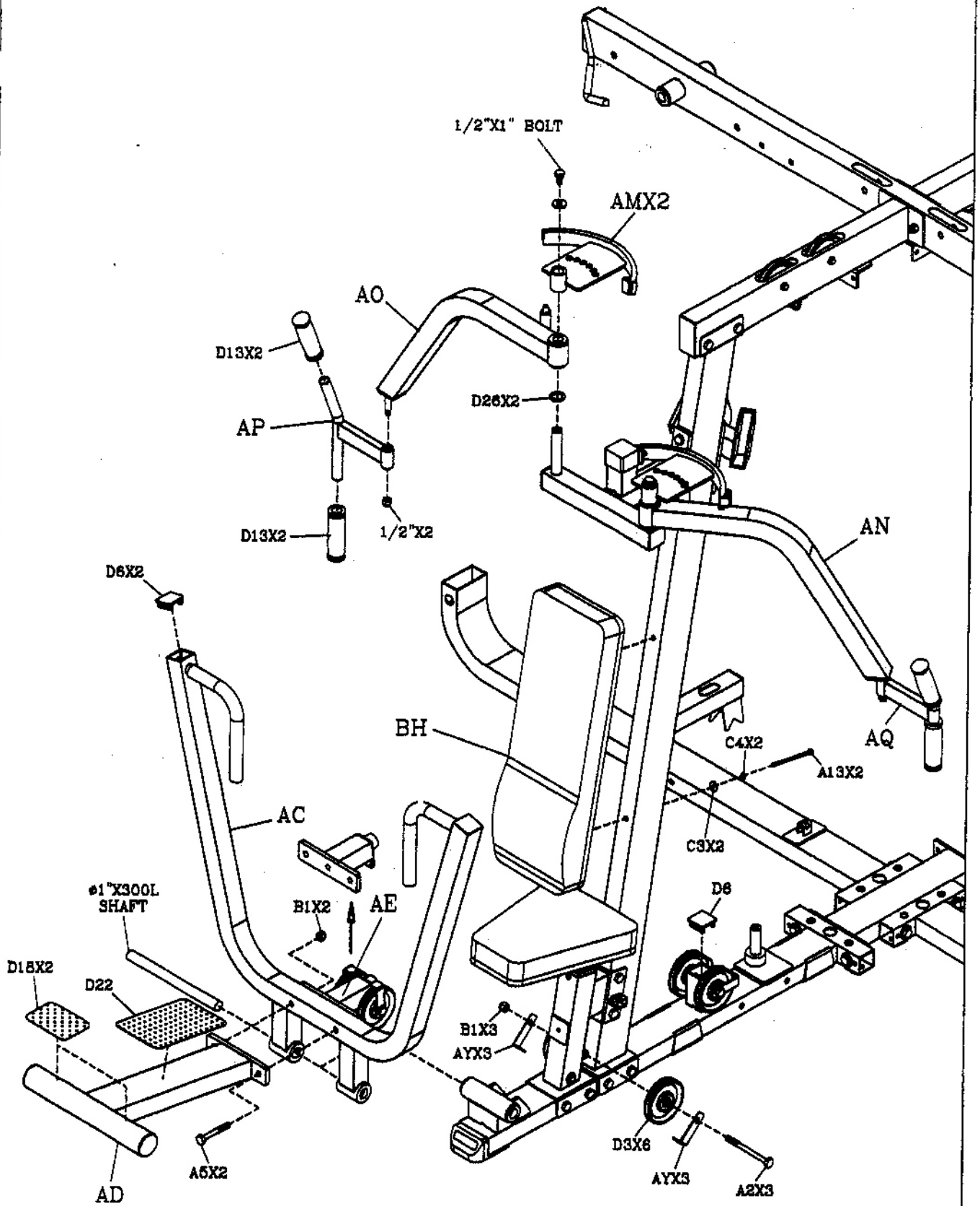

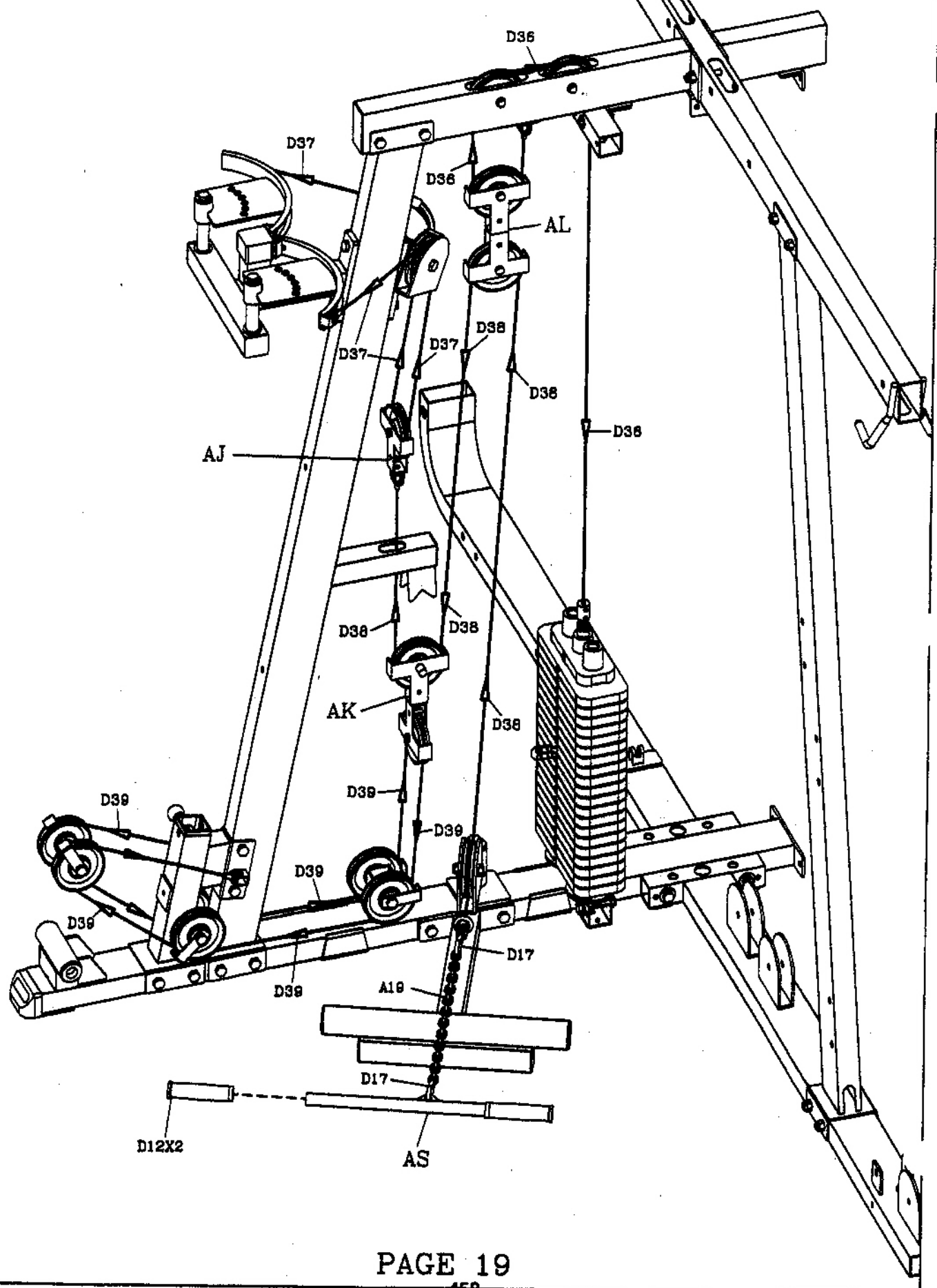

EXM-4000.1

Pectoral Fly
Bench Press
Low Pulley

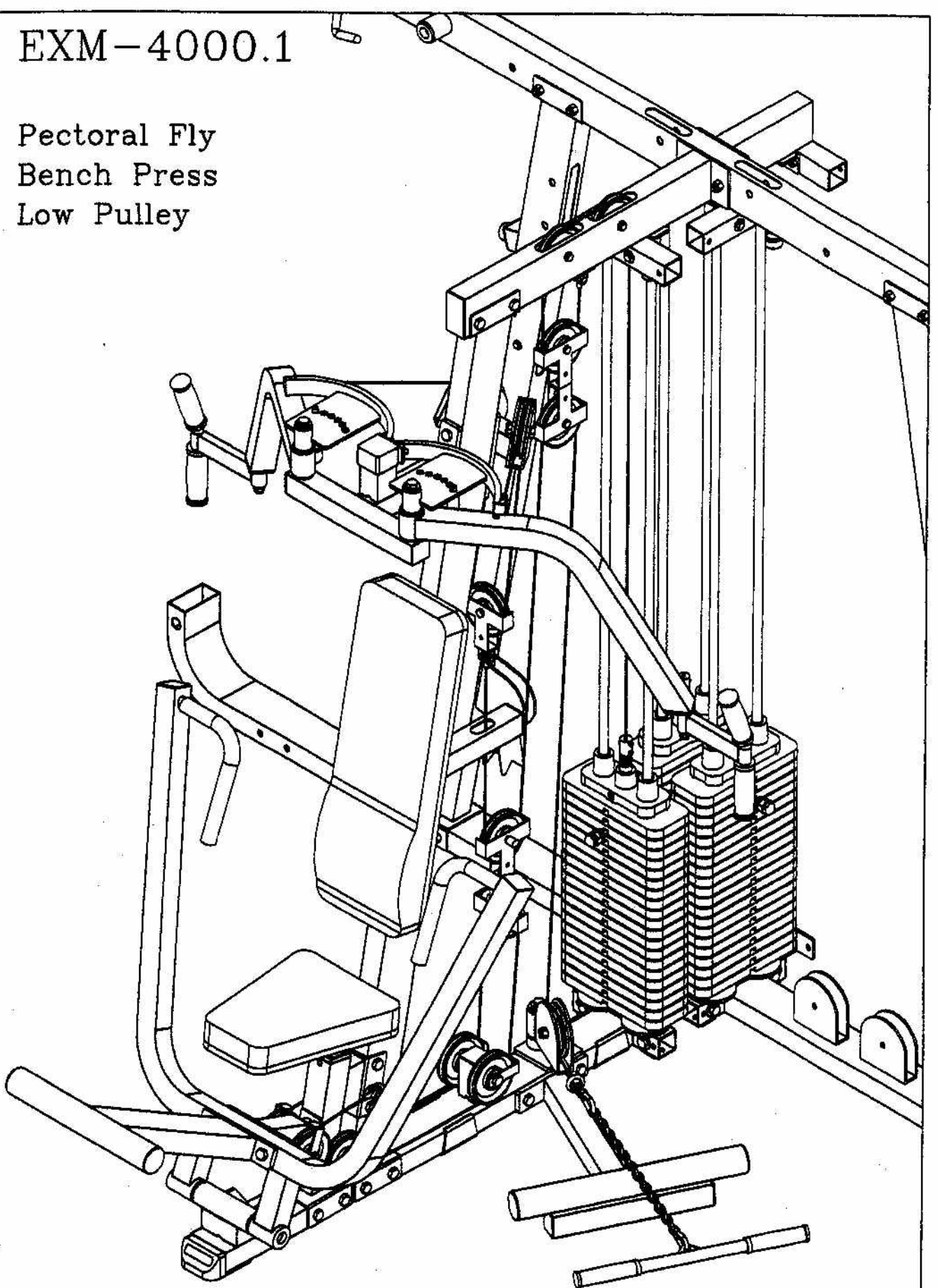

EXM-4000.1

