

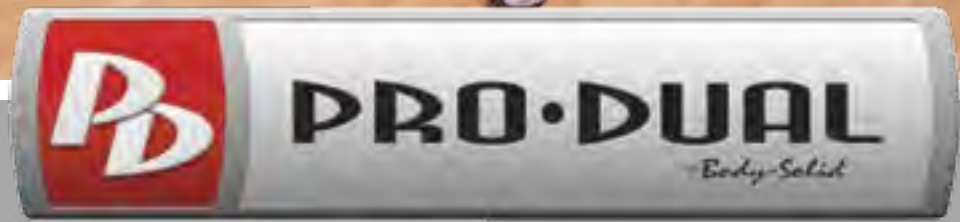

The ultimate strength-training solution for all experience levels. Body-Solid's new modular Commercial Dual equipment line is designed to be smooth and fluid to work in tandem with the body's natural movements, thereby providing a more efficient, more comfortable workout experience for users of all gender, age, size and body type. Best of all, you can buy with confidence, because every Body-Solid home gym is built to last a lifetime and is backed by the strongest warranty in the industry!

Modularity meets modern design aesthetics

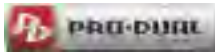



DABB-SF AB & BACK MACHINE

- Dual function oversized 9" diameter adjustable roller pad for comfort in use and proper alignment for both ab and back exercises.
- Counterbalanced resistance arm with 14 adjustable starting points.
- Biomechanically angled seat with 5 gas-assisted adjustable positions is user-adjustable to achieve proper pivot point for exercise.
- 6-position adjustable leg pad/foot brace provides stability for users of all heights.
- Includes a 210 lb. weight stack with a 310 lb. weight stack option.
- Industrially rated, sealed bearings at all pivot points
- Dimensions: 51"W x 43"L x 62"H (130cm x 109cm x 158cm)

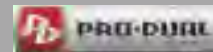

DLEC-SF LEG EXTENSION & CURL MACHINE

- Custom designed biomechanical seat with a 12-position adjustable back pad to properly align users of all sizes.
- Oversized 9" diameter self-adjusting leg pad provides comfort and proper alignment during both leg curls and leg extensions.
- Leg pad has 7 adjustments for both leg curls and leg extensions, providing a greater range of motion during either exercise.
- Pop-pin adjustable thigh hold-down pad comfortable secures user and helps provide support during exercise.
- Includes a 210 lb. weight stack with a 310 lb. weight stack option.
- Counterbalanced leg extension
- Dimensions: 53"W x 40"L x 62"H (135cm x 102cm x 158cm)

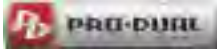

DCLP-SF LEG & CALF PRESS MACHINE **FC**

- Ergonomic recumbent seat with 12 position adjustable back pad accommodates users of all sizes comfortable and safely for both leg press and calf exercises.
- Wide rubber, matted non-skid press plate and conveniently placed handgrips provide added stability during maximum pressing.
- Four bar linkage and oversized pillow block bearings provide smooth, continuous movement throughout each exercise.
- 2:1 weight ratio with a 210 lb. weight stack provides 420 lbs. of resistance. Also available in a 310 lb. weight stack.
- Dimensions: 41"W x 78"L x 77"H (104cm x 199cm x 196cm)

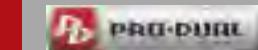

DIOT-SF INNER & OUTER THIGH MACHINE **FC**

- Ergonomically correct forward-facing weight stack provides easy resistance adjustments and user privacy.
- Extra large rotating kneepads provide comfort and support during both the inner and outer thigh movements.
- 9-position seat back adjustments and dual, non-skid foot posts are designed to accommodate users of all sizes.
- Easy to reach pop-pin leg adjustments provide users a greater range of motion.
- Includes a 210 lb. weight stack with a 310 lb. weight stack option.
- Dimensions: 53"W x 40"L x 62"H (135cm x 102cm x 158cm)



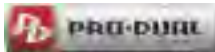

DLAT-SF LAT & MID ROW MACHINE

- No-cable-change design allows user to switch between exercises quickly without adding, connecting or changing cables.
- Oversized 9" diameter thigh pads easily adjust to provide stability during heavy workouts.
- Non-skid foot brace and an extra-long seat pad provide stability and support for mid row exercises.
- Accessory hooks store cable attachments when not in use.
- Includes a 210 lb. weight stack with a 310 lb. weight stack option.
- Dimensions: 33"W x 68"L x 83"H (84cm x 173cm x 211cm)

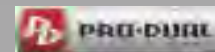

DBTC-SF BICEP & TRICEP MACHINE

- Adjustable arm pad is ergonomically designed to fit multiple users and eliminate unwanted shoulder movements.
- 5-position gas-assisted adjustable seat with back support gives users a comfortable, stable platform to help isolate movement.
- 3-position pivoting handles reduce torque and provide continuous resistance around a natural arc.
- 14 combined adjustments between the bicep and triceps exercises provide users with multiple starting points and greater range of motion.
- Includes a 210 lb. weight stack with a 310 lb. weight stack option.
- Dimensions: 53"W x 40"L x 62"H (135cm x 102cm x 158cm)

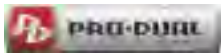

DPCC-SF CABLE COLUMN MACHINE FC

- 18 incremental adjustments for multiple positioning
- User-friendly one handed adjustments on vertical pulley system for quick workouts
- Pivoting quad pulley design allows full range of motion
- Dual handle design for isolateral movements
- Dimensions 36" W x 46" L x 83" H

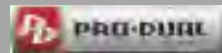

DPEC-SF PEC & REAR DELT MACHINE FC

- Independent arms with 5 adjustable starting positions enable users greater range of motion as well as both unilateral and bilateral arm movements.
- Extra-long 360 degree rotating handles self adjust to the users path of motion for both pec and rear delt exercises.
- Easy, 5-position gas-assisted seat adjustment puts users of any size in proper position.
- Includes a 210 lb. weight stack with a 310 lb. weight stack option.
- Dimensions: 34" W x 57" L x 69" H (86cm x 145cm x 173cm)

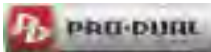

DPLS VERTICAL PRESS & LAT MACHINE **FC**

- Adjustable press arm for full range of motion
- Ergo grip press handles for correct positioning.
- Heavy gauge 2"x4" mainframe construction and aircraft quality cables and pulleys.
- Biomechanically designed for maximum range of motion and outstanding muscle development.
- Dimensions: 78"W x 40"L x 83"H (198cm x 102cm x 211cm)

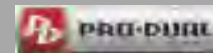

DPRS-SF MULTI PRESS MACHINE **FC**

- Unique 20-position adjustable seat and back pad slide in unison, creating multiple press angles from flat through incline and vertical shoulder press.
- Heavy-duty counterbalanced press bar includes 5 adjustment angles and pillow block bearing pivots for continuously smooth movement.
- Biomechanically designed for maximum chest concentration and outstanding muscle development.
- Multiple press handles provide users of all sizes with different grip angles to create variable exercises to concentrate on distinct areas of the chest and triceps.
- Includes a 210 lb. weight stack with a 310 lb. weight stack option.
- Dimensions: 57"w x 89"L x 62"H (145cm x 226cm x 158cm)

PRO-DUAL **DGYM MODULAR GYM SYSTEM** **FC**

- Continuous welded, factory assembled connections on the weight and station frame provide extra stability along with durability that extends the life of the station.
- Impact-resistant fiberglass reinforced nylon pulleys include precision ground and sealed bearings providing prolonged cable life and smooth movement.
- 11-gauge 2.375" x 4.625" oval tubing on the main frame combined with 3 gauge steel connecting plates and 1/2" diameter connecting bolts provides high strength and durability.
- Two step durable, electrostatically applied metallic powder coat finish with clear coat, provides a high quality, low maintenance finish that is protected from scratching, chipping and fading.
- Spun steel aircraft cables over 2" high density foam, is double stitched and fully supported, guarantee a tear resistant, durable surface for comfort and support.
- High density rubber foam grips and handles provide durability with ergonomically correct gripping surfaces.
- Industrially rated sealed bearings at all major pivot points provide smooth movements and easy adjustments.
- See pages 94-95 for configurations and dimensions



DGYM combination on this page is just one of the thousands of configurations Pro•Dual has to offer. See pg. 94-95 for more options.

Pro•Dual DGYM

Shown with:

DPLS - Vertical Press and Lat

DPCC - Adjustable Cable Column

DLEC - Leg Extension/Leg Curl

DPEC - Pec Dec/Rear Delt

Thousands of configurations to build your own gym!

Start with the base station (DGYM), then chose any combination of four of the following Pro•Dual single stations to complete your package.

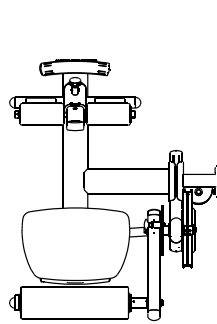
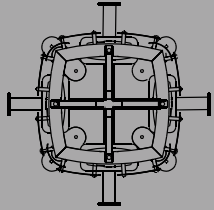

DABB
Ab Crunch/
Back Extension

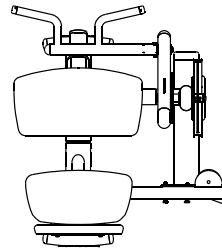

DBTC
Bicep Curl/
Tricep Extension

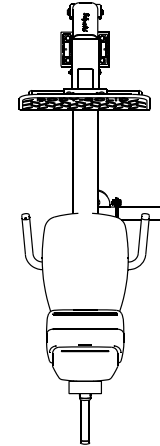

DCLP
Leg Press/
Calf Extension

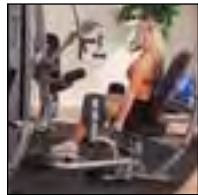
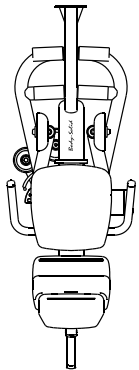

DIOT
InnerThigh/
OuterThigh

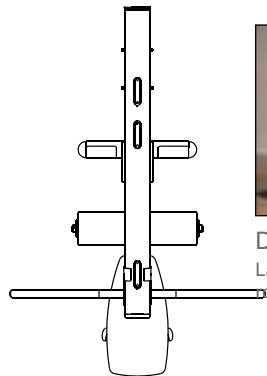

DLAT
Lat Pull-Down/Mid-
row

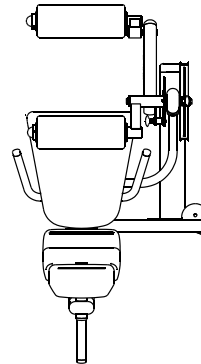

DLEC
Leg Extension/
Leg Curl

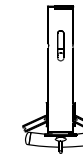

DPCC
Adjustable Cable
Column

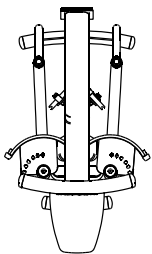

DPEC
Pec Dec/Rear Delt

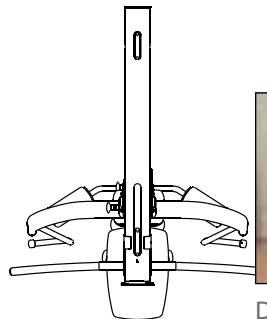

DPLS
Vertical Press and Lat

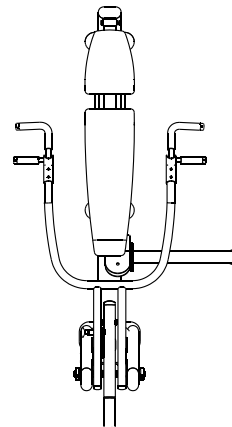

DPRS
Multi-Press

Pro•Dual Single Stations

DABB.... Ab Crunch/Back Extension.....Pg. 88
DBTC.... Bicep Curl/Tricep Extension..Pg. 90
DCLP Leg Press/Calf ExtensionPg. 89
DIOT..... InnerThigh/OuterThighPg. 89
DLAT Lat Pull-Down/MidrowPg. 90
DLEC Leg Extension/Leg Curl.....Pg. 88
DPCC.... Adjustable Cable Column.....Pg. 91
DPEC Pec Dec/Rear Delt.....Pg. 91
DPLS Vertical Press and Lat.....Pg. 92
DPRS Multi-Press.....Pg. 92

Combine any Pro•Dual stations to suit your needs.

Here are four of our most popular DGYM combinations. But don't leave it up to us—there are thousands of combinations to create the gym that's right for you!

DGYMP1 L: 102" W: 131" H: 83"

- DCLP
Leg Press/Calf Extension
- DPLS
Vertical Press and Lat
- DPEC
Pec Dec/Rear Delt
- DLEC
Leg Extension/
Leg Curl

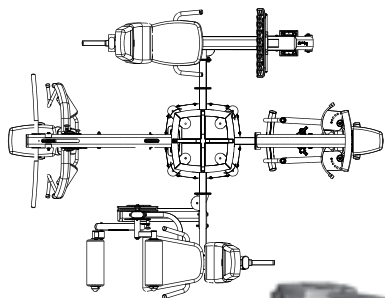

DGYMP2 L: 123" W: 125" H: 83"

- DLEC
Leg Extension/Leg Curl
- DPCC
Adjustable Cable Column

- DPLS
Vertical Press and Lat
- DIOT
Inner Thigh/
Outer Thigh

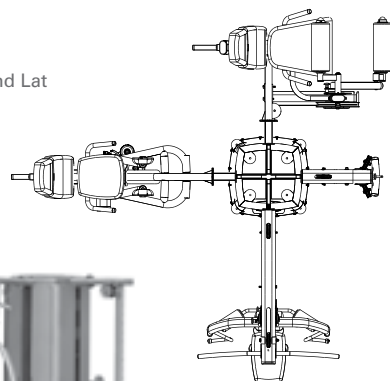

DGYMP3 L: 125" W: 124" H: 83"

- DLAT
Lat Pull-Down/Midrow
- DABB
Ab Crunch/Back Extension
- DCLP
Leg Press/Calf Extension
- DPLS
Vertical Press and Lat

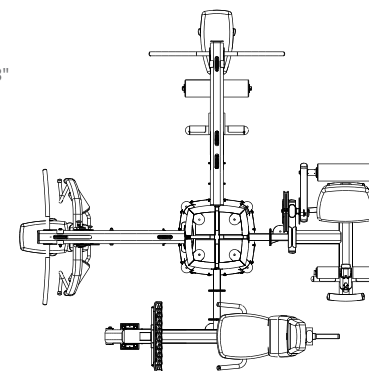

DGYMP4 L: 141" W: 141" H: 83"

- DLAT (two)
Lat Pull-Down/Midrow
- DPEC (two)
Pec Dec/Rear Delt

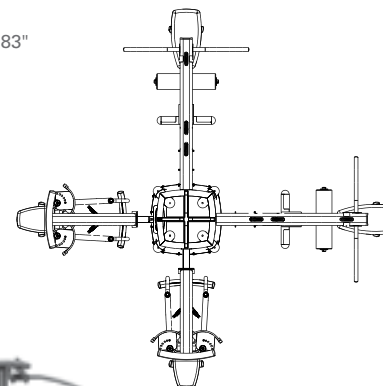

All combinations and renderings on this page are for suggestion purposes. To build your own custom DGYM, visit bodysolidcommercial.com or call 800-833-1227 for more assistance.