

BAKER Tapered Roller Bearing Kit



Installation Instructions



BAKER TAPERED ROLLER BEARING KIT

TABLE OF CONTENTS

1. Introduction and fitment
2. Required parts, tools, and reference materials
3. Included parts
4. Tapered roller bearing exploded view
5. Torque specifications and stock component removal
6. Transmission case preparation
7. Tapered bearing adapter preparation
8. Heating the transmission case
9. Tapered bearing adapter installation
10. Countershaft bearing and main drive gear installation
11. Main drive gear installation
12. Setting up end play in the tapered roller bearings
13. Seal and pulley spacer installation
14. Gearset installation and final steps
15. Terms & conditions
16. Notes

BAKER TAPERED ROLLER BEARING KIT

INTRODUCTION

Baker's tapered roller main drive gear bearing was introduced as the new standard with the GrudgeBox in 2017. It is included with every GrudgeBox and DD7, and this kit is intended to convert a stock H-D 6-speed transmission or an older DD7 to one with a tapered roller bearing. By upgrading the problematic self-aligning main drive gear bearing to a tried-and-true opposing tapered roller bearing pair, you and your motorcycle will stay on the road and out of the shop.

FITMENT

- 2006 – Later Dyna, Factory 6-Speed Transmission or BAKER DD7
- 2007 – Later Softail, Factory 6-Speed Transmission or BAKER DD7
- 2007 – Later Touring, Factory 6-Speed Transmission or BAKER DD7

WARRANTY

This product includes a 2-year, 24,000-mile warranty. All steps in these instructions must be completed as outlined for the warranty to remain valid.

WHAT DO I NEED?

REQUIRED PARTS, TOOLS, & REFERENCE MATERIALS

To install the Tapered Roller Bearing Kit, the following is required:

- Factory Service Manual for your year and model motorcycle
- New primary cover gasket
- Common hand tools (allen wrenches, sockets, retaining ring pliers, etc.)
- Breaker bar, 1/2" drive
- Torque wrenches, 3/8" & 1/2" drive
- 1-3/16" socket, 6 pt.
- Red and blue threadlocker
- Dial indicator
- MAP/Propane gas or heat gun
- Main drive gear & bearing service tool
 - BAKER TOOLA-07
 - H-D equivalent 35316C
- Inner primary race service tool
 - BAKER TOOLB-56
 - H-D equivalent 34902B
- Pulley locking tool
 - BAKER TOOLC-56
 - H-D equivalent 46282
- Pulley nut socket
 - BAKER TOOLD-07
 - H-D equivalent 47910
- Countershaft bearing service tool
 - BAKER TOOLE-07
- Primary drive locking tool
 - H-D-48219 (Touring models)
 - H-D-47977 (Softail/Dyna)
- Primary fluid, 40-46 oz.; see Factory Service Manual
 - BAKER recommends Spectro Heavy Duty Primary Chain Case Oil; R.HDPCO
- Transmission fluid, 32 oz.
 - BAKER recommends Spectro Heavy Duty Platinum 6 Speed Transmission Oil; BD-75140-32

HIGHLY RECOMMENDED ADDITIONAL PART

Baker Drivetrain highly recommends that the automatic chain tensioner be replaced with a Baker Attitude Adjuster (figure 1). Extensive testing and durability miles have proven that our Attitude Adjuster (P/N 177-67K) puts less shear stress load on the motor sprocket shaft and the transmission mainshaft, thereby extending the life of the drivetrain components.



NOTE: DOES NOT FIT 2018-LATER SOFTAILS WITH MID CONTROLS

FIGURE 1 | BAKER ATTITUDE ADJUSTER

WHAT'S INCLUDED IN MY KIT?



- Factory 6-speed main drive gear assembly
- H-D main drive gear, modified, 35122-CD6 (includes bearings and seals)
 - Tapered roller bearing, HR32910J
 - .104" bearing spacer, green, 11620-GB

OR

- BAKER DD7 main drive gear assembly
- DD7 main drive gear, modified, DD7-7M-TB (includes bearings and seals)
 - Tapered roller bearing, HR32910J
 - .106" bearing spacer, blue, 11620-GB



- Countershaft bearing, 8963
 Tapered roller bearing, HR32910J
 Tapered roller bearing adapter, 11610-GB
 Pulley spacer w/ O-ring, 33334-GB | OR568M52
 Main drive gear seal, 12074-67
 85mm beveled internal retaining ring, VHO-334STPA
 .102" bearing spacer, white 11615-GB
 - Extra in CD6 kits only
 .104" bearing spacer, green 11620-GB
 - Pre-installed in CD6 kits, extra in DD7 kits
 .106" bearing spacer, blue 11625-GB
 - Pre-installed in DD7 kits, extra in CD6 kits
 .108" bearing spacer, red 11630-GB
 - Extra in DD7 kits only

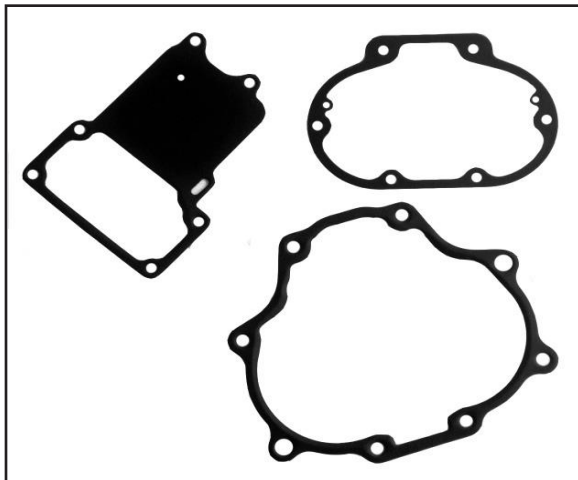

- Bearing door gasket, 35654-67
 Top cover gasket, 34917-06-F
 Side cover gasket, 36805-06-F



- Bearing adapter installation cup, T855-GB

TAPERED ROLLER BEARING EXPLODED VIEW

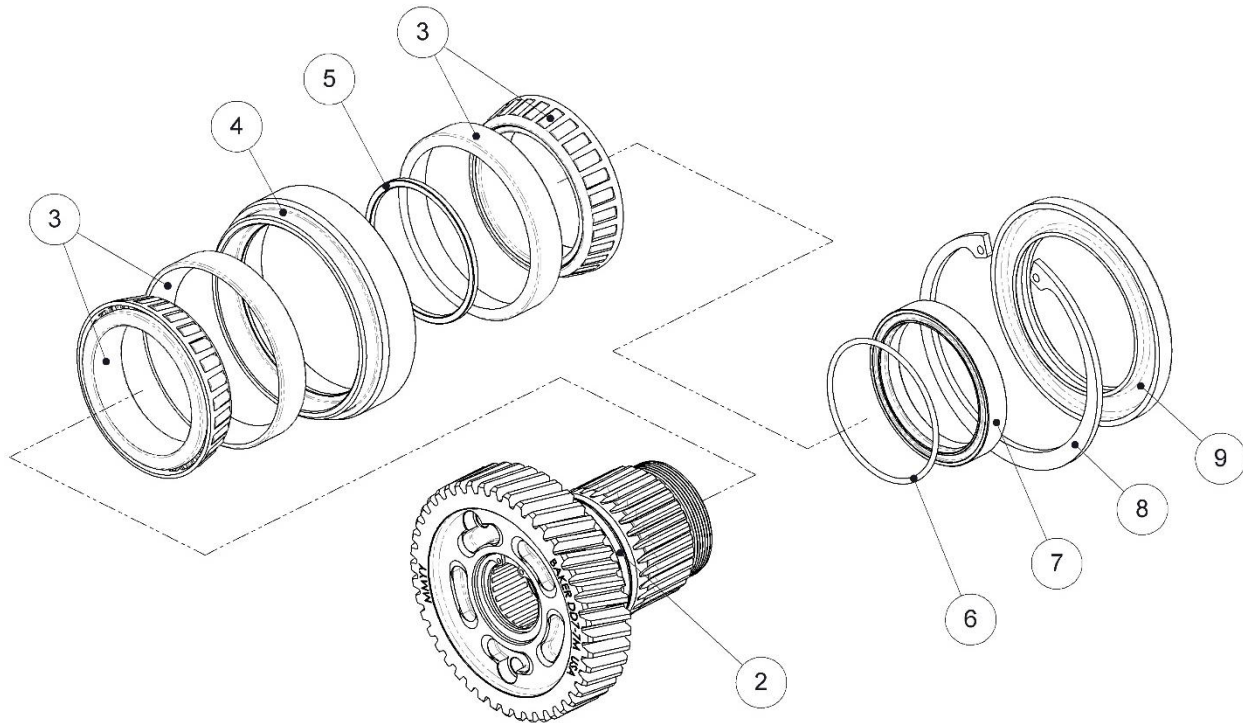

FIGURE 2 | EXPLODED VIEW, TAPERED ROLLER BEARING

ITEM	P/N	QTY	DESCRIPTION
1	DD7-7M-TB	1	7 th gear, mainshaft, BAKER DD7, 44T
	35122-CD6	1	6 th gear, mainshaft, Factory H-D, 44T
2	OR568132	1	O-ring, Buna #132
3	HR32910J	2	Bearing, tapered roller, 50 x 72 x 15mm
4	11610-GB	1	Adapter, tapered roller bearings
5	11615-GB	1	Spacer, tapered roller bearings, .102", white*
	11620-GB	1	Spacer, tapered roller bearings, .104", green*
	11625-GB	1	Spacer, tapered roller bearings, .106", blue**
	11625-GB	1	Spacer, tapered roller bearings, .108", red**
6	OR568M52	1	O-ring, pulley / sprocket spacer, 52mm
7	33334-GB	1	Spacer, pulley / sprocket
8	1302-334PP	1	Retaining ring, beveled internal, 85mm
9	12074-67	1	Seal, main drive gear, 2.380" x 3.375" x .285"

* CD6 kits: .104" spacer (green) is pre-installed on main drive gear, .102" (white) and .106" (blue) spacers are included separately

** DD7 kits: .106" spacer (blue) is pre-installed on main drive gear, .104" (green) and .108" (red) spacers are included separately

INSTALLATION PREPARATION

BEFORE YOU BEGIN

The transmission is a component in the powertrain of your motorcycle. As such, its function is highly dependent on other components in the powertrain to perform as designed. If the clutch, clutch actuator, primary, or shift linkage is worn, tired, or compromised in any way, the transmission will not perform as designed. The process of installing the Tapered Roller Bearing Kit is the perfect time to assess and freshen up these components to ensure the transmission gives you years of trouble-free service.

TORQUE SPECIFICATIONS

THREAD	APPLICATION	TORQUE VALUE	THREADLOCKER
1/4"-20	Side cover, top cover, derby cover, outer primary, VSS, pulley locking plate	132 – 156 in-lb	Blue recommended
5/16"-18	Bearing door, inner primary	22 – 25 ft-lb	Blue recommended
5/16"-24	Shift arm pinch bolt	18 – 22 ft-lb	Blue recommended
9/16"-12	Comp sprocket bolt	See Factory Service Manual	Red required
3/4"-18	Clutch nut	70 – 80 ft-lb	Red required
1-3/4"-20	Pulley/sprocket nut	100 ft-lb, loosen 1 full turn, then 35 ft-lb + 35° – 40°	Red required
9/16"-18	Neutral switch	120 – 180 in-lb	None
3/4"-16	Transmission dipstick	25 – 75 in-lb	None
1/2"-20	Transmission drain plug	14 – 21 ft-lb	None
1/2"-20	Primary drain plug	14 – 21 ft-lb	None

STOCK COMPONENT REMOVAL

Refer to your Factory Service Manual for detailed instructions on how to remove your stock gearset, main drive gear, shifter pawl, and speed sensor from the transmission case. Softails, Dynas, and Touring models are all different configurations and require different methods to accomplish the removal. Ensure that you have the correct Factory Service Manual for your year and model of motorcycle.



THE COUNTERSHAFT CUP BEARING MUST BE REMOVED FROM THE TRANSMISSION CASE AT THIS TIME. USE BAKER TOOLE-07 OR EQUIVALENT.

A REPLACEMENT IS PROVIDED IN YOUR KIT, BUT IT WILL BE INSTALLED AFTER THE TAPERED BEARING ADAPTER.

BERT TIPS:

Apply heat to the comp sprocket bolt head prior to removal. Failure to do so could result in mangled sprocket shaft threads and halt the installation of your tapered roller bearing.

Remove the dipstick prior to removing the gearset from the transmission case. Failure to do so will result in a broken dipstick and a trip to the nearest H-D dealer.

BEFORE INSTALLING YOUR TAPERED ROLLER BEARING

TRANSMISSION CASE PREPARATION

Surgically clean the left side of the transmission case in preparation for installing the new DD7 main drive gear and gearset. This surgical cleansing includes the main drive gear and countershaft bearing boss areas, the three inner primary mount bosses, and the shifter pawl boss. See figure 3.

The bearing boss areas must be clean to ensure that no dirt or debris scores the bearing bores during the removal of old bearings and installation of new ones. The three inner primary mount bosses need to be clean so that the tool plate registers flat on the left side transmission case.



FIGURE 3 | SURGICALLY CLEAN THE LEFT SIDE OF THE TRANSMISSION CASE IN THE AREAS INDICATED ABOVE

CAUTIONARY NOTE

There are special tools available from other manufacturers that remove and install the countershaft cup bearing, but they all have one fundamental error – they push on the inside of the cup (from right to left in the motorcycle) for removal and installation. THIS IS WRONG! Cup bearings require that the installation force be applied to the outside of the cup (from left to right). BAKER TOOLE-07 (sold separately) applies removal and installation forces in the proper direction.



VISIT THE BAKER DRIVETRAIN YOUTUBE CHANNEL AND WATCH [CLASS #4](#). IN THIS VIDEO, WE SHOW YOU HOW TO INSTALL THE TAPERED ROLLER BEARING ADAPTER AND MAIN DRIVE GEAR. WATCHING THE VIDEO AHEAD OF TIME WILL GIVE YOU THE TIPS, TRICKS, AND KNOWLEDGE TO ENSURE A PROPER INSTALLATION.

INSTALLING THE TAPERED BEARING ADAPTER

TAPERED BEARING ADAPTER INSTALLATION

1. Apply a thin coating of oil to the outer diameter of the tapered bearing adapter. Do the same to the main drive gear bearing bore in the transmission case.
2. Use the aluminum cup provided in your kit in combination with the main drive gear installation tool (BAKER TOOLA-07 or H-D equivalent 35316C) to install the tapered bearing adapter. Refer to the section on installing the main drive gear bearing in your Factory Service Manual. The tool will be set up in a similar manner, but with a few key differences. The tapered bearing adapter will take the place of the traditional main drive gear bearing, and the included aluminum cup will take the place of the bearing driver. See figures 4 and 5 for the proper tool setup.

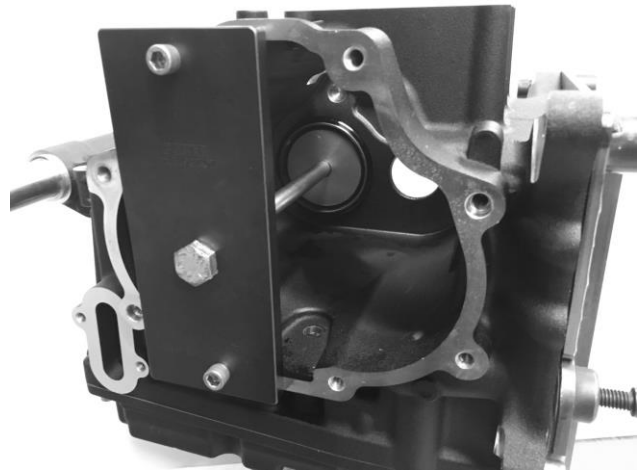

FIGURE 4 | TAPERED BEARING ADAPTER TOOL SETUP, RIGHT SIDE VIEW



FIGURE 5 | TAPERED BEARING ADAPTER TOOL SETUP, LEFT SIDE VIEW

3. Assemble the tool with the stepped down portion of the tapered bearing adapter facing toward the inside of the case; see figure 6. **Make sure that the adapter is square to the bearing bore** and snug the tool nut. If the adapter is not square to the bore, loosen the nut and realign the adapter.

Leave the nut snug. Do not press the adapter into the case.



FIGURE 6 | TAPERED BEARING ADAPTER ORIENTATION IN CASE, TOP VIEW

INSTALLING THE TAPERED BEARING ADAPTER

- The tapered bearing adapter has a tighter press fit into the transmission case than the stock bearing. To ensure successful installation of the tapered bearing adapter and longevity of the installation tool, you must heat the transmission case as shown in figure 7. Use a MAP/propane torch or a heat gun as shown in figure 8.

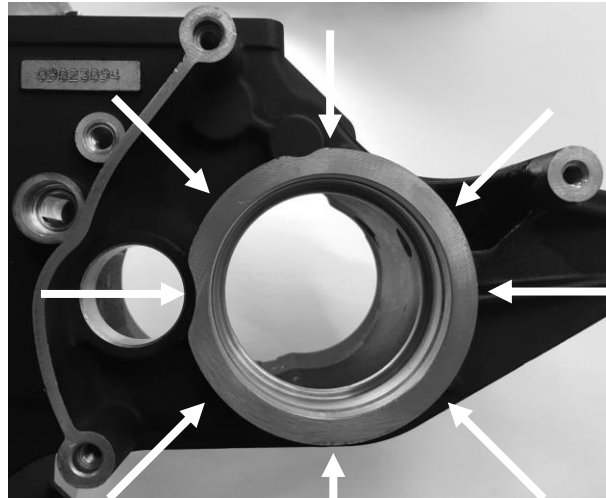

FIGURE 7 | APPLY HEAT AROUND THE MAIN DRIVE GEAR BEARING BOSS AREA

- Apply heat evenly around the boss of the main drive gear bearing bore from the outside of the case as shown in figure 7. **DO NOT** heat the boss from the inside of the case and keep heat away from the tapered bearing adapter that is staged and ready for installation. The bearing bore boss should be heated to at least 200°F. BAKER recommends using an infrared thermometer to verify that the case is adequately heated; see figure 9.



FIGURE 8 | USE MAP/PROPANE GAS OR A HEAT GUN TO HEAT THE CASE

BERT TIP:

You may see some discoloration where the case is heated. Restore color by rubbing a little bit of WD-40® or another thin oil into the powdercoat.



FIGURE 9 | USE AN INFRARED THERMOMETER TO VERIFY THAT THE CASE IS HEATED TO AT LEAST 200° F

INSTALLING THE TAPERED BEARING ADAPTER

- Immediately after the case is heated, tighten the tool nut to draw the tapered bearing adapter into the case. This operation must be done quickly with no interruptions while the case is hot. If the support plate on the other side of the case starts to bend, stop, loosen the nut slightly, and reheat the case. The aluminum cup should be about flush with the bearing boss when the tapered bearing adapter is fully seated; see figure 10.

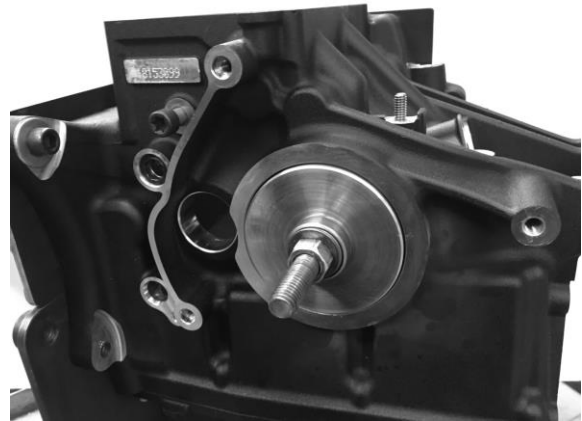

FIGURE 10 | TAPERED BEARING ADAPTER FULLY SEATED IN CASE

BERT TIP:

Do not over tighten the nut after the tapered bearing adapter is bottomed out. Doing so may damage the tool or the transmission case.

- Remove the installation tool. You will know the tapered bearing adapter is seated into the bore when the beveled retaining ring groove is fully visible; see figure 11.



FIGURE 11 | TAPERED BEARING ADAPTER VISUAL INSPECTION

- Install the beveled retaining ring (VHO-334STPA) with the bevel facing outward. Make sure that the retaining ring fully seats into the groove; see figure 12.

**BEVEL ON RETAINING RING
MUST FACE OUTWARD**

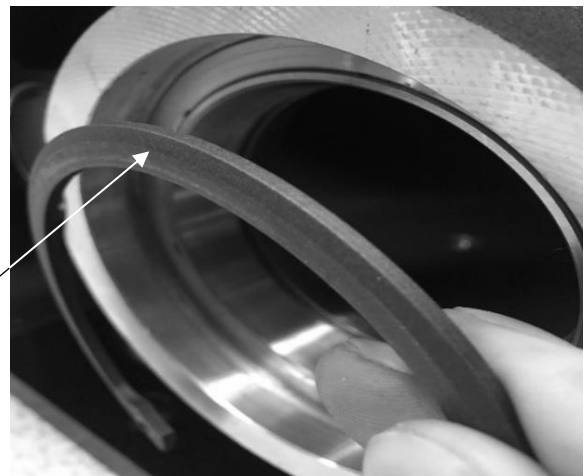

FIGURE 12 | BEVELED RETAINING RING WITH BEVEL FACING OUTWARD

INSTALLING THE MAIN DRIVE GEAR

COUNTERSHAFT BEARING INSTALLATION

1. It is now time to install the new countershaft bearing that was provided in your kit. It is important that this step be done **AFTER** installing the tapered bearing adapter. This is to avoid cooking your new countershaft bearing while heating the case in that step.
2. Wipe out the countershaft bearing bore with a clean rag. Apply a thin coating of oil to both the bearing bore and the outer diameter of the countershaft bearing.
3. Use a countershaft bearing tool (BAKER TOOLE-07 or equivalent) to press the bearing into the transmission case. You want to press on the outside of the 'cup', just as you did during removal. See the appropriate tool instructions and your Factory Service Manual for details.

MAIN DRIVE GEAR INSTALLATION

1. Before installing the main drive gear, apply a thin coating of transmission oil to the tapered bearing races and the main drive gear O-ring; see figure 13. A thicker oil could give you a false reading when checking endplay.
2. Each kit comes with three spacers for setting up end play in the tapered roller bearings. The most commonly used spacer is pre-installed on the main drive gear (figure 14):

CD6: .104" (green)
DD7: .106" (blue)

Two extra spacers are included in each kit for cases in which bearing end play is outside of the acceptable range with the pre-installed spacer.

CD6: .102" (white) & .106" (blue)
DD7: .104" (green) & .108" (red)

Apply a thin coating of transmission oil to the main drive gear O-ring each time you change the spacer.

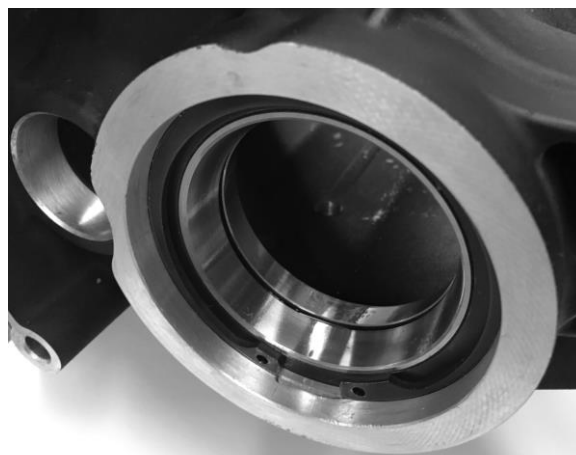

FIGURE 13 | LIGHTLY OIL BEARING RACES AFTER INSTALLING THE TAPERED BEARING ADAPTER



FIGURE 14 | MAIN DRIVE GEAR WITH PRE-INSTALLED SPACER AND ONE OF THE EXTRAS; LUBE O-RING

INSTALLING THE MAIN DRIVE GEAR

- Follow the Factory Service Manual to install the main drive gear using BAKER TOOLA-07 or H-D equivalent 35316C. If the H-D equivalent tool is used, you will need to use pulley spacer 33334-GB from your kit for extra spacing while pressing the tapered bearings together.

If you need to use the pulley spacer (33334-GB), temporarily remove the O-ring. Remember to re-install it after the end play is set.

- Gently slide the assembled main drive gear through the case. Take the loose tapered roller bearing (HR32910J) and slide it over the main drive gear, letter side facing out. Slide the pulley spacer onto the gear if needed (O-ring groove facing bearing), followed by the remaining press tools; see figure 15.

BERT TIP:

Apply pressure to the main drive gear during this step by reaching your left hand through the top of the transmission case. Failure to do so (i.e. allowing the gear to flop around) will damage the bearing races.

- With the tooling installed, snug the assembly by hand while making sure the installation tool cup is properly aligned and not skewed to the side of the tapered bearing. Hold the bolt on the inside of the case using the proper socket and ratchet. Tighten the main drive gear tooling on the primary side of the bike until it is fully seated and tight. Refer to the main drive gear tool instructions and figure 16.



FIGURE 15 | IF USING H-D TOOLING, THE INCLUDED PULLEY SPACER IS NEEDED TO EXTEND THE LENGTH OF THE INSTALLATION CUP



FIGURE 16 | INSTALLING THE MAIN DRIVE GEAR

INSTALLING THE MAIN DRIVE GEAR

6. Do not remove the installation tool yet; leave everything tight. Measure the amount of endplay in the main drive gear assembly using a dial indicator with .0005" increments as shown in figure 17. **Total axial end play (pulling / pushing on the gear) must be between .0005" and .002"**. It is extremely important that your bearing end play is within this range, as anything too tight or too loose may lead to transmission failure.

Measuring end play is tricky. The end play measurement can easily be skewed if radial or rotational forces are applied, so try to keep movement in the axial direction (parallel to the mainshaft). A correctly set up tapered roller bearing should be very tight. When you think your measurement is between .0005" – .002", try spinning the main drive gear. If it spins freely with no drag, setup is complete and you may proceed to the next step.

Watch [Class #4](#) on the *BAKER Drivetrain* YouTube channel for a video tutorial on setting up end play in the main drive gear bearing.



FIGURE 17 | CHECKING AXIAL END PLAY IN THE MAIN DRIVE GEAR TAPERED ROLLER BEARING

CD6 Spacers

Pre-Installed: .104" (green)
Extra: .102" (white)
.106" (blue)

DD7 Spacers

Pre-Installed: .106" (blue)
Extra: .104" (white)
.108" (red)



IF YOUR SETUP IS TOO TIGHT (UNDER .0005"), REMOVE THE MAIN DRIVE GEAR FROM THE CASE USING THE PROPER TOOLING. REMOVE THE O-RING FROM THE 'SNOUT' OF THE MAIN DRIVE GEAR AND REPLACE THE PRE-INSTALLED SPACER WITH A THICKER ONE (SEE ABOVE FOR SPACER COLOR CODES). REPLACE THE O-RING AND GO BACK TO STEP 4.



IF YOUR SETUP IS TOO LOOSE (UNDER .002"), REMOVE THE MAIN DRIVE GEAR FROM THE CASE USING THE PROPER TOOLING. REMOVE THE O-RING FROM THE 'SNOUT' OF THE MAIN DRIVE GEAR AND REPLACE THE PRE-INSTALLED SPACER WITH A THINNER ONE (SEE ABOVE FOR SPACER COLOR CODES). REPLACE THE O-RING AND GO BACK TO STEP 4.

7. Remove the tooling used to install the main drive gear along with pulley spacer if you had to use it. If necessary, reinstall the O-ring (OR568M52) that you removed from the pulley spacer in step 4.

INSTALLING THE MAIN DRIVE GEAR

- Put some transmission fluid on the outer diameter and O-ring of the pulley spacer. Install it onto the main drive gear with the O-ring facing inward (toward the bearing); see figure 18.



FIGURE 18 | INSTALLING THE PULLEY SPACER AND THE MAIN DRIVE GEAR SEAL

- Put some transmission fluid on the lip of the main drive gear seal and install it. Make sure the seal is flush with the transmission case all the way around the bearing boss; see figure 19.

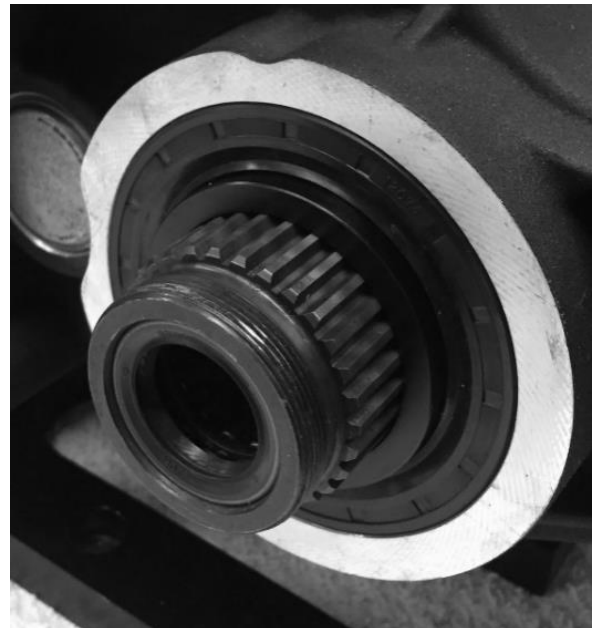

FIGURE 19 | MAIN DRIVE GEAR SEAL INSTALLED FLUSH WITH CASE

FINISH LINE

GEARSET INSTALLATION

1. The time has come to stuff the gearset back into the transmission case. Before that is done, take time to ensure no debris or tarantulas have found their way into the case. Check that the two hollow dowels are still located in the bearing door and replace the bearing door gasket with the one provided in this kit.
2. Generously apply transmission fluid to the last 6" of the mainshaft, end of the countershaft, new countershaft bearing, tapered roller bearings, and the bearings/seal in the main drive gear.
3. Follow your Factory Service Manual or DD7 Installation Instructions to re-install the stock H-D or BAKER DD7 gearset and side cover. Be sure to replace the side cover gasket with the one provided in this kit.

TRANSMISSION FLUID

4. Re-install the transmission drain plug and torque it to 14 – 21 ft-lb. Re-install the transmission dipstick and torque it to 25 – 75 in-lb.
5. Put 32 oz. transmission fluid (75-85W140 synthetic gear oil) into the transmission by pouring it through the top cover cavity onto the main drive gear and shifter pawl. Make sure to coat as much of the gearset components as possible with the fluid.
6. Re-install the top cover with the new gasket provided.

FINAL STEPS

7. Button up the primary, exhaust, shift linkage, and floorboards/footpegs per your Factory Service Manual. Make sure to re-install the primary drain plug and fill the primary with fluid.
8. You have successfully completed the installation of your tapered roller bearing kit. Be observant of basic transmission function and overall vehicle operation during the first 20 miles. Check for leaks after your first ride. Provided there are no issues, give 'em hell and enjoy your new BAKER main drive gear bearing.

TERMS & CONDITIONS

ORDERS

Orders can be pre-paid using VISA, MasterCard, American Express, and Discover or via wire transfer (\$30 wire transfer fee applies). All orders not pre-paid will be sent C.O.D. certified check or money order only unless pre-approved for company check acceptance. Any orders from outside the USA must be pre-paid in US funds via wire transfer (\$30 transfer fee applies). Prices shown are F.O.B. Haslett, MI. BAKER™ ships via UPS Ground or USPS Parcel Post for all orders. UPS air shipment or USPS Priority/ Express services are available upon request. Customer is responsible for all shipping charges unless otherwise arranged at the time of sale.

CUSTOMER SUPPORT

For any installation or service questions, please contact our BAKER technical department: 1-517-339-3835.

LIMITED WARRANTY

NOTE: Warranty card must be returned within 45 days of purchase for your warranty to be valid.

BAKER™ transmission assemblies and transmission builder 's kits, are guaranteed to the original purchaser to be free of manufacturing defects in materials and workmanship for a period of 5 years from the date of purchase or up to 50,000 miles, whichever occurs first. All other BAKER products are guaranteed to the original purchaser to be free of manufacturing defects in materials and workmanship for a period of 2 years from the date of purchase or up to 24,000 miles, whichever occurs first, except for the following; Warranty does not cover clutch plate wear, throw out bearing failures or mainshaft breakage due to improper clutch nut installation.

Electrical components carry a 30-day warranty; cosmetic finishes (chrome plating, hard anodizing, powder coating) are covered for 60 days. Certain promotional products may carry a shorter warranty as specified at the time of purchase. If the product is found by BAKER to be defective, such products will, at the option of BAKER, be replaced or repaired at cost to BAKER.

In the event warranty service is required, the original purchaser must call or write BAKER immediately with a description of the problem. If it is deemed necessary for BAKER to make an evaluation to determine whether the transmission assembly or transmission kit or accessory is defective, the entire transmission assembly, whether originally purchased as an assembly or kit, must be properly packaged and returned prepaid to BAKER with a copy of the original purchase invoice. If after evaluation by BAKER a defect in materials and/or workmanship is found, BAKER will, at their option, repair or replace the defective part of the assembly.

RETURNS AND EXCHANGES

Any merchandise returned for any reason (exchange, credit or modification) must be accompanied by a Return Goods Authorization (RGA) number or it will be refused. Call BAKER to obtain this number prior to returning goods for any reason. There is a 15% re-stocking fee for all returned items.

BAKER is not liable for any shipping.

ADDITIONAL WARRANTY PROVISIONS

NOTE: Limited warranty does not cover labor or other costs or expenses incidental to the repair and or replacement of BAKER products.

This warranty does not apply if one or more of the following situations is judged by BAKER to be relevant: BAKER OEM transmissions ; (these are subject to the OEM manufacturers warranty only), Improper installation , accident, modification (including but not limited to use of unauthorized parts, transmission oils or lubricants), racing, high performance application, mishandling, misapplication, neglect (including but not limited to improper maintenance), or improper repair.

BAKER shall not be liable for any consequential or incidental damages arising out of or in connection with a BAKER transmission assembly, transmission kit, component or part. Consequential damages shall include without limitation, loss of use, income or profit, or losses sustained as the result of injury (including death) to any person or loss of or damage to property.

BAKER transmissions, transmission kits and accessories are designed exclusively for use in American V-Twin motorcycles. BAKER shall have no warranty or liability obligation if BAKER parts are used in any other application.

If it is determined that a BAKER product has been disassembled during the warranty period for any reason, this limited warranty will no longer apply unless you were instructed to do so by a BAKER Drivetrain technician for diagnostic purposes.

TERMS & CONDITIONS

DISCLAIMER

The words Harley and H-D are registered trademarks and are for reference only. Use of H-D model designations and part numbers are for reference only. BAKER Drivetrain has no association with, and makes no claim against, these words, trademarks, or companies.

It is the sole responsibility of the user to determine the suitability of this product for his or her use, and the user shall assume all legal, personal injury risk and liability and all other as well as all other obligations, duties and risks associated therewith.

NOTES