



DD7 TRANSMISSION KIT

TABLE OF CONTENTS

1. About your new DD7
2. Features and gear ratios
3. Required parts, tools, and reference materials
4. Included parts
5. DD7 gearset layout
6. Bearing door exploded view
7. Bearing door Parts list
8. Gearset exploded view
9. Gearset parts list
10. Tapered roller bearing exploded view and parts list
11. Shift system exploded view and parts list
12. Torque specifications and stock component removal
13. Transmission case preparation
14. Tapered bearing adapter preparation
15. Heating the transmission case
16. Tapered bearing adapter installation
17. Countershaft bearing and main drive gear installation
18. Main drive gear installation
19. Setting up end play in the tapered roller bearings
20. Seal and pulley spacer installation
21. Shifter pawl installation and case clearance check
22. Case clearance check
23. Gearset installation
24. Finish line and ECM re-flash
25. Terms & conditions
26. Transmission oil change log
27. General maintenance log

ABOUT YOUR NEW DD7

INTRODUCTION

The BAKER DD7 was designed with performance in mind. We added a 7th gear pair that enables the motorcycle to make full use of the power being put out by the motor. 1st gear is shorter to help you get off the line with ease. The gear ratios are tighter, producing smooth, crisp, continuously pulling acceleration from 1st all the way through 7th gear. No more RPM drops that take you out of the powerband. 1st – 3rd gears are optimized for strength while 4th – 7th gears are optimized for cruising, with 7th gear being a direct-drive 1:1 gear ratio.

FITMENT

- 2006 - 2017 Dyna
- 2007 - Later Softail & Touring Models (Except 2023-2024 CVO, 2024 Street Glide and 2024 Road Glide)

BREAK-IN

The DD7 requires no break-in schedule. However, we do recommend that you take it easy for the first 20 miles to confirm that there are no issues related to basic function of the transmission and the reassembly of the motorcycle. You will notice that the transmission will shift smoother and operate quieter after about 2500 miles. Like any machine, scheduled oil changes are key to years of trouble-free service. Log your transmission oil changes at the recommended intervals on page 26. General maintenance can be logged on page 27.

FLUIDS

The DD7 requires 28-32 oz. of transmission fluid. We recommend Spectro 6-Speed transmission oil that has long chain polymers that stand up to the harsh environment that this high-performance transmission can deliver. Please follow the recommended oil change intervals on page 26 and document your transmission service history. The exception to the stated intervals is winter storage. If the bike is stored in an environment that has significant temperature fluctuations, there will be water condensation inside the transmission. The oil should be changed immediately when it comes out of storage and is put back into service.

WARRANTY

This product includes a 5-year, 50,000-mile warranty. All steps in these instructions must be completed as outlined for the warranty to remain valid.

FEATURES AND GEAR RATIOS

FEATURES

- 7-Speed Direct Drive design.** The 7th gear ratio of the DD7 is 1:1, which is equivalent to the stock transmission 6th gear ratio. We added another gear on the bottom end and tightened up the gear ratios throughout the rest of the gearset. A shorter first gear ratio (numerically higher) will help you when taking off from a stop and during slow speed maneuvering. More efficiently spaced gear ratios will keep you riding in the power band.
- Precision ground gears.** All BAKER gears are hobbed and then heat treated, which hardens them to 58-62 Rockwell C. The final gear tooth form is then precision ground with diamond coated tooling. This extra step ensures quiet operation and allows for tighter control of gear backlash.
- Straight cut 2nd & 3rd gears.** While the stock gearset uses a straight cut 1st gear and helical 2nd - 6th, the DD7 uses straight cut 2nd and 3rd gears with helical 1st and 4th - 7th. The largest amount of torque is put to the ground in 2nd and 3rd gear, and straight cut gears can handle that power. 1st gear has a small helix angle to help mitigate rattle while 4th - 7th gears have a larger helix angle to ensure quiet operation in your cruising gears.
- Tapered roller main drive gear bearing.** We replaced the problematic self-aligning stock main drive gear bearing with a tried-and-true opposing tapered roller bearing pair. Say goodbye to main drive gear bearing failures as you keep your motorcycle on the road and out of the shop.
- Smooth shift system.** The DD7 features a frictionless linear detent system that allows for smooth, crisp shifts. It's easy to find neutral with a secondary detent in the neutral position between 1st and 2nd (1-N-2-3-4-5-6-7). The shift drum utilizes a fixed spindle design for low inertia indexing. Tighter radial gaps in the male-female dog tooth interactions reduce throttle lag and gear clunk noise. All of these features work together to provide smooth, quiet, effortless shifting.
- Billet bearing door.** The trap door is machined out of billet 6061-T6 aircraft grade aluminum. Roller bearings that are 28% wider than stock are pressed in and retained by a cold rolled 1045 steel plate, rather than the stock snap rings. This gets rid of the 'ghost lever' feeling and the bearings can handle much more power without breaking a sweat.

GEAR RATIOS

DD7	Stock H-D
1 st – 3.76	1 st – 3.34
2 nd – 2.75	2 nd – 2.31
3 rd – 2.06	3 rd – 1.72
4 th – 1.55	4 th – 1.39
5 th – 1.27	5 th – 1.19
6 th – 1.10	6 th – 1.00
7 th – 1.00	

WHAT DO I NEED?

REQUIRED PARTS, TOOLS, & REFERENCE MATERIALS

To install the DD7 Transmission Kit, the following is required:

- Factory Service Manual for your year and model motorcycle
- Common hand tools (allen wrenches, sockets, retaining ring pliers, etc.)
- Breaker bar, 1/2" drive
- Torque wrenches, 3/8" & 1/2" drive
- 1-3/16" socket, 6 pt, 1/2" drive
- Red and blue threadlocker
- A new primary cover gasket
- Dial indicator (.0005" increments)
- MAP/Propane gas or heat gun
- Main drive gear & bearing service tool
 - BAKER TOOLA-07
 - H-D equivalent 35316C
- Inner primary race service tool
 - BAKER TOOLB-56
 - H-D equivalent 34902B
- Pulley locking tool
 - BAKER TOOLC-56
 - H-D equivalent 46282
- Pulley nut socket
 - BAKER TOOLD-07
 - H-D equivalent 47910
- Countershaft bearing service tool
 - BAKER TOOLE-07
- Primary drive locking tool
 - H-D-48219 (Touring models)
 - H-D-47977 (Softail/Dyna)
- Primary fluid, 40 oz. (Touring models) or 46 oz. (Softail/Dyna)
 - BAKER recommends Spectro Heavy Duty Primary Chain Case Oil; R.HDPCO
- Transmission fluid, 28-32 oz.
 - BAKER recommends Spectro Heavy Duty Platinum 6 Speed Transmission Oil; BD-75140-32

WARRANTY

This product includes a 5-year, 50,000-mile warranty. All steps in these instructions must be followed carefully for the warranty to remain valid.

HIGHLY RECOMMENDED ADDITIONAL PART

Baker Drivetrain highly recommends that the automatic chain tensioner be replaced with a Baker Attitude Adjuster (figure 1). Extensive testing and durability miles have proven that our Attitude Adjuster (P/N 177-67A-A) puts less shear stress load on the motor sprocket shaft and the transmission mainshaft, thereby extending the life of the drivetrain components.



FIGURE 1 | BAKER ATTITUDE ADJUSTER

NOTE: DOES NOT FIT 2018-LATER SOFTAIL

WHAT'S INCLUDED IN MY KIT?



DD7 gearset w/ shift system
5/16"-18 SHCS, stainless, 73497
Washers, stainless, 6100



Shifter pawl, 555-07-A
Shifter pawl washer, 6497HW-HD
Shifter pawl retaining ring, 68010
Shifter pawl seal, 11000101



Countershaft bearing, 8963
Tapered roller bearing, HR32910J
Tapered roller bearing adapter, 11610-GB
Pulley spacer w/ O-ring, 33334-GB | OR568M52
Main drive gear seal, 12074-67
85mm beveled internal retaining ring, VHO-334STPA
.104" bearing spacer, 11615-GB, green (shown)
.106" bearing spacer, 11620-GB, blue (pre-installed)
.108" bearing spacer, 11625-GB, red (shown)

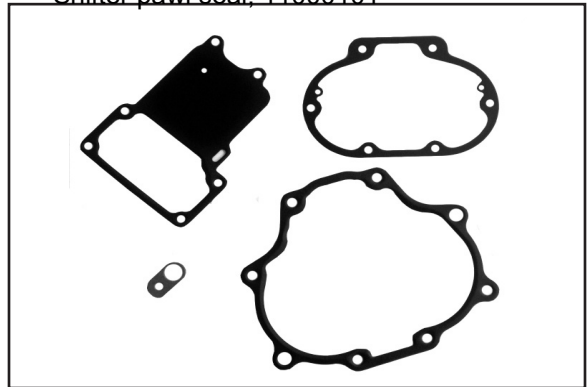

Bearing door gasket, 35654-67
Top cover gasket, 34917-06-F (shown)
25700453 (M8)
Side cover gasket, 36805-06-F
Speed sensor spacer, 132-56R



Bearing adapter installation cup, T1855-GB
Inner primary bearing, P205PP-H
Inner primary bearing seal, 25X52X07ADL



Side cover emblem, DD7-108

DD7 GEARSET LAYOUT

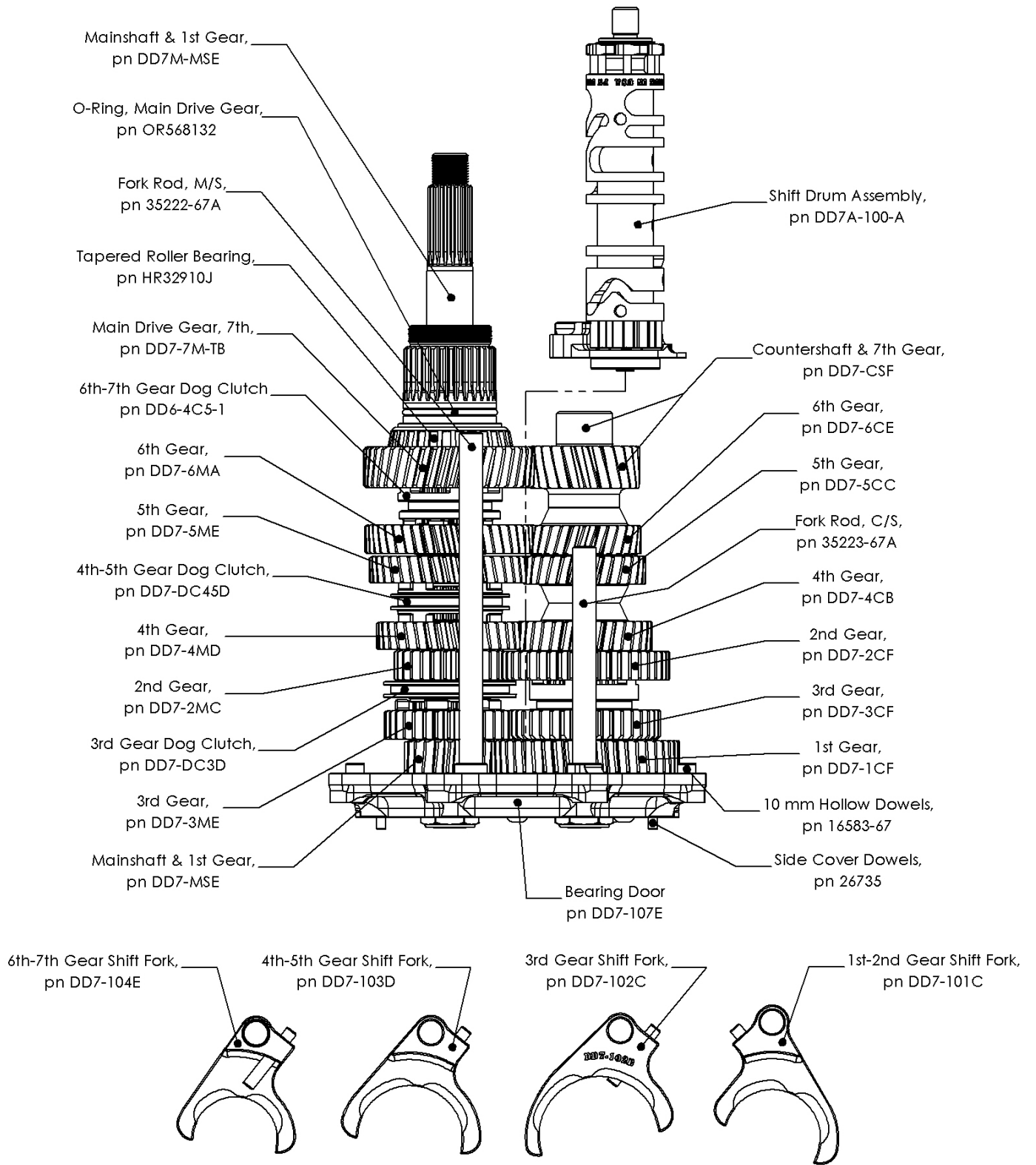

FIGURE 2 | GEARSET LAYOUT

BEARING DOOR EXPLODED VIEW

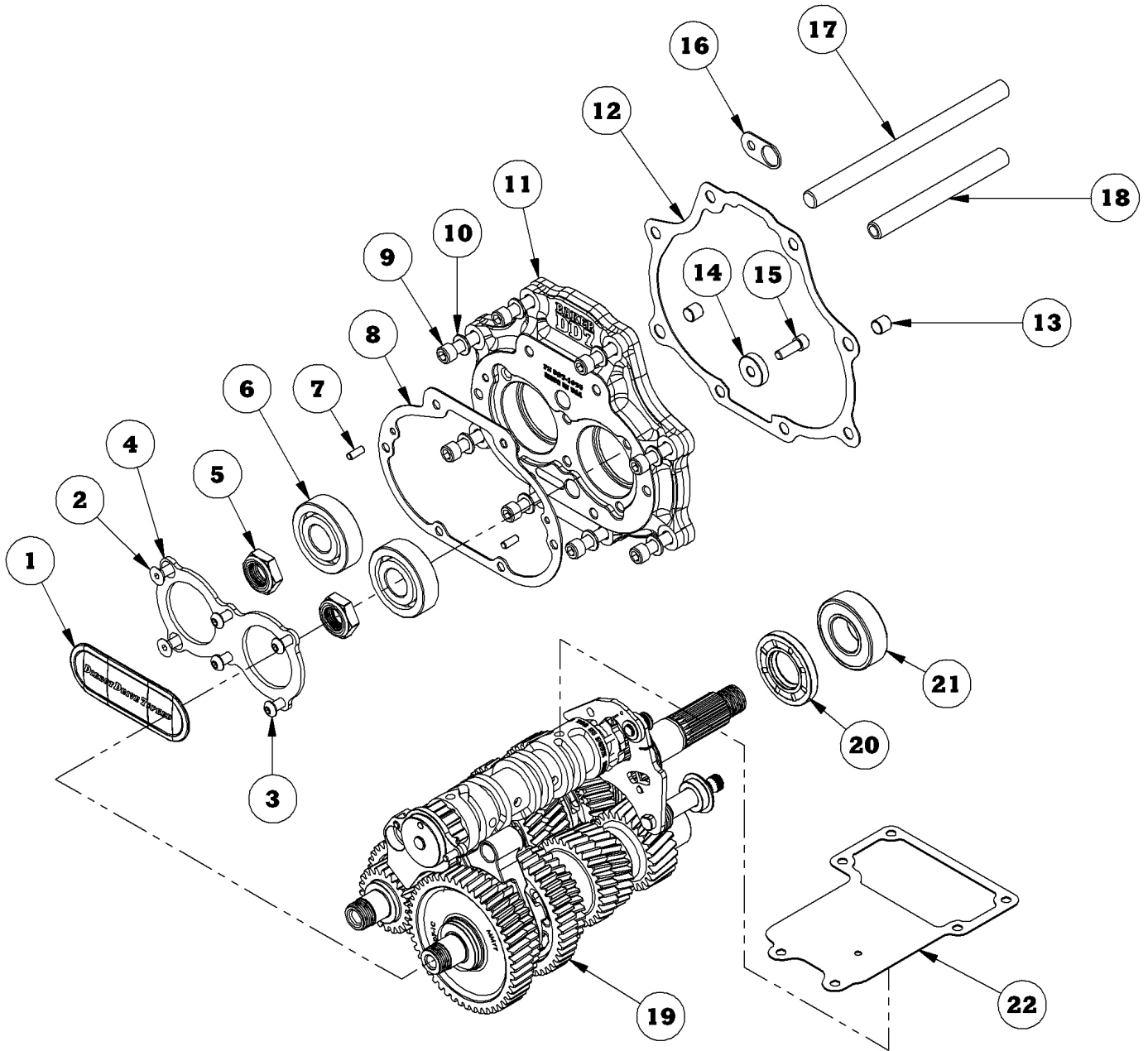

FIGURE 3 | EXPLODED VIEW, BEARING DOOR

BEARING DOOR PARTS LIST

ITEM	P/N	QTY	DESCRIPTION
1	DD7-108	1	Emblem, side cover
2	25C62KFC	2	Flat head cap screw, 1/4"-20 x .625"
3	24050	4	Button head cap screw, 1/4"-20 x .625"
4	481C-6	1	Retainer plate, door bearings
5	7340BD	2	Nut, 1-1/8" socket, mainshaft & countershaft
6	6304	2	Bearing, radial ball, 52mm
7	26735	2	Dowel, 3/16" x .500"
8	36805-06F	1	Gasket, side cover
9	73497	8	Socket head cap screw, stainless, 5/16"-18 x 1.500"
10	6100	8	Washer, stainless, .341" x .560" x .058"
11	DD7-10702G	1	Bearing door, DD7, polished
	DD7-10703G	1	Bearing door, DD7, hog black
12	35654-67	1	Gasket, bearing door
13	16583-67	2	Hollow dowel, 10mm x .375"
14	F1409	1	Magnet, .265" x .750" x .250"
15	25C75KCS	1	Socket head cap screw, 1/4"-20 x .750"
16	133-56R-GAS	1	Gasket, speed sensor, .060" thick
17	35223-67A	1	Fork rod, mainshaft, 7.225"
18	35222-67A	1	Fork rod, countershaft, 4.825"
19	N/A	1	DD7 gearset w/ shift system
20	25X52X07ADL	1	Seal, inner primary, 25 x 52 x 7mm
21	P205PP-H	1	Bearing, inner primary, 25 x 52 x 15mm
22	34917-06F	1	Gasket, top cover, Twin Cam
	25700453	1	Gasket, top cover, M8

GEARSET EXPLODED VIEW

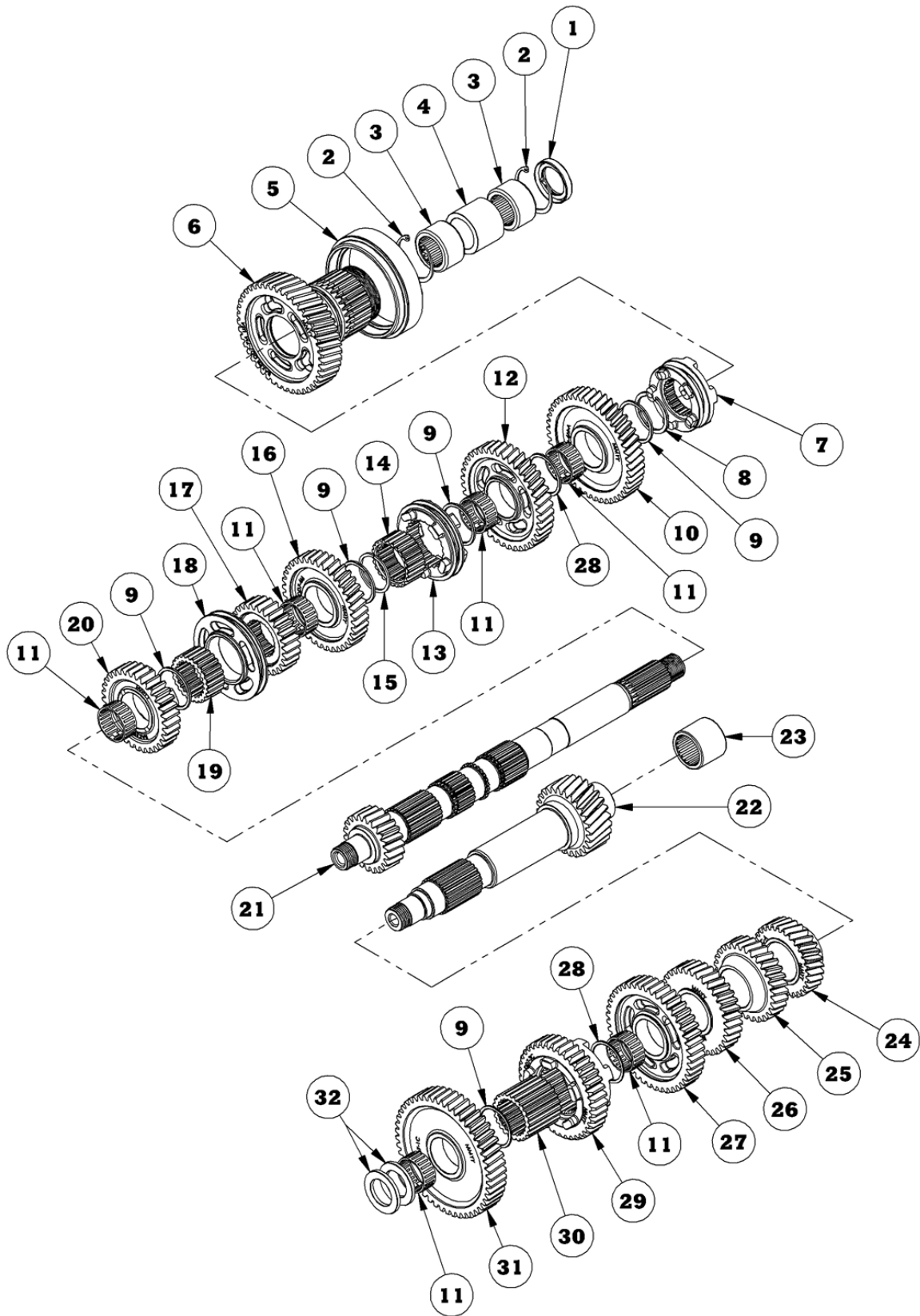

FIGURE 4 | EXPLODED VIEW, GEARSET

GEARSET PARTS LIST

ITEM	P/N	QTY	DESCRIPTION
1	12077	1	Seal, main drive gear, output
2	68057	2	Retaining ring, internal
3	8042	2	Bearing, drawn cup needle
4	11599	1	Spacer, main drive gear
5	N/A	1	Tapered roller bearing assembly
6	DD7-7M-TB	1	7 th gear, mainshaft, 44T, helical
7	DD6-4C5-1	1	Dog clutch, 6 th - 7 th gear, mainshaft
8	11067	1	Retaining ring, external, eaton style, 30mm
9	6003B	5	Thrust washer, 1.185" x 1.380" x .071"
10	DD7-6MG	1	6 th gear, mainshaft, 46T, helical
11	8876A	6	Bearing, split cage needle, 26 x 30 x 13mm
12	DD7-5ME	1	5 th gear, mainshaft, 40T, helical
13	DD7-DC45D	1	Dog clutch, 4 th - 5 th gear, mainshaft
14	DD7-SP45D	1	Splined spacer, 4 th - 5 th gear, mainshaft
15	11082	2	Segment ring, 1.102" x 1.280" x .056"
16	DD7-4MD	1	4 th gear, mainshaft, 37T, helical
17	DD7-2MC	1	2 nd gear, mainshaft, 22T, spur
18	DD7-DC3D	1	Dog clutch, 3 rd gear, mainshaft
19	DD7-SP23C	1	Splined spacer, 2 nd - 3 rd gear, mainshaft
20	DD7-3ME	1	3 rd gear, mainshaft, 33T, spur
21	DD7-MSE	1	Mainshaft & 1 st gear, 22T, helical
22	DD7-CSF	1	Countershaft & 7 th gear, 26T, helical
23	8963	1	Bearing, drawn cup needle, 30 x 37 x 21mm
24	DD7-6CE	1	6 th gear, countershaft, 30T, helical
25	DD7-5CC	1	5 th gear, countershaft, 30T, helical
26	DD7-4CB	1	4 th gear, countershaft, 34T, helical
27	DD7-2CF	1	2 nd gear, countershaft, 35T, spur
28	6003B-065	2	Thrust washer, 1.185" x 1.380" x .065"
29	DD7-3CF	1	3 rd gear, countershaft, 39T, spur
30	DD7-SP12F	1	Splined spacer, 1 st - 2 nd gear, countershaft
31	DD7-1CF	1	1 st gear, countershaft, 49T, helical
32	TWD1423	2	Thrust washer, .883" x 1.420" x .125"

TAPERED BEARING EXPLODED VIEW AND PARTS LIST

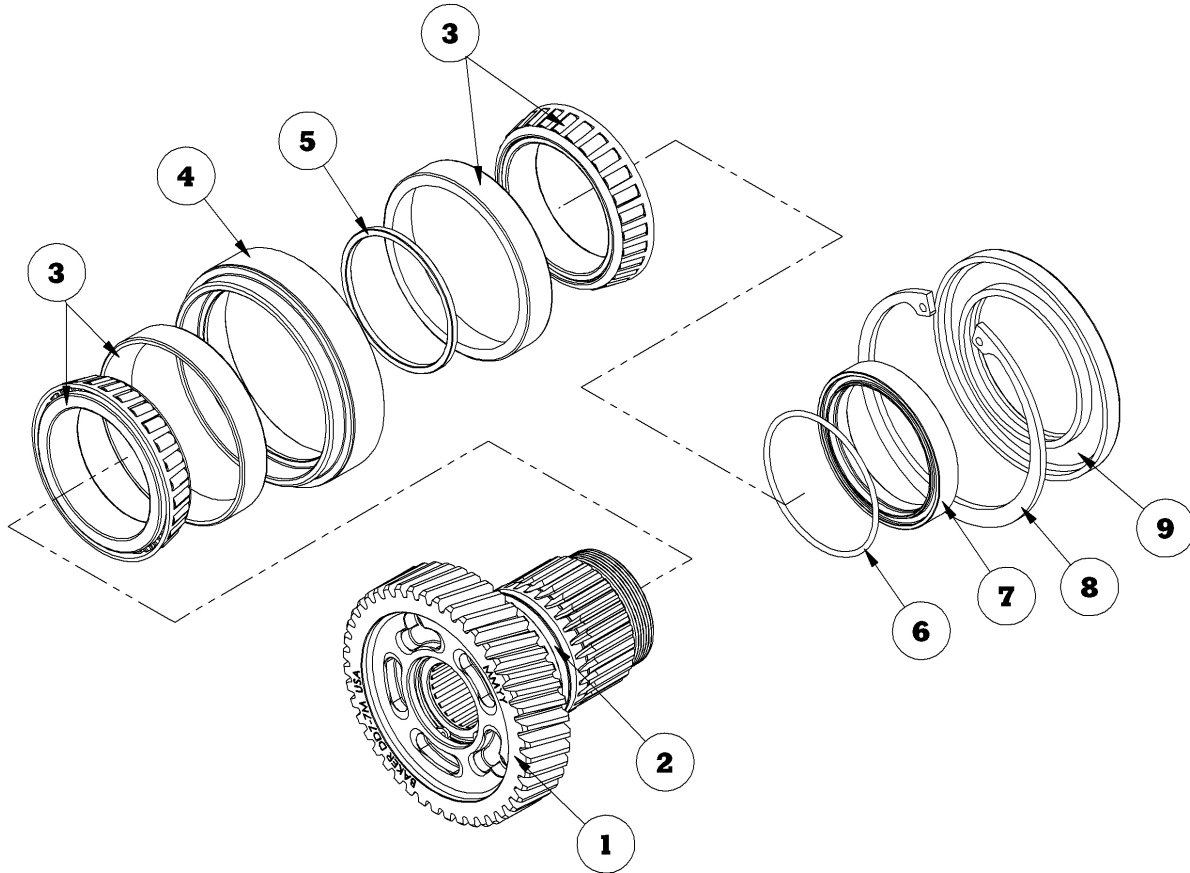

FIGURE 5 | EXPLODED VIEW, TAPERED ROLLER BEARING

ITEM	P/N	QTY	DESCRIPTION
1	DD7-7M-TBA	1	7 th gear, mainshaft, 32T, helical
2	OR568133	1	O-ring, Buna #133
3	HR32910J	2	Bearing, tapered roller, 50 x 72 x 15mm
4	11610-GB	1	Adapter, tapered roller bearings
5	11615-GB	1	Spacer, tapered roller bearings, .104", green**
	11620-GB	1	Spacer, tapered roller bearings, .106", blue*
	11625-GB	1	Spacer, tapered roller bearings, .108", red**
6	OR568M52	1	O-ring, pulley / sprocket spacer, 52mm
7	33334-GB	1	Spacer, pulley / sprocket
8	VHO-334STPA	1	Retaining ring, beveled internal, 85mm
9	12074-67	1	Seal, main drive gear, 2.380" x 3.375" x .285"

* .106" spacer (blue) is pre-installed on the main drive gear

** .104" (green) and .108" (red) spacers are included separately in your kit

BEFORE INSTALLING YOUR DD7

BEFORE YOU BEGIN

The transmission is a component in the powertrain of your motorcycle. As such, its function is highly dependent on other components in the powertrain to perform as designed. If the clutch, clutch actuator, primary, or shift linkage is worn, tired, or compromised in any way, the transmission will not perform as designed. The process of installing the DD7 is the perfect time to assess and freshen up these components to ensure the transmission gives you years of trouble-free service.

TORQUE SPECIFICATIONS

THREAD	APPLICATION	TORQUE VALUE	THREADLOCKER
1/4"-20	Side cover, top cover, derby cover, outer primary, VSS, pulley locking plate	132 – 156 in-lb	Blue recommended
5/16"-18	Bearing door, inner primary	22 – 25 ft-lb	Blue recommended
5/16"-24	Shift arm pinch bolt	18 – 22 ft-lb	Blue recommended
9/16"-12	Comp sprocket bolt	See Factory Service Manual	Red required
3/4"-18	Clutch nut	70 – 80 ft-lb	Red required
1-3/4"-20	Pulley/sprocket nut	100 ft-lb, loosen 1 full turn, then 35 ft-lb + 35° – 40°	Red required
9/16"-18	Neutral switch	120 – 180 in-lb	None
3/4"-16	Transmission dipstick	25 – 75 in-lb	None
1/2"-20	Transmission drain plug	14 – 21 ft-lb	None
1/2"-20	Primary drain plug	14 – 21 ft-lb	None

STOCK COMPONENT REMOVAL

Refer to your Factory Service Manual for detailed instructions on how to remove your stock gearset, main drive gear, shifter pawl, and speed sensor from the transmission case. Softails, Dynas, and Touring models are all different configurations and require different methods to accomplish the removal. Ensure that you have the correct Factory Service Manual for your year and model of motorcycle.



THE COUNTERSHAFT CUP BEARING MUST BE REMOVED FROM THE TRANSMISSION CASE AT THIS TIME. USE BAKER TOOLE-07 OR EQUIVALENT.

A REPLACEMENT IS PROVIDED IN YOUR KIT, BUT IT WILL BE INSTALLED AFTER THE TAPERED BEARING ADAPTER.

BERT TIPS:

Apply heat to the comp sprocket bolt head prior to removal. Failure to do so could result in mangled sprocket shaft threads and halt the installation of your DD7.

Remove the dipstick prior to removing the gearset from the transmission case. Failure to do so will result in a broken dipstick and a trip to the nearest H-D dealer.

BEFORE INSTALLING YOUR DD7

TRANSMISSION CASE PREPARATION

Surgically clean the left side of the transmission case in preparation for installing the new DD7 main drive gear and gearset. This surgical cleansing includes the main drive gear and countershaft bearing boss areas, the three inner primary mount bosses, and the shifter pawl boss. See figure 7.

The bearing boss areas must be clean to ensure that no dirt or debris scores the bearing bores during the removal of old bearings and installation of new ones. The three inner primary mount bosses need to be clean so that the tool plate registers flat on the left side transmission case.



FIGURE 7 | SURGICALLY CLEAN THE LEFT SIDE OF THE TRANSMISSION CASE IN THE AREAS INDICATED ABOVE

CAUTIONARY NOTE

There are special tools available from other manufacturers that remove and install the countershaft cup bearing, but they all have one fundamental error – they push on the inside of the cup (from right to left in the motorcycle) for removal and installation. THIS IS WRONG! Cup bearings require that the installation force be applied to the outside of the cup (from left to right). BAKER TOOLE-07 (sold separately) applies removal and installation forces in the proper direction.



VISIT THE BAKER DRIVETRAIN YOUTUBE CHANNEL AND WATCH [CLASS #4](#). IN THIS VIDEO, WE SHOW YOU HOW TO INSTALL THE TAPERED BEARING ADAPTER AND MAIN DRIVE GEAR. WATCHING THE VIDEO AHEAD OF TIME WILL GIVE YOU THE TIPS, TRICKS, AND KNOWLEDGE REQUIRED FOR PROPER INSTALLATION.

INSTALLING THE TAPERED BEARING ADAPTER

TAPERED BEARING ADAPTER INSTALLATION

1. Apply a thin coating of oil to the outer diameter of the tapered bearing adapter. Do the same to the main drive gear bearing bore in the transmission case.
2. Use the aluminum cup provided in your kit in combination with the main drive gear installation tool (BAKER TOOLA-07 or H-D equivalent 35316C) to install the tapered bearing adapter. Refer to the section on installing the main drive gear bearing in your Factory Service Manual. The tool will be set up in a similar manner, but with a few key differences. The tapered bearing adapter will take the place of the traditional main drive gear bearing, and the included aluminum cup will take the place of the bearing driver. See figures 8 and 9 for the proper tool setup.

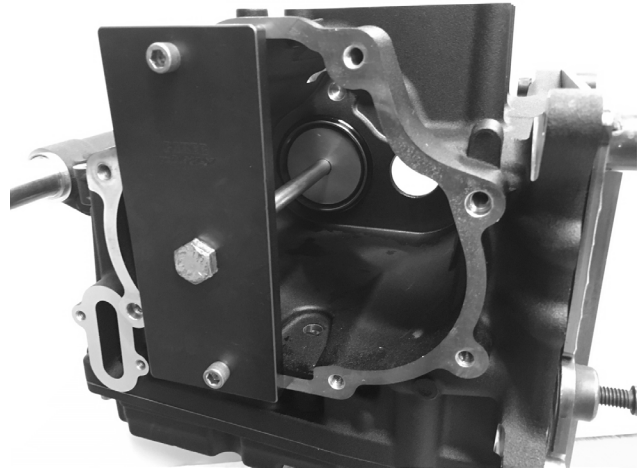

FIGURE 8 | TAPERED BEARING ADAPTER TOOL SETUP, RIGHT SIDE VIEW



FIGURE 9 | TAPERED BEARING ADAPTER TOOL SETUP, LEFT SIDE VIEW

3. Assemble the tool with the stepped down portion of the tapered bearing adapter facing toward the inside of the case; see figure 10. **Make sure that the adapter is square to the bearing bore** and snug the tool nut. If the adapter is not square to the bore, loosen the nut and realign the adapter.

Leave the nut snug. Do not press the adapter into the case.



FIGURE 10 | TAPERED BEARING ADAPTER ORIENTATION IN CASE, TOP VIEW

INSTALLING THE TAPERED BEARING ADAPTER

4. The tapered bearing adapter has a tighter press fit into the transmission case than the stock bearing. To ensure successful installation of the tapered bearing adapter and longevity of the installation tool, you must heat the transmission case as shown in figure 11. Use a MAP/propane torch or a heat gun as shown in figure 12.

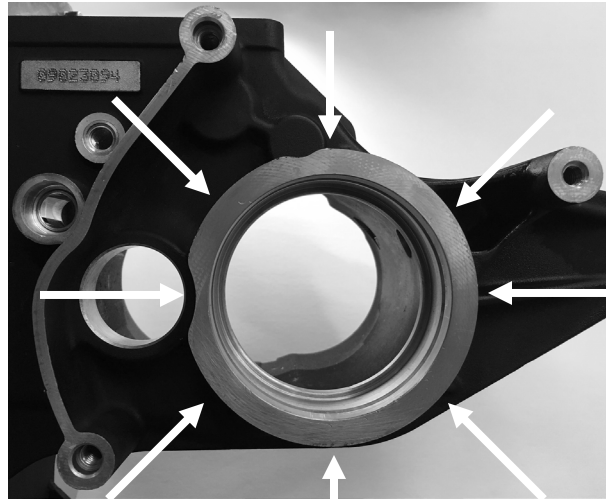

FIGURE 11 | APPLY HEAT AROUND THE MAIN DRIVE GEAR BEARING BOSS AREA

5. Apply heat evenly around the boss of the main drive gear bearing bore from the outside of the case as shown in figure 11. DO NOT heat the boss from the inside of the case and keep heat away from the tapered bearing adapter that is staged and ready for installation. The bearing bore boss should be heated to at least 200°F. BAKER recommends using an infrared thermometer to verify that the case is adequately heated; see figure 13.



FIGURE 12 | USE MAP/PROPANE GAS OR A HEAT GUN TO HEAT THE CASE

BERT TIP:

You may see some discoloration where the case is heated. Restore color by rubbing a little bit of WD-40® or another thin oil into the powdercoat.



FIGURE 13 | USE AN INFRARED THERMOMETER TO VERIFY THAT THE CASE IS HEATED TO AT LEAST 200° F

INSTALLING THE TAPERED BEARING ADAPTER

- Immediately after the case is heated, tighten the tool nut to draw the tapered bearing adapter into the case. This operation must be done quickly with no interruptions while the case is hot. If the support plate on the other side of the case starts to bend, stop, loosen the nut slightly, and reheat the case. The aluminum cup should be about flush with the bearing boss when the tapered bearing adapter is fully seated; see figure 14.

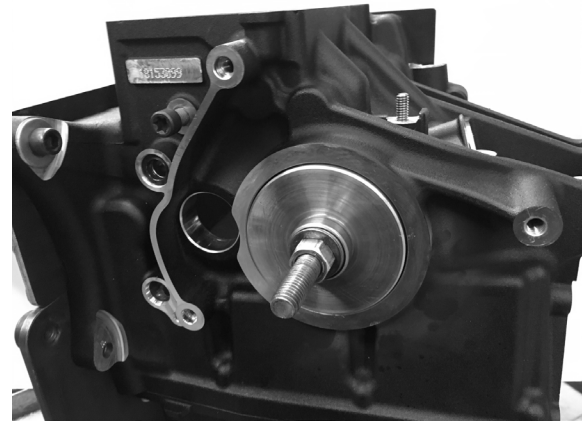

FIGURE 14 | TAPERED BEARING ADAPTER FULLY SEATED IN CASE

BERT TIP:

Do not over tighten the nut after the tapered bearing adapter is bottomed out. Doing so may damage the tool or the transmission case.

- Remove the installation tool. You will know the tapered bearing adapter is seated into the bore when the beveled retaining ring groove is fully visible; see figure 15.



FIGURE 15 | TAPERED BEARING ADAPTER VISUAL INSPECTION

- Install the beveled retaining ring (VHO-334STPA) with the bevel facing outward. Make sure that the retaining ring fully seats into the groove; see figure 16.

**BEVEL ON RETAINING RING
MUST FACE OUTWARD**

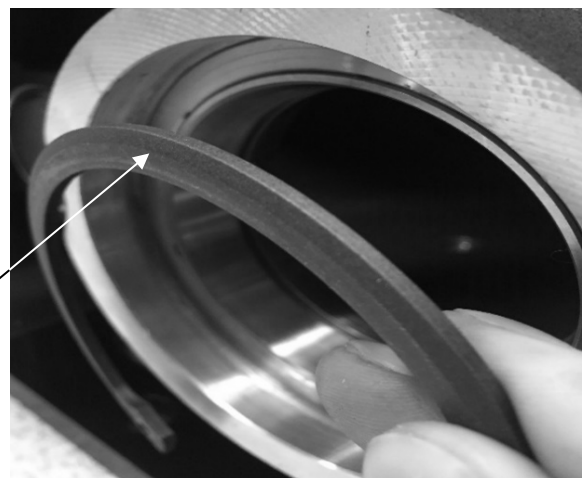

FIGURE 16 | BEVELED RETAINING RING WITH BEVEL FACING OUTWARD

INSTALLING THE C/S BEARING & MAIN DRIVE GEAR

COUNTERSHAFT BEARING INSTALLATION

1. It is now time to install the new countershaft bearing that was provided in your kit. It is important that this step be done **AFTER** installing the tapered bearing adapter. This is to avoid cooking your new countershaft bearing while heating the case in that step.
2. Wipe out the countershaft bearing bore with a clean rag. Apply a thin coating of oil to both the bearing bore and the outer diameter of the countershaft bearing.
3. Use a countershaft bearing tool (BAKER TOOLE-07 or equivalent) to press the bearing into the transmission case. You want to press on the outside of the 'cup', just as you did during removal. See the appropriate tool instructions and your Factory Service Manual for details.

MAIN DRIVE GEAR INSTALLATION

1. Before installing the main drive gear, apply a thin coating of transmission oil to the tapered bearing races and the main drive gear O-ring; see figure 17. A thicker oil could give you a false reading when checking endplay.



FIGURE 17 | LIGHTLY OIL BEARING RACES BEFORE INSTALLING THE MAIN DRIVE GEAR

2. Each kit comes with three spacers for setting up end play in the tapered roller bearings: .104" (green), .106" (blue) and .108" (red) thick. The most commonly used spacer (.106", blue) is pre-installed on the main drive gear. The .104" and .108" spacers are included for cases where bearing end play is outside of the acceptable range with the pre-installed .106" spacer; see figure 18.

Apply a thin coating of transmission oil to the main drive gear O-ring each time you change the spacer.



FIGURE 18 | MAIN DRIVE GEAR WITH PRE-INSTALLED SPACER AND ONE OF THE EXTRAS; LUBE O-RING

INSTALLING THE MAIN DRIVE GEAR

- Follow the Factory Service Manual to install the main drive gear using BAKER TOOLA-07 or H-D equivalent 35316C. If the H-D equivalent tool is used, you will need to use pulley spacer 33334-GB from your kit for extra spacing while pressing the tapered bearings together.

If you need to use the pulley spacer (33334-GB), temporarily remove the O-ring. Remember to re-install it after the end play is set.

- Gently slide the assembled main drive gear through the case. Take the loose tapered roller bearing (HR32910J) and slide it over the main drive gear, letter side facing out. Slide the pulley spacer onto the gear if needed (O-ring groove facing bearing), followed by the remaining press tools; see figure 19.

BERT TIP:

Apply pressure to the main drive gear during this step by reaching your left hand through the top of the transmission case. Failure to do so (i.e. allowing the gear to flop around) will damage the bearing races.

- With the tooling installed, snug the assembly by hand while making sure the installation tool cup is properly aligned and not skewed to the side of the tapered bearing. Hold the bolt on the inside of the case using the proper socket and ratchet. Tighten the main drive gear tooling on the primary side of the bike until it is fully seated and tight. Refer to the main drive gear tool instructions and figure 20.



FIGURE 19 | IF USING H-D TOOLING, THE PULLEY SPACER IS NEEDED TO EXTEND THE LENGTH OF THE INSTALLATION CUP



FIGURE 20 | INSTALLING THE MAIN DRIVE GEAR

INSTALLING THE MAIN DRIVE GEAR

6. Do not remove the installation tool yet; leave everything tight. Measure the amount of endplay in the main drive gear assembly using a dial indicator with .0005" increments as shown in figure 21. **Total axial end play (pulling / pushing on the gear) must be between .0005" and .002"**. It is extremely important that your bearing end play is within this range, as anything too tight or too loose may lead to transmission failure.

Measuring end play is tricky. The end play measurement can easily be skewed if radial or rotational forces are applied, so try to keep all movement in the axial direction (parallel to the mainshaft). A correctly set up tapered roller bearing should be very tight. When you think your measurement is between .0005" – .002", try spinning the main drive gear. If it spins freely with no drag and no excessive noise, setup is complete and you may proceed to the next step.



FIGURE 21 | CHECKING AXIAL END PLAY IN THE MAIN DRIVE GEAR TAPERED ROLLER BEARING

Watch [Class #4](#) on the *BAKER Drivetrain* YouTube channel for a video tutorial on setting up end play in the main drive gear bearing.



IF YOUR SETUP IS TOO TIGHT (UNDER .0005"), REMOVE THE MAIN DRIVE GEAR FROM THE CASE USING THE PROPER TOOLING. REMOVE THE O-RING FROM THE 'SNOUT' OF THE MAIN DRIVE GEAR FOLLOWED BY THE .106" (BLUE) SPACER. INSTALL THE .108" (RED) SPACER, REPLACE THE O-RING, AND GO BACK TO STEP 4.



IF YOUR SETUP IS TOO LOOSE (OVER .002"), REMOVE THE MAIN DRIVE GEAR FROM THE CASE USING THE PROPER TOOLING. REMOVE THE O-RING FROM THE 'SNOUT' OF THE MAIN DRIVE GEAR FOLLOWED BY THE .106" (BLUE) SPACER. INSTALL THE .104" (GREEN) SPACER, REPLACE THE O-RING, AND GO BACK TO STEP 4.

7. Remove the tooling used to install the main drive gear along with pulley spacer if you had to use it. If necessary, reinstall the O-ring (OR568M52) that you removed from the pulley spacer in step 3.

INSTALLING THE MAIN DRIVE GEAR

- Put some transmission fluid on the outer diameter and O-ring of the pulley spacer. Install it onto the main drive gear with the O-ring facing inward (toward the bearing); see figure 22.



FIGURE 22 | INSTALLING THE PULLEY SPACER AND THE MAIN DRIVE GEAR SEAL

- Put some transmission fluid on the lip of the main drive gear seal and install it. Make sure the seal is flush with the transmission case all the way around the bearing boss; see figure 23.

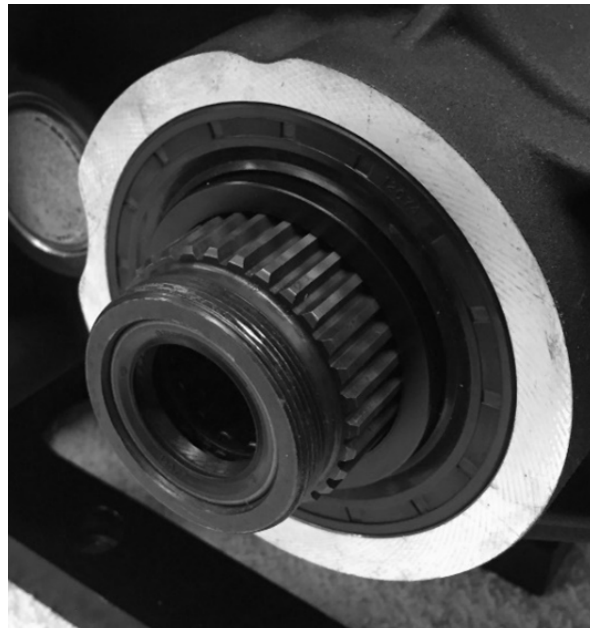

FIGURE 23 | MAIN DRIVE GEAR SEAL INSTALLED FLUSH WITH CASE

INSTALLING THE GEARSET

SHIFTER PAWL INSTALLATION

1. If you removed the stock centering pin to clean the case, reinstall it with red threadlocker. Install the DD7 shifter pawl along with the new seal, washer, and 7/16" retaining ring just like a stock shifter pawl is installed. Lift up on the shifter pawl arm and place it on top of the transmission top cover gasket face; see figure 24.



FIGURE 24 | LIFT THE PAWL ARM ONTO THE GASKET SURFACE UNTIL THE GEARSET IS INSTALLED AND THE BOLTS ARE TORQUED

CASE CLEARANCE CHECK

2. The time has come to stuff the gearset (figure 25) into the transmission case. Before that is done, take time to ensure that your DD7 fits the case with no clearance issues and that no debris or tarantulas have found their way into the case. Check that the two bearing door dowels came out of the case with old bearing door.

Generously apply transmission lube to the last 6" of the mainshaft, end of the countershaft, countershaft bearing, tapered roller bearings, and the bearings/seal in the main drive gear. Do not remove the black rubber cap from the end of the mainshaft. Its function is to protect the seal in the main drive gear as the gearset is installed.



FIGURE 25 | DD7 GEARSET READY FOR INSTALLATION INTO THE CASE

INSTALLING THE GEARSET

- The BAKER DD7 is designed to fit in stock H-D® transmission cases without modification to the case or the 7-speed components. Since most aftermarket cases are styled after the H-D® equivalent, the DD7 will fit into aftermarket cases as well. This applies in most situations, but there are exceptions. The internal walls of the cases occasionally 'float around' in H-D® and aftermarket castings. This is not an indication of poor quality; it is inherent in the casting process. Be sure to check for any potential interference between the case and gearset before final installation.

A pre-check can be done by first inserting the DD7 gearset into the case. Hold the door firmly against the case and slowly spin the mainshaft. Remove the gearset and check for any indication of gear-to-case contact. In the situation that you see evidence of interference (as shown in Figure 27), you will need to make modifications.

Carefully mask off the new components you just installed or place a towel on the inside of the case to block any debris from getting to the new countershaft bearing, main drive gear bearings and shifter pawl area.

Any necessary case modification can be done with a die-grinder or file. Remove just enough material from the side of the case (contact area) until the gearset no longer interferes with the internal wall.

Carefully remove the towel or masking and thoroughly clean the inside of the case before gearset installation.



FIGURE 26 | INSIDE OF THE STOCK CASE; NO GEAR TO CASE INTERFERENCE SEEN ON THE INSIDE.

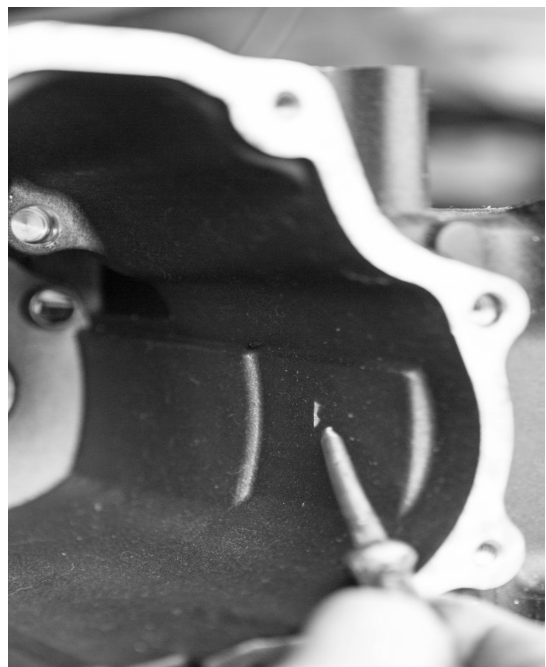

FIGURE 27 | DD7 2ND COUNTERSHAFT GEAR CONTACTING THE INNER WALL OF THE TRANSMISSION CASE

INSTALLING THE GEARSET

GEARSET INSTALLATION

- Place the new bearing door gasket onto the dowels of the DD7 bearing door. Carefully install the gearset into the transmission case. It is helpful to have a second set of hands on the left side of the motorcycle to grab onto the mainshaft as it passes through the main drive gear. The person on the left side can help the process along by gently rotating the main drive gear back and forth; this helps the 5th gear on the countershaft find home with the main drive gear.

It is rare, but sometimes the fork rods need to be jostled to find home on the left side of the transmission case.

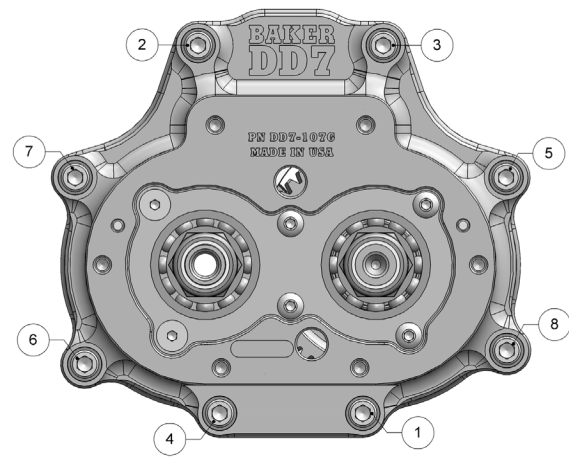

FIGURE 28 | TORQUE SEQUENCE FOR DD7 BEARING DOOR BOLTS

- Install the eight stainless steel cap screws and washers (rounded side down) onto the bearing door using blue threadlocker. Be sure to replace the exhaust bracket beneath the bottom inner bolts. Torque to 22 – 25 ft-lb using the torque sequence in figure 28. You may remove the zip tie from the shifter pawl and the black rubber cap from the mainshaft at this time.
- Locate the speed sensor that was removed from the transmission case during stock component removal. Remove the O-ring from the speed sensor, install the provided spacer (133-56R-GAS), and re-install the O-ring. The speed sensor with spacer can now be placed back into the transmission case. Torque the bolt to 125 – 135 in-lb with blue
- With the new side cover gasket in place, re-install the side cover and torque the bolts to 125 – 135 in-lb with blue threadlocker. Go to the other side of the motorcycle and re-install the drive pulley or sprocket onto the main drive gear. Use BAKER TOOLD-07 or H-D equivalent to torque the pulley / sprocket nut to 35 ft-lb + 35° – 45° with red threadlocker. Refer to your Factory Service Manual for details.

TRANSMISSION FLUID

- Re-install the transmission drain plug and torque it to 14 – 21 ft-lb. Re-install the transmission dipstick and torque it to 25 – 75 in-lb.
- Put 28-32 oz. transmission fluid (75-85W140 synthetic gear oil) into the transmission by pouring it through the top cover cavity onto the main drive gear and shifter pawl. Make sure to coat as much of the gearset components as possible with the fluid.

FINISH LINE

FINAL STEPS

1. Re-install the top cover with the new gasket provided. Button up the primary, exhaust, shift linkage, and floorboards/footpegs per your Factory Service Manual. Make sure to re-install the primary drain plug and fill the primary with fluid.
2. You have successfully completed the installation of your new transmission. Be observant of basic transmission function and overall vehicle operation during the first 20 miles. Check for leaks after your first ride. Provided there are no issues, ride on and enjoy your new BAKER DD7!

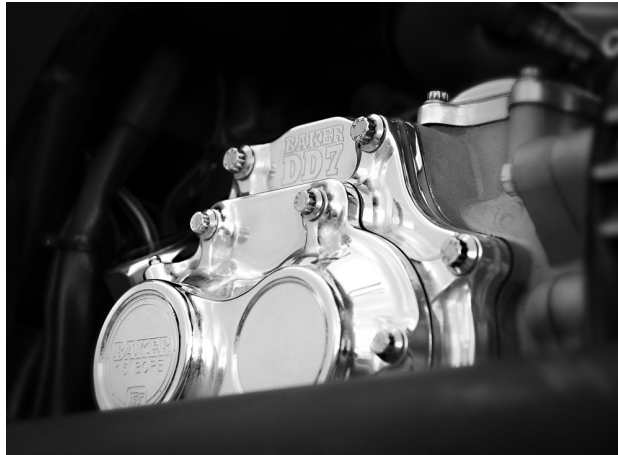

FIGURE 29 | INSTALLED DD7 SHOWN WITH
OPTIONAL HYDRAULIC SIDE COVER;
PN DD7-106C-KIT

SPEEDOMETER, GEAR INDICATOR, & CRUISE CONTROL

The DD7 has different gear ratios than the stock transmission (except 7th gear is the same as stock 6th gear, 1:1). This changes the input to the ECM. The 6th gear indicator light will come on when the DD7 is shifted into 7th gear. Cruise control function is affected, may only operate in 5th-7th gear. To correct the gear indicator in all gears and enable cruise control function in 3rd, 4th, 5th, 6th, and 7th an ECM re-flash is required.

ECM RE-FLASH VALUES

DD7 Gearset | Dynojet Power Vision

2nd – 0.22296
3rd – 0.30560
4th – 0.38679
5th – 0.49366
6th – 0.53426
7th – 1.00000

DD7 Gearset | TTS Master Tune

2nd – 0.36260
3rd – 0.48485
4th – 0.64305
5th – 0.78788
6th – 0.90606
7th – 1.00000

TERMS & CONDITIONS

ORDERS

Orders can be pre-paid using VISA, MasterCard, American Express, and Discover or via wire transfer (\$30 wire transfer fee applies). All orders not pre-paid will be sent C.O.D. certified check or money order only unless pre-approved for company check acceptance. Any orders from outside the USA must be pre-paid in US funds via wire transfer (\$30 transfer fee applies). Prices shown are F.O.B. Haslett, MI. BAKER™ ships via UPS Ground or USPS Parcel Post for all orders. UPS air shipment or USPS Priority/ Express services are available upon request. Customer is responsible for all shipping charges unless otherwise arranged at the time of sale.

CUSTOMER SUPPORT

For any installation or service questions, please contact our BAKER technical department: 1-517-339-3835.

LIMITED WARRANTY

NOTE: Warranty card must be returned within 45 days of purchase for your warranty to be valid.

BAKER™ transmission assemblies and transmission builder 's kits, are guaranteed to the original purchaser to be free of manufacturing defects in materials and workmanship for a period of 5 years from the date of purchase or up to 50,000 miles, whichever occurs first. All other BAKER products are guaranteed to the original purchaser to be free of manufacturing defects in materials and workmanship for a period of 2 years from the date of purchase or up to 24,000 miles, whichever occurs first, except for the following; Warranty does not cover clutch plate wear, throw out bearing failures or mainshaft breakage due to improper clutch nut installation.

Electrical components carry a 30-day warranty; cosmetic finishes (chrome plating, hard anodizing, powder coating) are covered for 60 days. Certain promotional products may carry a shorter warranty as specified at the time of purchase. If the product is found by BAKER to be defective, such products will, at the option of BAKER, be replaced or repaired at cost to BAKER .

In the event warranty service is required, the original purchaser must call or write BAKER immediately with a description of the problem. If it is deemed necessary for BAKER to make an evaluation to determine whether the transmission assembly or transmission kit or accessory is defective, the entire transmission assembly, whether originally purchased as an assembly or kit, must be properly packaged and returned prepaid to BAKER with a copy of the original purchase invoice. If after evaluation by BAKER a defect in materials and/or workmanship is found, BAKER will, at their option, repair or replace the defective part of the assembly.

RETURNS AND EXCHANGES

Any merchandise returned for any reason (exchange, credit or modification) must be accompanied by a Return Goods Authorization (RGA) number or it will be refused. Call BAKER to obtain this number prior to returning goods for any reason. There is a 15% re-stocking fee for all returned items.

BAKER is not liable for any shipping.

ADDITIONAL WARRANTY PROVISIONS

NOTE: Limited warranty does not cover labor or other costs or expenses incidental to the repair and or replacement of BAKER products.

This warranty does not apply if one or more of the following situations is judged by BAKER to be relevant: BAKER OEM transmissions ; (these are subject to the OEM manufacturers warranty only), Improper installation , accident, modification (including but not limited to use of unauthorized parts, transmission oils or lubricants), racing, high performance application, mishandling, misapplication, neglect (including but not limited to improper maintenance), or improper repair.

BAKER shall not be liable for any consequential or incidental damages arising out of or in connection with a BAKER transmission assembly, transmission kit, component or part. Consequential damages shall include without limitation, loss of use, income or profit, or losses sustained as the result of injury (including death) to any person or loss of or damage to property.

BAKER transmissions, transmission kits and accessories are designed exclusively for use in American V-Twin motorcycles. BAKER shall have no warranty or liability obligation if BAKER parts are used in any other application

If it is determined that a BAKER product has been disassembled during the warranty period for any reason, this limited warranty will no longer apply unless you were instructed to do so by a BAKER Drivetrain technician for diagnostic purposes.

TRANSMISSION OIL CHANGE LOG

DATE	ODOMETER	OIL USED	SERVICED BY
	500		
	2,500		
	7,500		
	12,500		
	17,500		
	22,500		
	27,500		
	32,500		
	37,500		
	42,500		
	47,500		
	52,500		
	57,500		
	62,500		
	67,500		
	72,500		
	77,500		
	82,500		
	87,500		
	92,500		

High Torque Bearing Kit Addendum

High Torque Bearing Kit Seal

Installation

Please install the seal with the flat side facing the transmission (showing). If you have any further questions, please give us a call at 517-339-3835.

