

BAKER BILLET KICKER COVER KIT



4-SPEED BILLET KICKER COVER

- P/N:** 478-56MP-K (MECHANICAL BILLET KICKER COVER)
478-56HP-K (HYDRAULIC BILLET KICKER COVER)
478CT02-56-A (CABLE STYLE BILLET KICKER COVER)
479H02-56-A (FF HYDRAULIC BILLET KICKER COVER)
FF stands for Function Formed

BAKER BILLET KICKER COVER KIT OVERVIEW

FEATURES

The new Premium BAKER Billet Kicker Covers is yet another part that we added to the ever growing BAKER product line. These show polished gems are made out of Billet 6061-T6 for added strength and increased part life. Stainless Steel T303 release shaft housing with O-Ring (mechanical version only) keeping that fluid inside the transmission; no more leaking shafts, our renowned strong and smooth BAKER Klassic Kicker Gears, and solid one piece kicker shaft for those guys who just kick the shit out of their bike.

FITMENT

- BAKER 6N4 Transmission
- 4-Speed 1936-1986 FL[®] / FX[®] Models

The BAKER Billet Mechanical Kicker Cover is the most historical; requires the use of a clutch release arm, 1936-1986 Knucklehead / Panhead / Shovelhead Motors.

The BAKER Billet Hydraulic Kicker Cover is designed to work with an 11/16" Bore Diameter Hydraulic Clutch Lever. This is the size of the Factory Clutch Lever, and the most common size of aftermarket Clutch Levers.

The BAKER Billet Cable Type Kicker Cover is designed to work with O.E. type clutch cables from 1990-2006 and includes ball-ramp actuation components.

TOOLS, RESOURCES, REQUIRED PARTS

- Factory Service Manual For Your Motorcycle
- Factory Parts Manual For Your Motorcycle
- Common Hand Tools (allens, sockets, hammer / chisel)
- Torque Wrench (with ft. lbs. and in. lbs.)
- Blue Loctite[®] (242 Removable) or Equivalent
- Red Loctite[®] (271 Permanente) or Equivalent
- Starter Clutch Puller (H-D[®] P/N 95650-42 or equivalent)
- Transmission Fluid: BAKER Recommends: Spectro[™] Heavy Duty Platinum 6 Speed Transmission Oil, P/N R.HDPG6

THESE ADDITIONAL ITEMS ARE NEEDED FOR THE HYDRAULIC KICKER COVERS PN: 478-56HP-K & PN: 479-56P-K

- 10MM Banjo Fittings
- Hydraulic Line
- Hydraulic Fluid: We Recommend H-D[®] DOT 5 Brake Fluid (P/N 99902-77)
- Loctite[®] Thread Sealant (567); available at your local auto parts store
- Hydraulic Master Cylinder with an 11/16" Bore

BAKER BILLET KICKER COVER KIT

TABLE OF CONTENTS:

- 2) Overview
- 3) Table Of Contents
- 4) Included Parts Breakdown FF Hydraulic Cover
- 5) Included Parts Breakdown FF Hydraulic Cover Legend
- 6) Included Parts Breakdown Hydraulic Cover
- 7) Included Parts Breakdown Hydraulic Cover Legend
- 8) Included Parts Breakdown Mechanical Cover
- 9) Included Parts Breakdown Mechanical Cover Legend
- 10) Included Parts Breakdown Cable Style Cover
- 11) Included Parts Breakdown Cable Style Cover Legend
- 12) Cover Preparation
- 13) Cover Preparation Continued, Installation
- 14) Installation Continued
- 15) Installation Continued, Bleeding Hydraulic System
- 16) Bleeding Hydraulic System Continued, Finish Line
- 17) Release Rod for 1936-69 Models
- 18) Terms
- 19) Disclaimer

BAKER BILLET KICKER EXPLODED VIEW

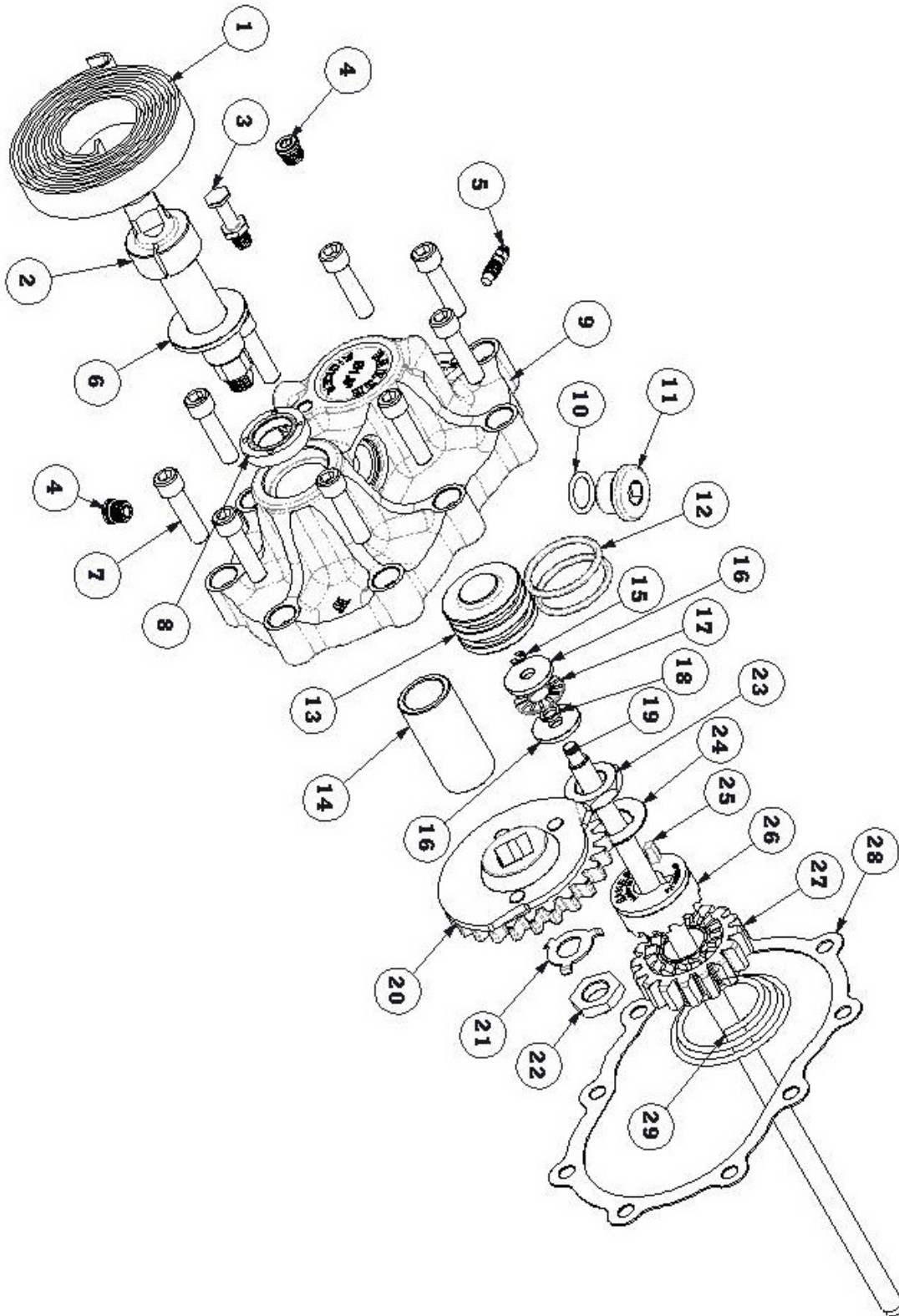

FIGURE 1

BAKER BILLET KICKER EXPLODED VIEW

BILLET FUNCTION FORMED HYDRAULIC COVER KIT INCLUDED PARTS DETAIL FIGURE 1

ITEM	QTY	PN	DESCRIPTION
1	1	291222	Return Spring
2	1	33096-54	Kicker Shaft
3	1	292013	Stud, Return Spring
4	2	51740-001	Zero Leak Drain Plug
5	1	45-9404	Bleeder Screw
6	1	292016	Washer, Kicker Shaft
7	9	73496	5/16-18 X 1 1/4" SHCS
8	1	.750X1.250X.250ADL	Seal, Kicker Shaft
9	1	479HB02-56	FF Hyd. Kicker Cover
10	1	66827	O-Ring, Fill Cap
11	1	13002-56F	Fill Plug
12	2	66855	O-Ring, Hyd. Piston
13	1	124-56LD	Hyd. Piston (1.5" DIA)
14	1	6391K269	Bronze Bushing, 2" Long
15	1	10705-01149	E-Clip, Release Rod
16	2	BD411-56	Thrust Washer
17	1	FNT-1024	Bearing, Heavy Duty Needle
18	1	BD410-56	Spacer, Bearing
19	*1*	7078	1970-E84 Release Rod
20	1	33350-56	Crank Gear
21	1	292014	Lock Tab, Crank Gear
22	1	7073	Nut, Crank Gear
23	1	7071	Nut, Starter Gear
24	1	290225	Lock Washer, Starter Gear
25	1	2213	Key, Starter Gear
26	1	33560-56	Starter Clutch Gear
27	1	33430-56	Starter Gear
28	1	6N4-SIDE	Gasket, Kicker Cover
29	1	290227	Spring, Starter Gear

* = Release Rod For 1970-E84 Models. See Page 17 For 1936-69 Models
Late 1984-Later Must Use Stock Style 3pc Rod

BAKER BILLET KICKER EXPLODED VIEW

INCLUDED PARTS DETAIL HYDRAULIC COVER

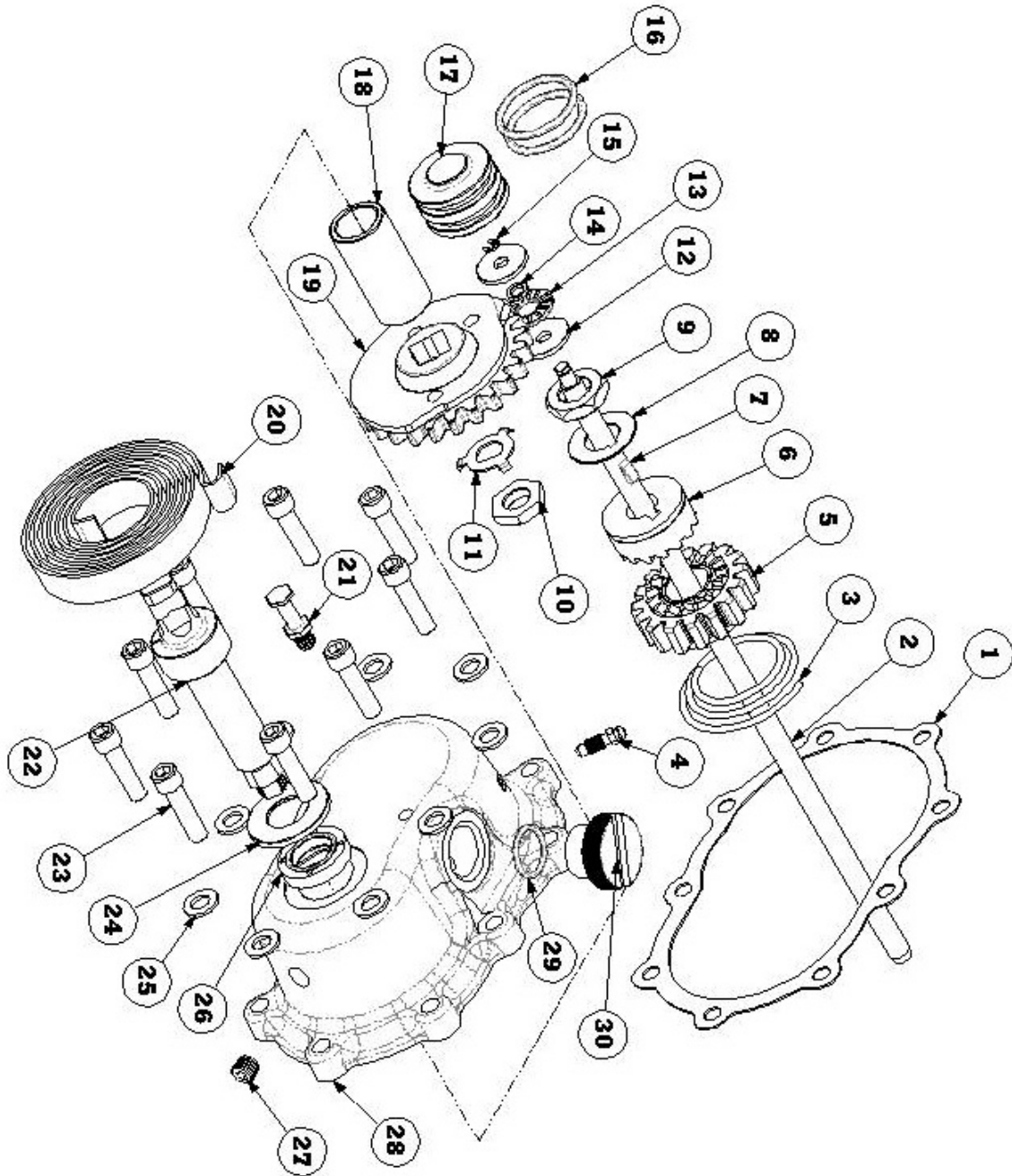

FIGURE 2

BAKER BILLET KICKER COVER EXPLODED VIEW

BILLET HYDRAULIC COVER KIT INCLUDED PARTS DETAIL FIGURE 2

ITEM	QTY	PN	DESCRIPTION
1	1	6N4-SIDE	Gasket, Side Cover
2	*1*	7078	1970-E84 Release Rod
3	1	290227	Spring, Starter Gear
4	1	45-9404	Bleeder Screw
5	1	33430-56	Starter Gear
6	1	33560-56	Starter Clutch
7	1	2213	Key, Starter Clutch
8	1	290225	Lock Washer, Starter Clutch
9	1	7071	Nut, Starter Clutch
10	1	7073	Nut, Crank Gear
11	1	292014	Lock Tab, Crank Gear
12	2	BD411-56	Thrust Washer
13	1	FNT-1024	Bearing, Heavy Duty Needle
14	1	BD410-56	Spacer, Bearing
15	1	10705-01149	E-Clip, Release Rod
16	2	66855	O-Ring, Hyd. Piston
17	1	124-56LD	Hyd. Piston (1.5" DIA)
18	1	639K269	Bronze Bushing
19	1	33350-56	Crank Gear
20	1	291222	Return Spring, Kicker Shaft
21	1	292013	Stud, Return Spring
22	1	33096-54	Shaft, Crank Gear
23	9	73496	5/16-18 x 1 1/4" SHCS
24	1	292016	Washer, Crank Gear Shaft
25	9	6100	Washer
26	1	.750x1.250x.250ADL	Seal, Crank Gear Shaft
27	1	51740-001	Level Plug, 3/8-24 Zero Leak
28	1	478HB02-56	Hydraulic Cover
29	1	2418T141	O-Ring, Buna #116
30	1	292032	Fill Cap

*= Release Rod For 1970-E84 Models. See Page 17 For 1936-69 Models
Late 1984-Later Must Use Stock Style 3pc Rod

BAKER BILLET KICKER COVER EXPLODED VIEW

INCLUDED PARTS DETAIL MECHANICAL COVER

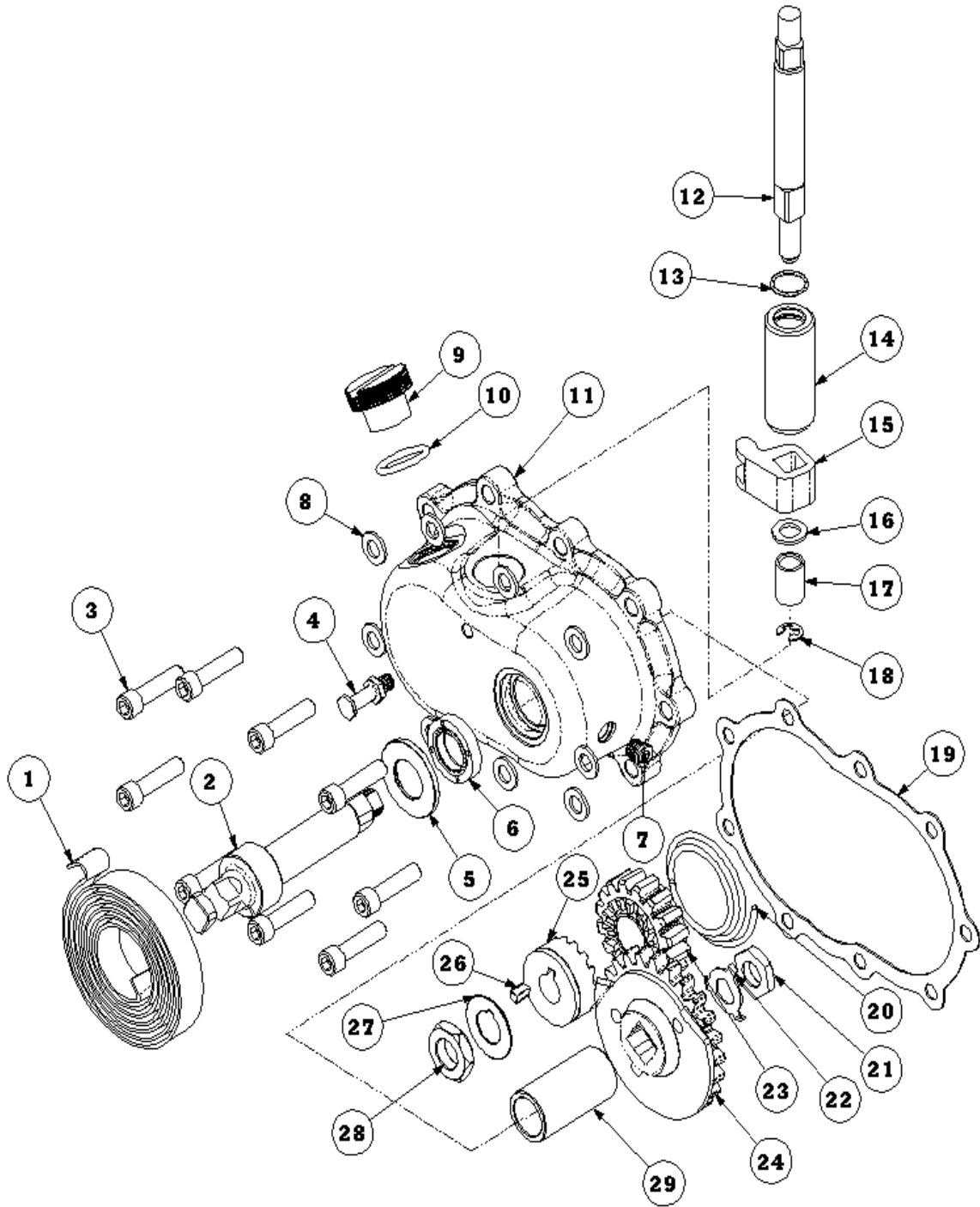

FIGURE 3

BAKER BILLET KICKER EXPLODED VIEW

BILLET MECHANICAL COVER KIT INCLUDED PARTS DETAIL FIGURE 3

ITEM	QTY	PN	DESCRIPTION
1	1	291222	Return Spring, Kicker Shaft
2	1	33096-54	Shaft, Crank Gear
3	9	73496	5/16-18 x 1 1/4" SHCS
4	1	292013	Stud, Return Spring
5	1	292016	Washer, Crank Gear Shaft
6	1	.750x1.250x.250ADL	Seal, Crank Gear Shaft
7	1	51740-001	Level Plug, 3/8-24 Zero Leak
8	9	6100	Washer, 5/16"
9	1	292032	Fill Cap
10	1	2418T141	O-Ring,Buna #116
11	1	478MB02-56	Mechanical Kicker Cover
12	1	37074-38C	Release Shaft
13	1	66808	O-Ring, Release Shaft
14	1	476-56	Release Shaft Housing
15	1	37070-39B	Lever, Release Shaft
16	1	6443HW	Washer, Release Shaft
17	1	6391K183	Bushing, Release Shaft
18	1	68077	E-Clip, Release Shaft
19	1	6N4-SIDE	Gasket, Side Cover
20	1	290227	Spring, Starter Gear
21	1	7073	Nut, Crank Gear
22	1	292014	Washer, Crank Gear
23	1	33430-56	Starter Gear
24	1	33350-56	Crank Gear
25	1	33560-56	Starter Clutch
26	1	2213	Key, Starter Clutch
27	1	290225	Washer, Starter Clutch
28	1	7071	Nut, Starter Clutch
29	1	639K269	Bronze Bushing

BAKER BILLET KICKER COVER EXPLODED VIEW

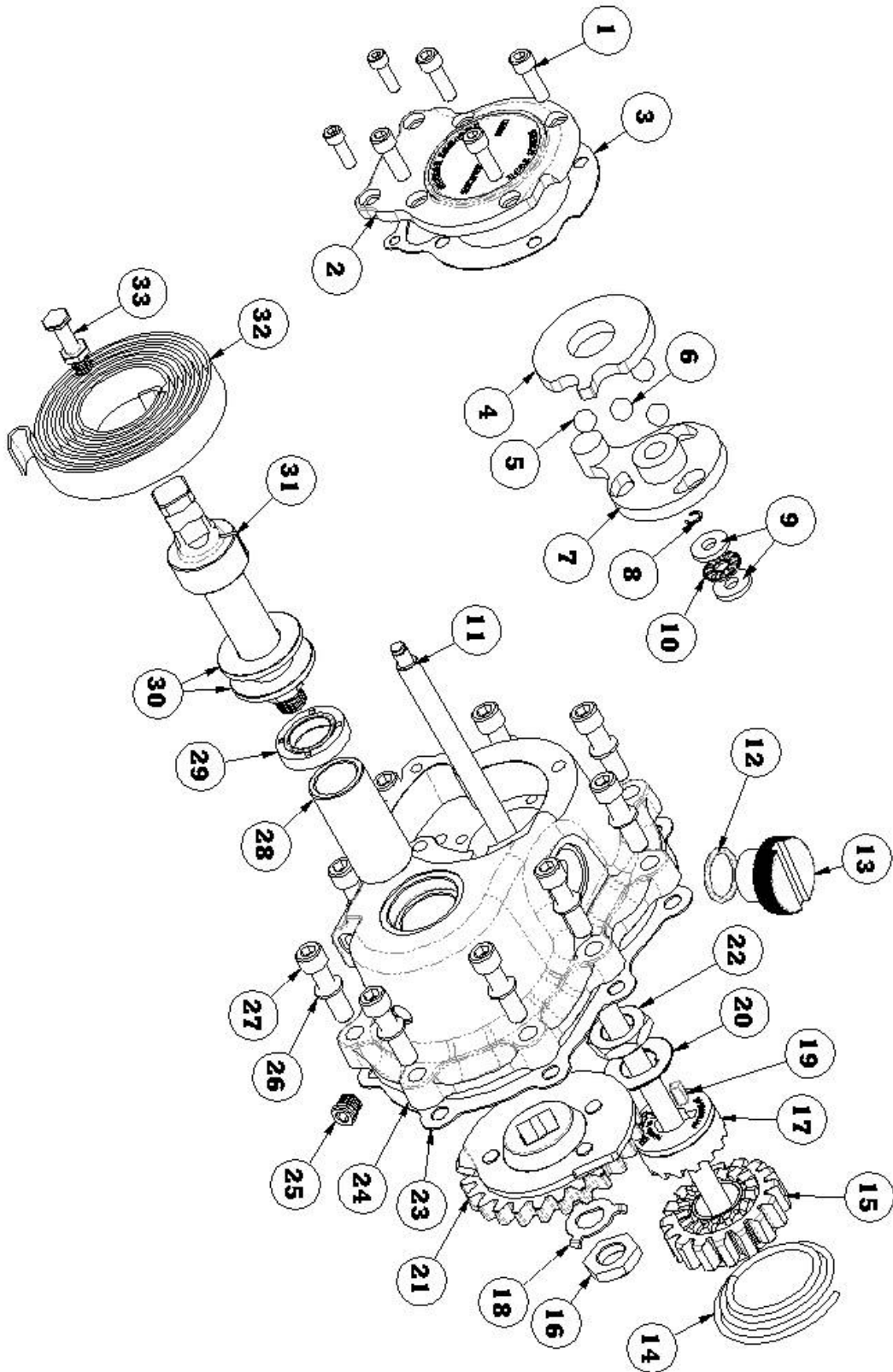

FIGURE 4

BAKER BILLET KICKER COVER KIT

BILLET CABLE STYLE COVER KIT INCLUDED PARTS DETAIL FIGURE 4

ITEM	QTY	PN	DESCRIPTION
1	6	25C50KLHS	1/4-20 x 1/2" Low Head Cap Screw
2	1	58402-F5K	Cover, Ball and Ramp
3	1	587-56	Gasket, Ball and Ramp
4	1	WT3096	Inner Ramp, Actuator
5	3	987687	3/8" Ball Bearing, Actuator Actuator
6	1	3094-DSSC	Ferrule
7	1	WT3196	Outer Ramp, Actuator
8	1	10705-01149	E-Clip, Release Rod
9	2	TWC411	Washer, Actuator Rod
10	1	TC411	Thrust Bearing, Actuator Rod 1970-
11	*1*	7078	E84 Release Rod
12	1	2418T141	O-Ring, Buna #116
13	1	292032	Fill Cap
14	1	290227	Spring, Starter Gear
15	1	33430-56	Starter Gear
16	1	7073	Nut, Crank Gear
17	1	33560-56	Starter Clutch
18	1	292014	Lock Tab, Crank Gear
19	1	2213	Key, Starter Clutch
20	1	290225	Lock Washer, Starter Clutch
21	1	33350-56	Crank Gear
22	1	7071	Nut, Starter Clutch
23	1	6N4-SIDE	Gasket, Kicker Cover
24	1	578CT02-56	Cover, Cable Style
25	1	51740-001	Level Plug, 3/8-24 Zero Leak
26	9	6100	Washer, 5/16" AN
27	9	73496	5/16-18 x 1 1/4" SHCS
28	1	639K269	Bronze Bushing
29	1	.750x1.250x.250ADL	Seal, Crank Gear Shaft
30	2	AS2035	Washer, Crank Gear Shaft
31	1	33096-54	Shaft, Crank Gear
32	1	291222	Return Spring, Kicker Shaft
33	1	292013	Stud, Return Spring

*= Release Rod For 1970-E84 Models. See Page 17 For 1936-69 Models
Late 1984-Later Must Use Stock Style 3pc Rod

BAKER BILLET KICKER COVER KIT

DISSASSEMBLY

- 1) **FOR YOUR SAFETY, DISCONNECT BOTH BATTERY CABLES (FAILURE TO DO SO COULD RESULT IN PERSONAL INJURY).**
- 2) With your bike securely supported on a bike lift or jack, drain the transmission fluid. Refer to your Factory Service Manual for location of your drain plug.
- 3) Depending on the style of exhaust that you have on your motorcycle, the exhaust may need to be removed at this time as well to allow access to the transmission side cover. Remove the stock side cover, as well as the factory clutch actuator rod and set aside.
- 3a) **FOR HYDRAULIC COVERS:** While referencing the Factory Service manual, remove the clutch cable, cable style clutch lever and set aside.
- 4) Remove the derby cover and back off the jam nut for the clutch adjustment.
- 5) Remove the starter clutch, gear and spring following the procedures listed in your Factory Service Manual. Starter Clutch Puller: H-D® P/N 95650-42 or equivalent is necessary for removal.
- 6) Take the time to wipe down the gasket surface of the bearing door and inspect to make sure it is free of residual oil, old gasket material and debris.



THE REMOVAL OF THE OIL DEFLECTOR ON EARLY STYLE 4-SPEED TRANSMISSIONS IS NECESSARY FOR PROPER FITMENT OF THE HYDRAULIC KICKER COVER. IF REMOVING THE STUDS TO USE THE BOLTS SUPPLIED; CHASE THREADS WITH A 5/16-18 TAP USING CAUTION NOT TO DAMAGE THE THREADS IN YOUR CASE.

KICKER COVER PREPERATION

USE CAUTION WHEN ASSEMBLING SO THAT YOU DO NOT DAMAGE THE COVER AND OR ITS COMPONENTS.

- 1) Referring to the exploded view (Figure 1, 2, 3 or 4) apply a little lube in the side cover within the kicker shaft bore and on the shaft seal.
- 2) Install the kicker shaft washer onto the kicker shaft with the inside of the washer chamfer facing toward the threaded end of the shaft. (Figure 5)
- 3) Apply some transmission oil on the kicker shaft and install it through the side cover.

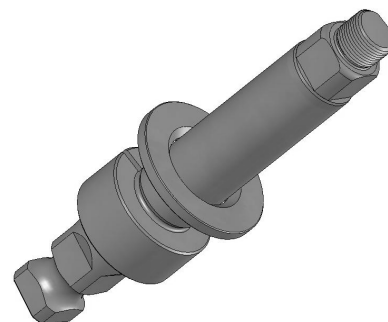

FIGURE 5

NOTE CHAMFER FACING THREADED END



ALIGNMENT OF SHAFT TO CRANK GEAR IS NECESSARY FOR PROPER OPERATION. SEE FIGURE 6. FAILURE TO DO SO COULD RESULT IN DAMAGE TO COVER ASSEMBLY, KICKER GEARS, AND OR PERSONAL INJURY. THE BOTTOM DASHED LINE IS FOR THE CABLE STYLE COVER (478-56CP-K) ALIGNMENT ONLY.

- 4) Install the BAKER crank gear onto the shaft with supplied crank gear washer and crank gear nut using "BLUE" thread lock. Torque to 30 ft lbs.
- 5) Bend over the lock tabs on the crank gear washer to secure the crank gear nut.

(CONTINUED ON NEXT PAGE)

BAKER BILLET KICKER COVER KIT

6a) **FOR HYDRAULIC COVERS:** Remove the hydraulic piston from the side cover. The best way is to use the light touch of an air blow gun in the hydraulic feed port. It should be noted that you should have the side cover back side down on a couple of towels on the work bench when doing this as the piston will shoot out. When you have the piston out, give it a bath of H-D DOT 5 Brake Fluid making sure to fully coat the o-rings in the brake fluid.

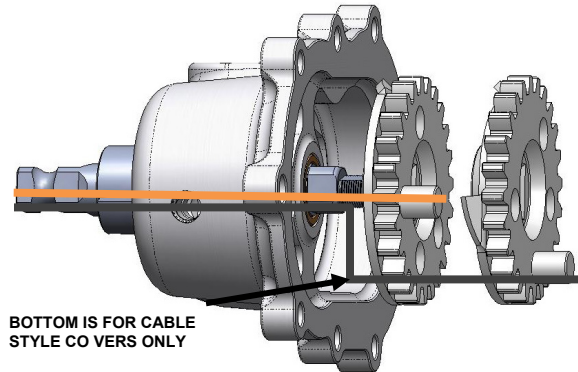

ALIGN GEAR BOSS WITH KEYWAY IN SHAFT **FIGURE 6**

6b) Double check that the inside of the hydraulic bore is free of debris and dirt. Also check the entire inside surface of the side cover to eliminate introducing dirt or packing material into your transmission. With the inside of the part checked and determined to be clean, coat the inside walls of the hydraulic bore with the same H-D DOT 5 Brake Fluid used to lubricate the o-rings.



THESE EXTRA STEPS OF LUBRICATION MAKE A VERY DRAMATIC DIFFERENCE IN THE WEAR LIFE OF THE SEALING O-RINGS IN YOUR BAKER PREMIUM HYDRAULIC KICKER COVER AND ARE NECESSARY FOR CORRECT PART FUNCTION.

6c) Using a gentle touch, slide the piston back in the side cover until it bottoms out. Take care to not force the piston into place; in such a way that o-ring damage could occur on the edge or opening of the Hydraulic Bore.

INSTALLATION

- 1) Install the supplied BAKER ratchet gear spring, gear, hub, key, washer, and nut with blue thread lock. (refer to exploded views)
- 2) Torque the ratchet hub nut to 50-60 ft lbs.
- 3) Make sure the ratchet gear slides freely in and out with no binding. Bend the washer over the nut so it locks it into place using a mallet and chisel tip. (Figure 7, 8)

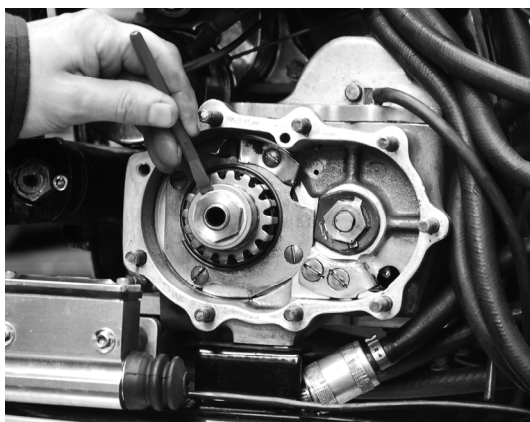

FIGURE 7 BENDING TAB OVER



FIGURE 8 SHOWN WITH TAB BENT OVER

(CONTINUED ON NEXT PAGE)

BAKER BILLET KICKER COVER KIT



IT IS CRITICAL THAT CARE IS TAKEN WHEN BENDING OVER WASHER; EXCESSIVE HAMMERING COULD CAUSE DAMAGE TO THE MAIN SHAFT OR BEARINGS

4) Install the supplied side cover gasket on the transmission at this time.

4a) **MECHANICAL COVERS:** Place the stock clutch actuator rod assembly into the hole in the end of the mainshaft on the right side of the bike in preparation for side cover installation. For early 4-Speed Transmissions with large clutch release bearing; install bearing into kicker cover at this time, making sure that the bearing is aligned with the fork. (Figure 9)

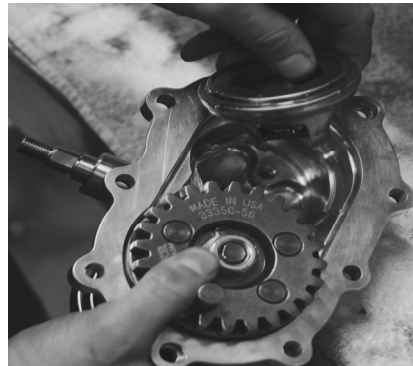

INSTALLING EARLY THROWOUT BEARING **FIGURE 9**

4b) **FOR HYDRAULIC / CABLE TYPE COVERS:** Place the provided BAKER release rod assembly in the end of the mainshaft on the right side of the bike in preparation for side cover installation. Release Rod is for 1970-E84 Models; if you have a 1936-69 Model, see page 17. Late 1984-Later Models use stock style 3pc rod setup.

5) Using the provided fasteners and washers or the stock transmission cover nuts. Install the BAKER Premium Kicker Cover using care aligning the gear teeth together. Cover should fit flush with out any tension. Torque the side cover down to 190-220 in-lbs (17-23 Nm) using 'Blue' Thread Lock while referring to the torque sequence diagram. (Figure 10)

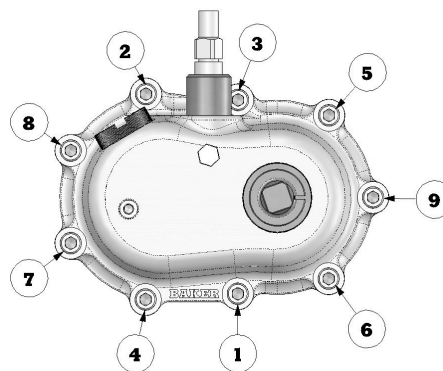

TORQUE SEQUENCE **FIGURE 10**

6) **CABLE STYLE COVERS:** Remove the six fasteners holding on the ball and ramp cover; remove the ball and ramp cover and gasket.

6a) Thread your clutch cable into the side cover. Loosen the clutch cable adjustment all the way so there is maximum cable exposed in the side cover.

6b) With the cable fully extended in the side cover take the supplied ball and ramp assembly and slide it over the cable. Install the clutch cable ferrule (PN 3094-DSSC) and 'seat' the cable; figure 11

6c) Install the ball and ramp assembly with outer ramps 'tab' in the 2 'o'clock position; figure 12

6d) Place the ball and ramp cover plate with gasket back into position. Using 'Blue' thread lock, install the six bolts. Torque the six 1/4-20 x 1/2" (PN 25C50KLHS) to 7-9 ft/lbs (84-108 in/lbs).

7) Install the kick arm return spring using care turning it clockwise (spring will be under pressure when installing) until it's locked onto the return spring stud; figure 13

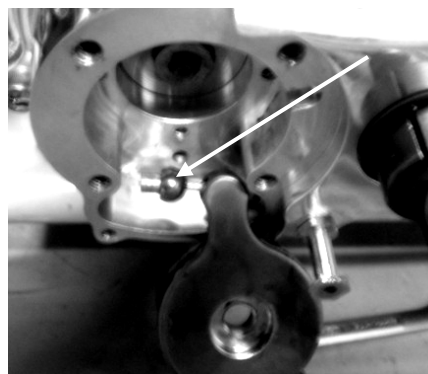

INSTALLING FERRULE ON CABLE **FIGURE 11**

(CONTINUED ON NEXT PAGE)

BAKER BILLET KICKER COVER KIT

8) **MECHANICAL COVERS:** Install your factory stock release arm and kick arm / pedal following your Factory Service Manual. Adjust your clutch per Factory Service Manual.

HYDRAULIC COVERS

FOR MECHANICAL / CABLE STYLE COVER PROCEED TO FINISH LINE PAGE 16

1) Bolt to the handlebars the 11/16" bore clutch lever assembly of your choice. Run the AN -3 brake line down to the side cover and bolt it in place with a 3/8"-24 Thread Banjo Bolt. Torque Banjo Bolt to 17-22 ft-lbs. (23-30 Nm).



TAKE THE NECESSARY TIME AND PROPER PRECAUTIONS TO ROUTE THE HYDRAULIC LINE AWAY FROM MOVING PARTS AND ANY EXHAUST PIPES THAT COULD DAMAGE THE LINE IN ANY WAY. MAKE SURE THAT YOU ARE ABLE MOVE THE FRONT END THROUGH ITS FULL RANGE OF MOTION LEFT TO RIGHT WITHOUT BINDING, KINKING OR PINCHING THE HYDRAULIC LINE. FAILURE TO DO SO COULD RESULT IN PARTFAILURE OR PERSONAL INJURY.

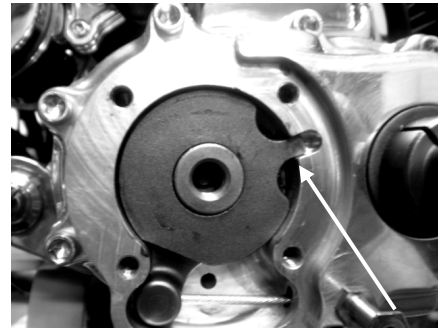

TAB SHOWN IN 2 O'CLOCK POSITION **FIGURE 12**

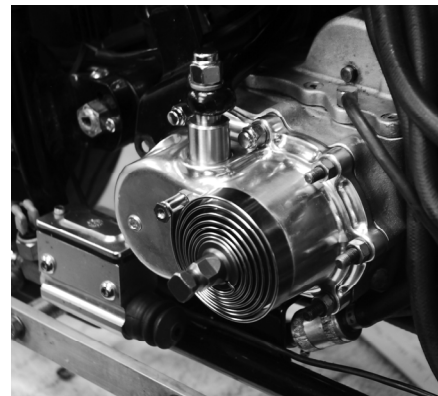

SHOWN W/ SPRING AND RELEASE ARM **FIGURE 13**

BLEEDING THE HYDRAULIC CLUTCH SYSTEM



BAKER DRIVETRAIN MAKES THE STRONG RECOMMENDATION THAT A POWER BLEEDER SYSTEM BE UTILIZED, WHETHER THAT IS A HAND OPERATED PUMP OR PNEUMATIC, TO BLEED THE HYDRAULIC CLUTCH SYSTEM ON YOUR MOTORCYCLE. IT IS THE MOST EFFECTIVE AND ONLY SUREFIRE WAY TO ENSURE THAT ALL OF THE AIR BUBBLES ARE PURGED FROM THE SYSTEM. IF YOU DO NOT OWN A POWER BLEEDER, THE FOLLOWING SET OF INSTRUCTIONS WILL ENABLE YOU TO BLEED YOUR CLUTCH SYSTEM. GREAT CARE AND ATTENTIONS NEEDS TO USED IN FOLLOWING THESE STEPS TO ENSURE A PROPERLY BLED AND FUNCTIONING SYSTEM TO ENSURE YOUR SAFETY AS A RIDER.

1) Before you can bleed the Hydraulic Clutch system you need to adjust the free play and rod length at the clutch. Using an Allen wrench, run the adjuster bolt (center of the clutch) inboard until it can be felt to bottom the piston out in the side cover. You will also know that you have hit the bottom point as the clutch will begin the move. At the point where it is fully bottomed out, back the adjuster off 1/2 to 1 full turn. The closer to the 1 full turn point that you adjust it too, the more reserve you will have in the lever before the motorcycle begins to move, with the full engagement of the clutch being proportionally closer to the end of the sweep of the lever. This amount can be adjusted to rider comfort and riding style. Tighten the jam nut to 120 in-lbs while holding the adjuster screw from rotating.

(CONTINUED ON NEXT PAGE)

BAKER BILLET KICKER COVER KIT

- 2) Place a clear tube over the bleeder valve on the side cover and run it into a clean container.
- 3) Stand the motorcycle upright so that the master cylinder on the clutch lever is level. Remove the master cylinder lid and gasket.
- 4) Add new DOT 5 Silicone Brake Fluid to the master cylinder reservoir under to the fluid level is at or below the full line. **DO NOT OVERFILL THE MASTER CYLINDER**
- 5) Squeeze the lever 5-10 times. Open the bleeder valve on the side cover and clutch fluid should flow through the tubing. If not, keep pumping the lever as it may take a few minutes for the fluid to make it all of the way through the line and cover. Once fluid begins to flow through the clear tube, close the bleeder valve. It may be necessary to add more fluid during this time even before any fluid begins to flow out of the clear tubing.
- 6) Squeeze the clutch lever and hold it against the handlebar to build up hydraulic pressure. Open the bleeder valve on the side cover about ½ turn. Clutch fluid will flow through the clear tubing. Close the bleeder when the clutch lever has traveled about 50-75% of its full travel. Wait for the clutch lever to return to its released position. Repeat step 6 as necessary until all air bubbles have been forced out of the system and there is no bubbles in the fluid within the clear tubing.
- 7) When the system has been fully bled and the clutch lever no longer feels mushy, fully tighten the bleeder valve on the side cover to 80 in-lbs. It may be necessary to fill the fluid in the reservoir to the full line at this time. **DO NOT OVERFILL THE MASTER CYLINDER.**
- 8) Place the cover back on the master cylinder and tighten down according to the control manufacturer's specifications. Check to make sure that the clutch line is tight at the clutch lever and the side cover at this time.
- 9) Replace the derby cover on the primary, referring to the Factory Service Manual for the proper tightening sequence.

FINISH LINE

- 1) Remove the fluid level plug on your new kicker cover. Remove your fill plug; fill your transmission until the fluid starts to weep out the level hole. Fluid capacity is about 20-24fl oz: BAKER Recommends: Spectro™ Heavy Duty Platinum 6 Speed Transmission Oil, P/N BD-75140-32.
- 2) Re-install your fill plug and level plugs. Re-install the exhaust if removed and double check that all fasteners are tight on the motorcycle, any ancillary parts that you removed to perform this installation are back in their intended place on the motorcycle.

Once the maiden voyage had been made around the block or down the road. Take the time to double check all fasteners and hydraulic fittings for tightness. Also with the bike as close to level as you can safely get it and the transmission fluid warmed up, double check the level of the fluid using a 3/16" Allen to remove the oil level plug. Drain off any excess fluid if the transmission is overly full. Level should be at the bottom of the hole. Re-install the oil level plug with; snug. You are complete...



SHOWN INSTALLED WITH KICK ARM AND PEDAL **FIGURE 14**

BAKER BILLET KICKER COVER KIT

RELEASE ROD MODIFICATION



BAKER SUPPLIES A 1970-E84 CLUTCH RELEASE; IF YOU HAVE A 1936-69 MODEL MODIFICATION TO THE ROD LENGTH IS NECESSARY FOR YOUR CLUTCH TO FUNCTION PROPERLY.

- 1) Refer to the figure below for your desired release rod length per model year.

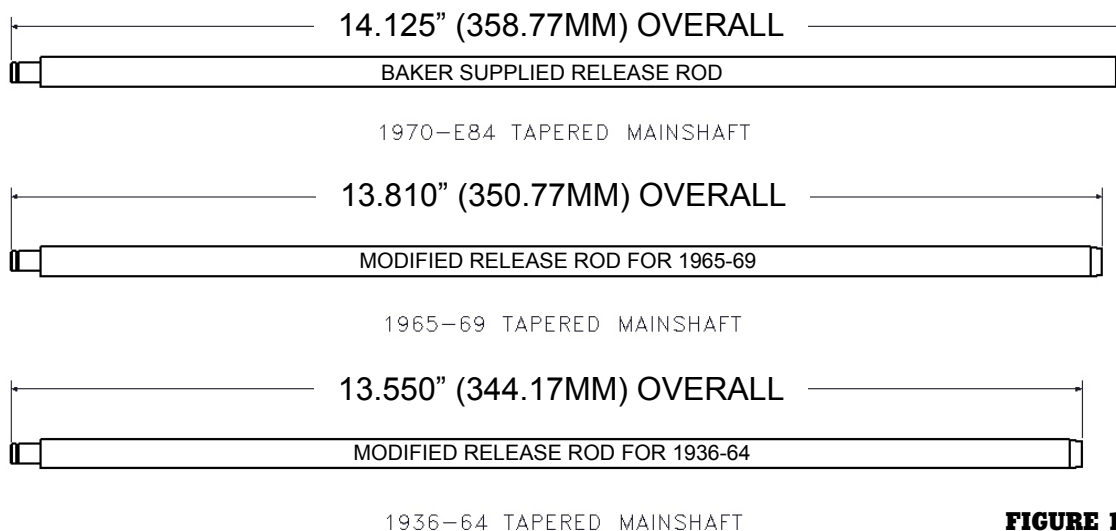

FIGURE 15

- 2) Tools required to modify parts
- Cut off wheel, chop box or equivalent
 - Belt sander, bench grinder, or file
 - Torch or map gas
 - Small container of oil
- 3) Using figure 15 cut the supplied rod to desired length; example 1965-69 models cut off 0.315" (8.00MM) or 1936-64 models cut off 0.575" (14.60MM). All measurements are within +/- 0.010" (+/- 0.25MM).
- 4) After the release rod has been cut to desired length, put a chamfer on the end to break the sharp edge, this will also to ease in the installation of the rod. Chamfer could be added using a bench grinder / belt sander or a file. Figure 16



CHAMFER ADDED TO ROD **FIGURE 16**

- HARDEN THE END OF THE RELEASE SHAFT AFTER MODIFICATION THIS WILL STRENGTHEN THE END SO THAT PREMATURE FAILURE DOES NOT OCCUR.**

- 5) **USE CAUTION AND BE CAREFUL NOT TO BURN YOURSELF DURING THIS PROCESS.** Using a torch or preferably map gas, heat the end of the rod until it starts to glow red; heat about 1.000" (25.4MM) of the rod end making sure to heat the rod evenly. Once the rod is red (cherry) quickly quench / immerse the hot end in an oil bath. Figure 17
- 6) Let the rod cool then clean the end using a Scotch-Brite™ pad or sand paper. Proceed back to page 14 for the rest of the installation.

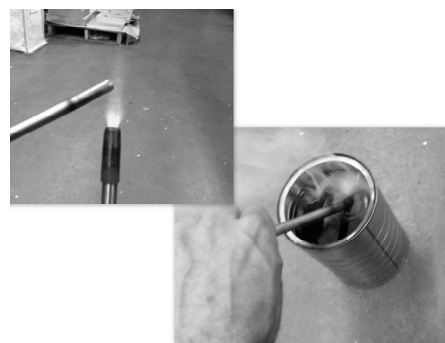

TORCH AND IMMERSE ROD IN OIL **FIGURE 17**

BAKER BILLET KICKER COVER KIT

SPECIAL ORDERS

A minimum \$500 deposit is required with all special orders. Special orders include unique case finishes, unique side door requests (i.e.; wrinkle black door or no logo).

ALL OTHER ORDERS

Orders can be pre-paid using VISA, MasterCard or American Express.

Prices shown are F.O.B. Haslett, MI. BAKER™ provides free UPS ground shipping on all retail orders for complete transmissions or transmission kit. UPS air shipment is available upon request. Customer is responsible for air shipment premiums.

LIMITED WARRANTY

BAKER™ Inc. transmission assemblies, transmission kits, and wide tire kits are guaranteed to the original purchaser to be free of manufacturing defects in materials and workmanship for a period of 2 years from the date of purchase or up to 24,000 miles - whichever is sooner.

If the product is found by BAKER™ to be defective, such products will, at the option of BAKER™, be replaced or repaired at cost to BAKER™.

In the event warranty service is required, the original purchaser must call or write BAKER™ immediately with the problem. If it is deemed necessary for BAKER™ to make an evaluation to determine whether the transmission assembly or transmission kit is defective, the entire transmission assembly, whether originally purchased as an assembly or kit, must be properly packaged and returned prepaid to BAKER™ with a copy of the original invoice of purchase.

If after an evaluation has been made by BAKER™ and a defect in materials and/or workmanship is found, BAKER™ will, at BAKER™ option, repair or replace the defective part of the assembly.

Warranty card must be returned within 45 days of purchase to be valid.

ADDITIONAL WARRANTY PROVISIONS

This limited warranty does not cover labor or other costs or expenses incidental to the repair and or replacement of BAKER™ products. This warranty does not apply if one or more of the following situations is judged by BAKER™ to be relevant: improper installation, accident, modification (including but not limited to use of unauthorized parts), racing, high performance application, mishandling, misapplication, neglect (including but not limited to improper maintenance), or improper repair.

BAKER™ shall not be liable for any consequential or incidental damages arising out of or in connection with a BAKER™ transmission assembly, transmission kit, swingarm, fender, component or part. Consequential damages shall include without limitation, loss of use, income or profit, or losses sustained as the result of injury (including death) to any person or loss of or damage to property.

BAKER™ transmissions, transmission kits, and Wide Tire Kits are designed exclusively for use in Harley-Davidson® motorcycles. BAKER™ shall have no warranty or liability obligation if a BAKER™ part is used in any other application.

If it is determined that a BAKER™ transmission assembly has been disassembled during the warranty period for any reason, this limited warranty will no longer apply.

BAKER BILLET KICKER COVER KIT

The words Harley and H-D are registered trademarks and are for reference only. Use of H-D model designations and part numbers are for reference only. BAKER Drivetrain has no association with, and makes no claim against, these words, trademarks, or companies.

It is the sole responsibility of the user to determine the suitability of this product for his or her use, and the user shall assume all legal, personal injury risk and liability and all other as well as all other obligations, duties and risks associated therewith.

CUSTOMER SUPPORT

For any installation or service questions, please contact our BAKER technical department toll free: 517-339-3835.

