



*Premium Drivetrain Products for American Motorcycles*

**MAINDRIVE GEAR &  
BEARING SERVICE KIT INSTRUCTIONS  
P/N TOOLA-56**

For

1980–Up Big Twin 5-Speed  
& BAKER 6-Speed, RSD5 and RSD6

Includes Exploded View Diagrams  
and  
Tool Installation / Usage Sequence

# Main drive gear installation and removal tools

1/2-13 X 11" bolt



1/2-13 X 7" bolt



P/N 35316-80-2 Cup, gear installation

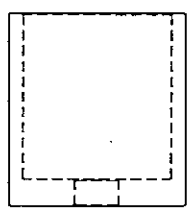

P/N 35316-80-1 Case support plate



1/4-20 X 1 SHCS

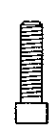

5/16-18 X 1 SHCS



Nice P/N 603 ball thrust bearing

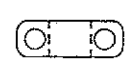

1/2" flat washer

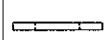

1/2-13 nut



# Main drive gear bearing installation & removal tools

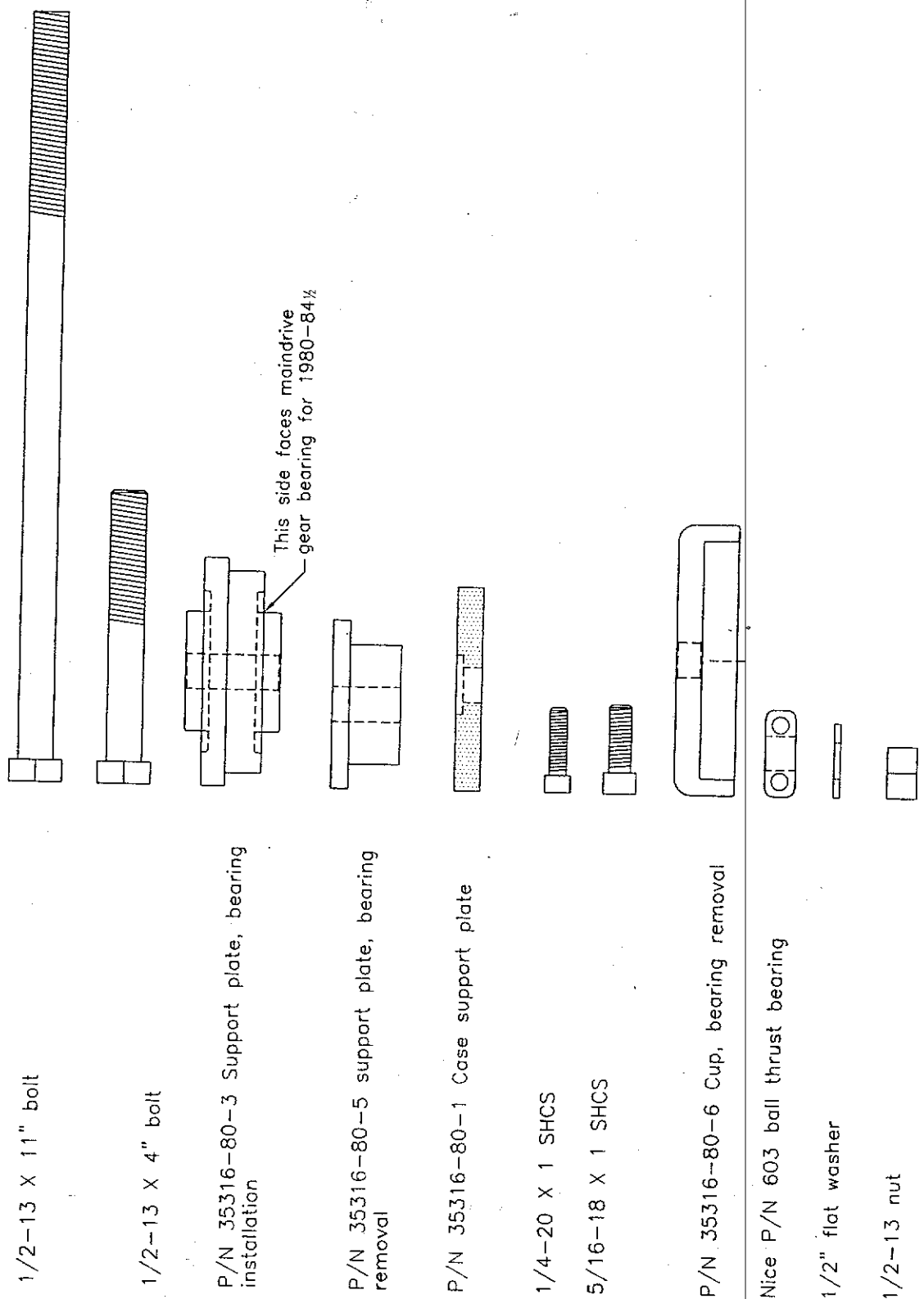

1/2-13 X 11" bolt

1/2-13 X 4" bolt

P/N 35316-80-3 Support plate, bearing installation

P/N 35316-80-5 support plate, bearing removal

P/N 35316-80-1 Case support plate

1/4-20 X 1 SHCS

5/16-18 X 1 SHCS

P/N 35316-80-6 Cup, bearing removal

Nice P/N 603 ball thrust bearing

1/2" flat washer

1/2-13 nut

Right →  
↑  
Top view

# Main drive gear bearing removal

Front of motorcycle

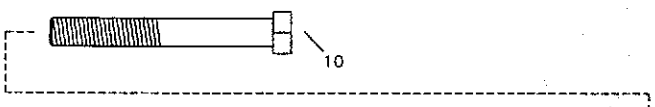

## Step 1

Install main drive gear bearing removal tools in the sequence shown.

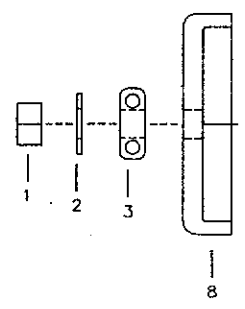

main drive gear bearing

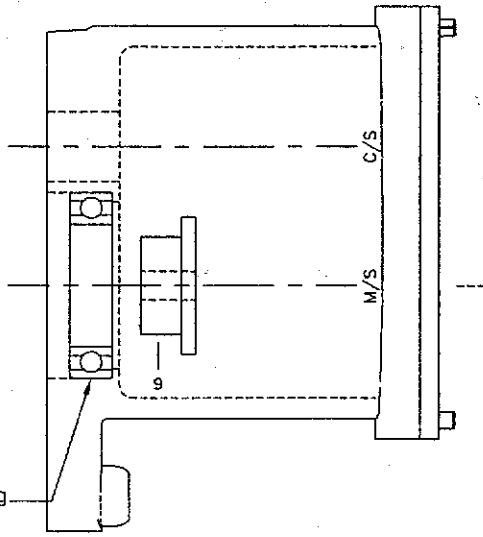

## Step 2

Tighten the nut on the draw bar by hand.

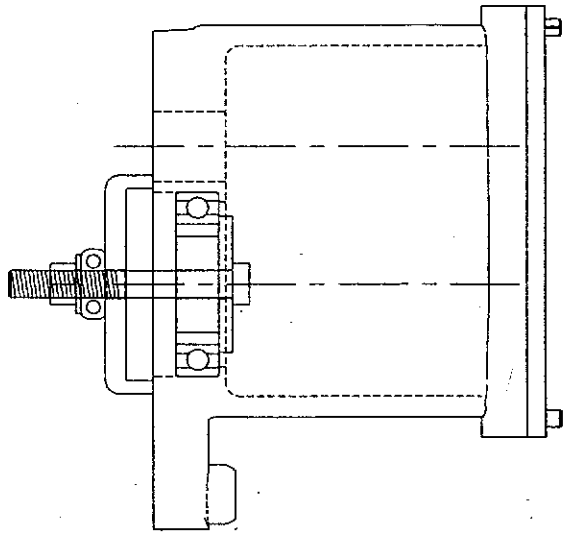

## Step 3

Tighten the nut on the draw bar with a 3/4" wrench until the bearing 'drops' out of the case

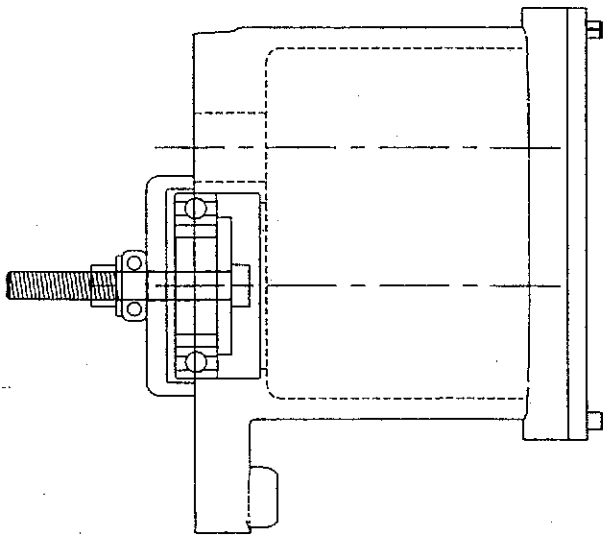

Right →

Top view

# Main drive gear bearing installation

Front of motorcycle

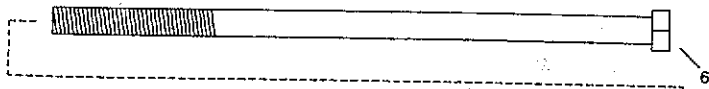

### Step 1

Install main drive gear bearing installation tools in the sequence shown. 1984½-up support plate (7) orientation (P/N 35316-80-3) shown in diagram.

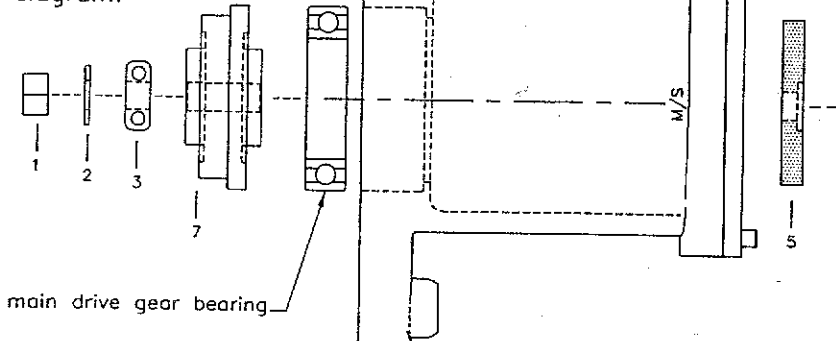

Right side view (half scale)

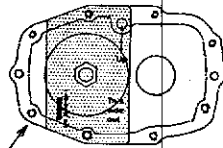

Orient support plate as shown in the right side view

### Step 2

Secure the support plate (5) to the right side as shown. Install the 1/4-20 socket head cap screw in the upper hole and the 5/16-18 cap screw in the lower hole. Tighten the nut on the draw bar with hand tools. Liberally lubricate threads during use.

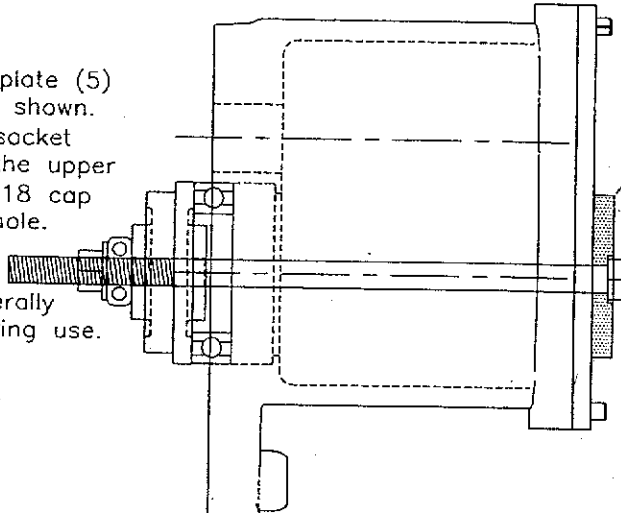

### Step 3

Tighten the nut on the draw bar until the the bearing is fully seated. Do not overtighten; the bearing seat/stop could crack or break.

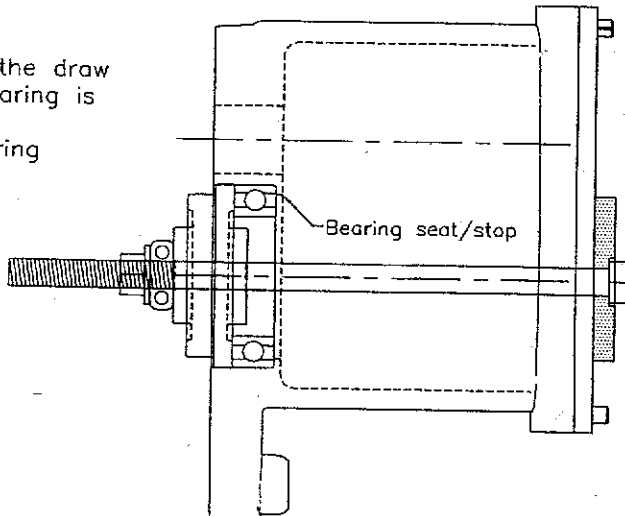

Right →

Top view

Front of motorcycle

# Main drive gear removal

### Step 1

Install the main drive gear removal tools in the sequence shown. Take care not to 'skip' the threads of the draw bar (6) across the seal in the end of the main drive gear. Orient the support plate (4) with the .030 deep counterbore facing the main drive gear.

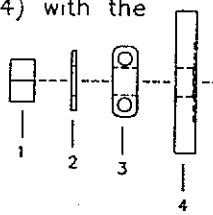

main drive gear

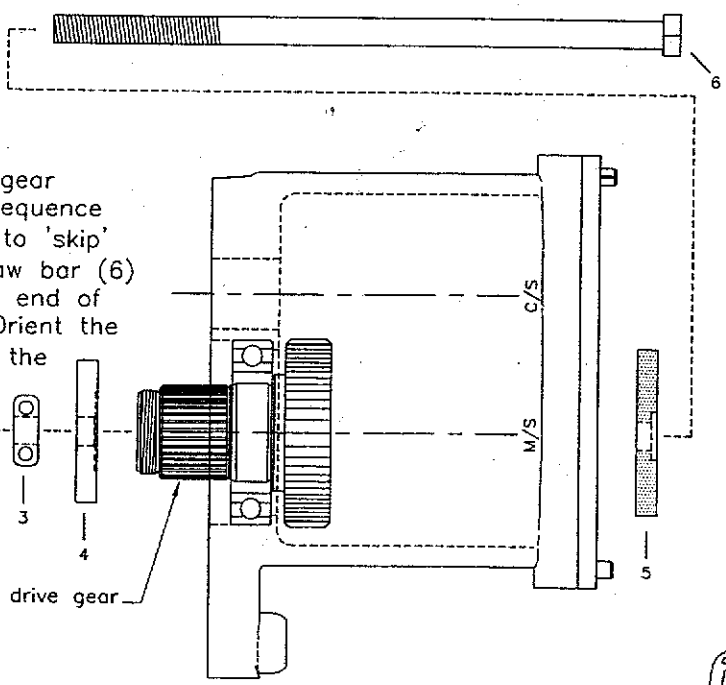

### Step 2

Secure the case support plate (5) to the right side. The 1/4-20 socket head cap screw goes on top, the 5/16-18 cap screw goes on bottom. Tighten the nut (1) on the draw bar by hand. Make sure the counterbored recess of the gear support plate (4) fits over the left end of the main drive gear.

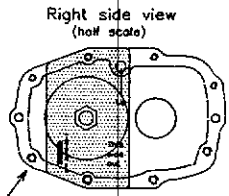
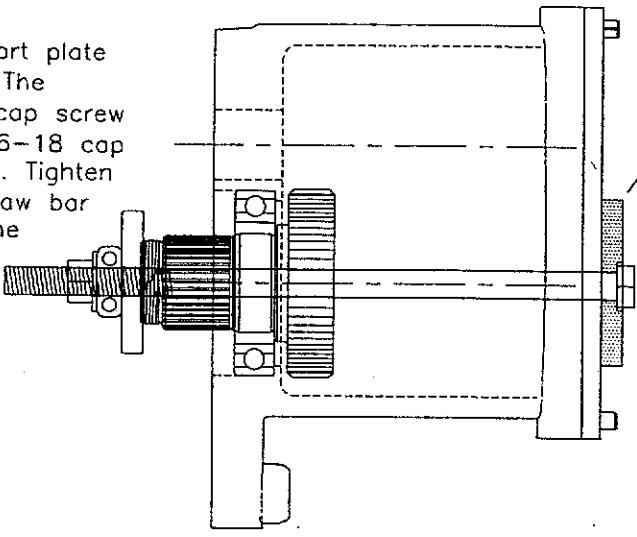

Orient support plate as shown in the right side view

### Step 3

Tighten the nut on the draw bar with a 3/4" wrench until the gear 'drops' out of the bearing.

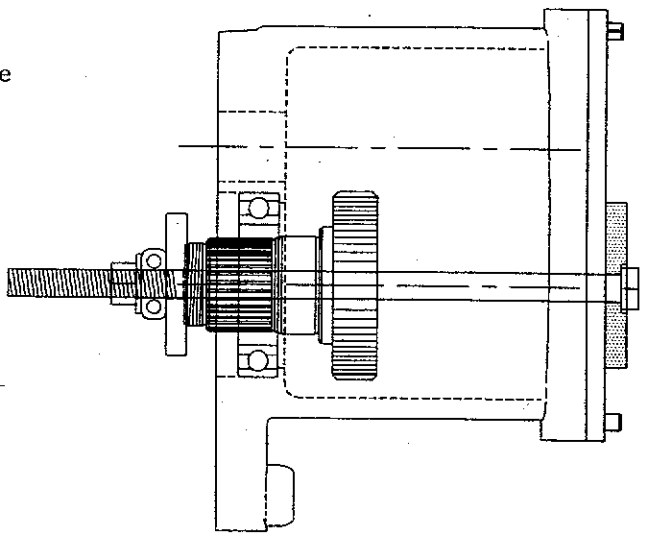

Right →

Top view

Front of motorcycle

# Main drive gear installation

## Step 1

Install main drive gear installation tools in the sequence shown. Take care not to 'skip' the threads of the draw bar (12) across the seal in the end of the main drive gear.

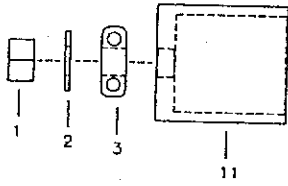

main drive gear

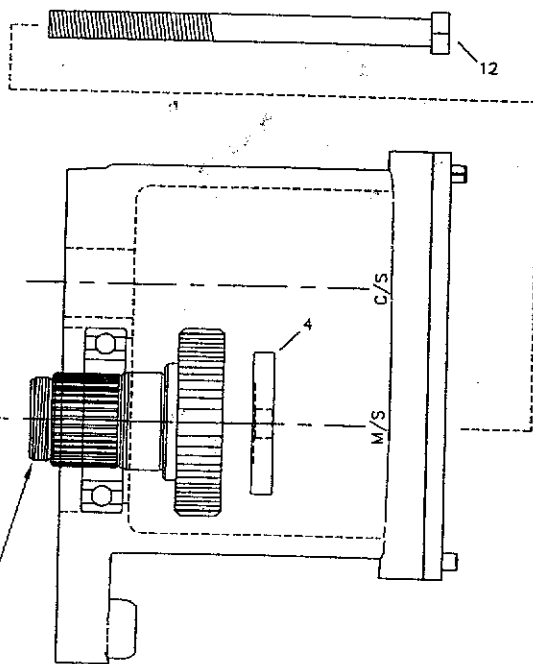

## Step 2

Tighten the nut on the draw bar by hand. Make sure the gear support plate (4) fits into the .070 deep counterbore in the right side of the gear.

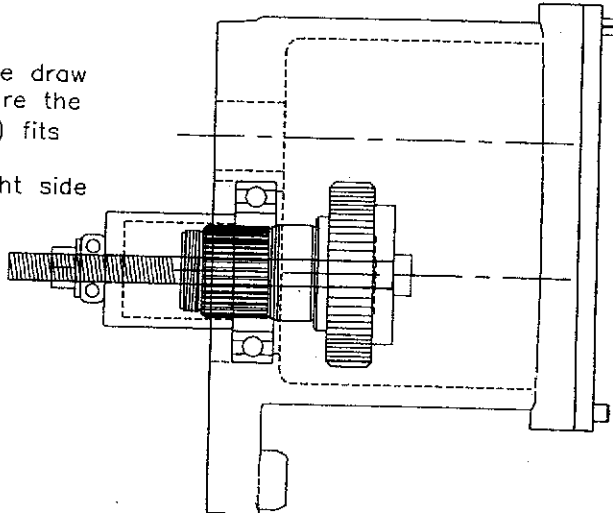

## Step 3

Tighten the nut on the draw bar with a 3/4" wrench until the gear is fully seated against the bearing.

