

BAKER DRIVE BRAKE TRANSMISSION

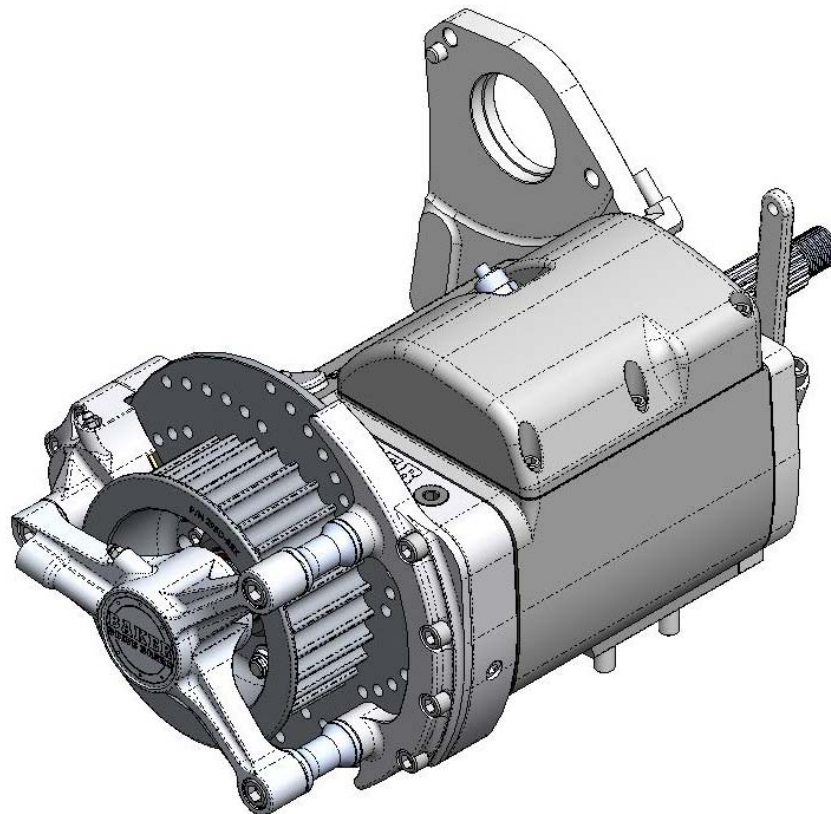
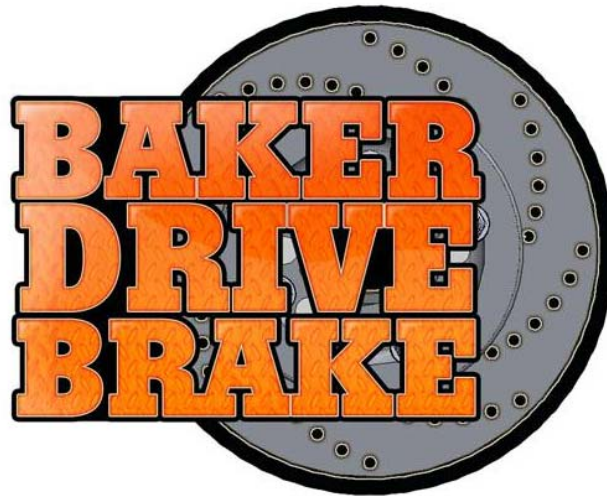

- P/N:** R701PB-BRK (Polished RSD Drive Brake Transmission with 29 Tooth Pulley)
R7211PB-BRK (Polished RSD R-Ratio Drive Brake Transmission with 29 Tooth Pulley)
R701CB-BRK (Chrome RSD Drive Brake Transmission with 29 Tooth Pulley)
R7211CB-BRK (Chrome RSD R-Ratio Drive Brake Transmission with 29 Tooth Pulley)

BAKER DRIVE BRAKE TRANSMISSION OVERVIEW

FEATURES

Most riders customize their bikes with wheels and paint to set it apart from the masses. We say show off that rear wheel you just spent thousands on with the new BAKER Drive Brake Transmission that features a fully show polished or chrome complete RSD Billet Transmission assembly. Ditching convention and forging our own path as we often do, an 8" stainless steel rotor and dual piston caliper design with dual bleeders come standard. The biggest diameter transmission mounted brake rotor on the market gives you the stopping power to slide the rear wheel out with this bad boy. The Function Formed RSD hydraulic actuator with a 1.500" piston bore and polished Stainless steel standoffs, leaves your rear wheel how it should be, seen! Available for EVO Softail®-based applications as a Standard or R-Ratio right side drive 6-speed. Additional options include N-1 Drum for those who hate trying to find neutral, A 29 tooth, .500" offset belt pulley come standard. Depending on the application or look that you are after, the top covers come with or without a neutral switch provision and case comes with or without Speedo hole.

FITMENT

- 1984-1999 EVO Softail®
- Custom Applications

TOOLS REQUIRED

- Torque Wrench (reads both in. lbs. and ft. lbs.)
- 6 Point Deep Well ¼" Drive Sockets
- 3/16" Spanner Wrench
- Common Hand Held Tools (Allen Wrenches, Sockets, Snap Ring Pliers, Etc.)
- Inner Primary Race Service Tool
 - BAKER P/N TOOLB-56
 - H-D® Equivalent P/N 34902A
- Main Drive Gear & Bearing Service Tools
 - BAKER P/N Tool A-56
 - H-D® Equivalent P/N 35316A

SPECIFICATIONS

- **TRANSMISSION FLUID CAPACITY:** 22-24 fluid oz. BAKER Recommends: Spectro™ Heavy Duty Platinum 6 Speed Transmission Oil, P/N R.HDPG6
- **COUNTERSHAFT END PLAY:** .006"-.010"
- **SHIFT DRUM END PLAY:** .000" (not adjustable)
- **PAWL ADJUSTMENT:** In 3rd Gear measurement must be equal to within .010" between pins

GEAR RATIOS

STANDARD		R-RATIO	
1 ST	2.94	1 ST	2.82
2 ND	2.21	2 ND	2.08
3 RD	1.60	3 RD	1.60
4 TH	1.23	4 TH	1.23
5 TH	1.00	5 TH	1.00
6 TH	0.86	6 TH	0.86

BAKER DRIVE BRAKE TRANSMISSION

TABLE OF CONTENTS:

- 2) Overview
- 3) Table Of Contents
- 4) Torque Values
- 5) Included Parts Breakdown Figure 1
- 6) Included Parts Breakdown Figure 1 Legend
- 7) Included Parts Breakdown Figure 2
- 8) Included Parts Breakdown Figure 2 Legend
- 9) Included Parts Breakdown and Legend Figure 3
- 10) Installation, Bleeding of Rear Brake
- 11) Bleeding Rear Brake Continued, Bleeding of Clutch
- 12) Bleeding of Clutch Continued, Maintenance
- 13) Maintenance Continued
- 14) Maintenance Continued
- 15) Terms
- 16) Disclaimer

BAKER DRIVE BRAKE TORQUE VALUES

TORQUE VALUES

THREADLOCKER / LUBRICANT

ACTUATOR

- 3/8-16 Bolt: 200-225 in-lbs (16-18 ft-lbs) Blue Loctite™ (242 Removable)

BEARING DOOR / CALIPER / FENDER SUPPORT

- 5/16-18 Bolts: 200-225 in-lbs (16-18 ft-lbs) Blue Loctite™ (242 Removable)

TOP COVER

- 1/4-20 Bolts: 100-120 in-lbs (8-10 ft-lbs) Blue Loctite™ (242 Removable)

STARTER EAR

- 5/16-18 Bolts: 200-225 in-lbs (16-18 ft-lbs) Blue Loctite™ (242 Removable)

DRUM ASSEMBLY

- 1/4-20 Bolts: 100-120 in-lbs (8-10 ft-lbs) Blue Loctite™ (242 Removable)

LOCK PLATE (PULLEY NUT)

- 1/4-20 Bolts: 100-120 in-lbs (8-10 ft-lbs) Blue Loctite™ (242 Removable)

PULLEY / SPROCKET NUT

- 50 ft-lbs (67.8 Nm) initial torque, then turn another 30-40 degrees; 45 degrees max.
Red Loctite™ (271 Permanent)

ECCENTRIC SCREW JAM NUT

- 240-288 in-lbs (20-24 ft-lbs) Blue Loctite™ (242 Removable)

SHIFT LEVER

- 5/16-24 Bolt: 200-225 in-lbs (16-18 ft-lbs) Blue Loctite™ (242 Removable)

NUT, LEFT SIDE SEAL

- 100 ft-lbs (135.58 Nm) Red Loctite™ (271 Permanent)

COUNTERSHAFT CAP

- Snug with 3/16" Spanner Wrench Pipe Thread Sealant

FILL PLUG

- 30-40 in-lbs Anti-Seize

DRAIN AND LEVEL PLUG

- 30-40 in-lbs Anti-Seize

10MM BANJO BOLTS

- 17-22 ft-lbs (23.0-29.8 Nm)

BLEEDER SCREWS

- 80 in-lbs

ROTOR BOLT NUTS

- 5/16-24 Nut: 200-225 in-lbs (16-18 ft-lbs) Red Loctite™ (271 Permanent)

BAKER DRIVE BRAKE EXPLODED VIEWS

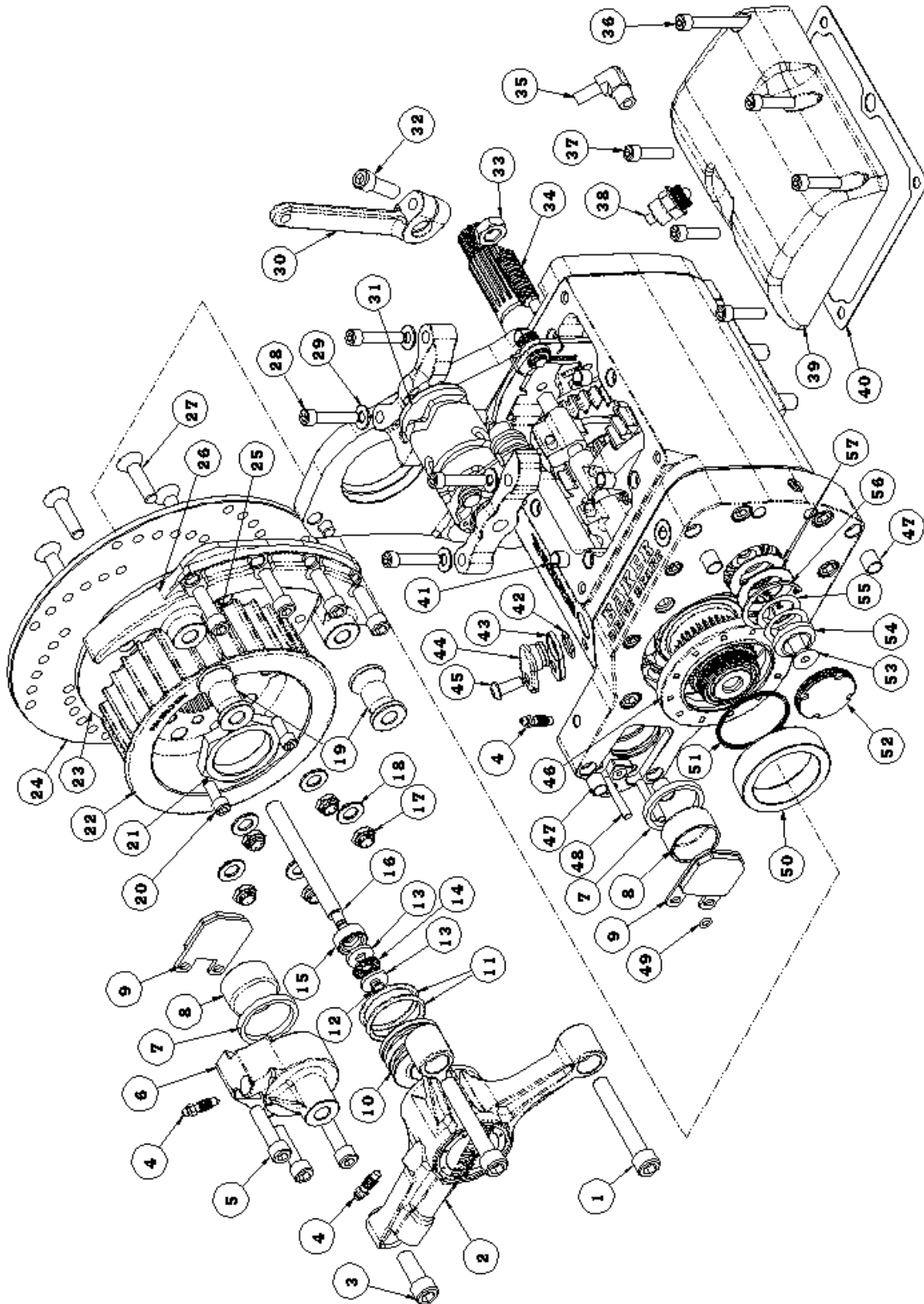

FIGURE 1

BAKER DRIVE BRAKE PARTS DETAIL FIGURE 1

ITEM	QTY	P/N	DESCRIPTION
1	2	37C250KCSS/P	3/8-16 x 2.500" Polished SHCS
2	1	114R-BRKP/C	RSD Hydraulic Actuator
3	1	37C100KCSS/P	3/8-16 x 1.000" Polished SHCS
4	3	45-9404	Bleeder Valve
5	3	31C125KCSS/P	5/16-18 x 1.250" Polished SHCS
6	1	106R-BRKP/C	Brake Caliper
7	2	0052-1200	Brake Piston Seal
8	2	0052-1410	Brake Piston
9	2	0052-1601ED	Brake Pad
10	1	124-5RA	1.500" RSD Piston, Actuator
11	2	66855	O-Ring, Hydraulic Piston
12	1	10705-01149	C-Clip, Actuator Rod
13	2	TWC411	Washer, Actuator Rod
14	1	TC411	Bearing, Thrust, Actuator Rod
15	1	3687	Seal, Actuator Rod
16	1	126-56MR	Actuator Rod
17	5	31FNXUS	5/16-24 Expanding Lock Nut S.S.
18	5	31NWSAS	Washer, .347 I.D. / .683 O.D.
19	2	108R-BRKP	Standoff, Fender Support
20	2	23202	1/4-20 x .625" SHCS
21	1	35211-91B	Nut, Pulley / Sprocket
22	1	29BD-BRK	29 Tooth Pulley
23	1	116R-BRKP	Spacer, Pulley
24	1	115R-BRK	8.000" Brake Rotor
25	4	31C100KCSS/P	5/16-18 x 1.000" Polished SHCS
26	1	105R-BRKP/C	Fender Support
27	5	31F125KFOZ	5/16-24 x 1.250" FHCS, Pulley
28	4	23207	1/4-20 x 1.250" SHCS
29	4	33001	Washer, Shift System
30	1	33715-85SA	Shift Lever
31	1	124E-OD6R-A	OD6R Shift System
32	1	31F100KCSS/P	5/16-24 x 1.000" Polished SHCS
33	1	70813	7/16-14 Jam Nut
34	1	152-56B	Eccentric Screw
35	1	62375-57C	Vent, Top Cover
36	1	25C175KCSS/P	1/4-20 x 1.750" Polished SHCS
37	5	25C100KCSS/P	1/4-20 x 1.000" Polished SHCS
38	1*	33902-98	98 Neutral Switch
39	1	104I-56P/C / 104N-56P/C	Top Cover
40	1	104TG-56	Gasket, Top Cover
41	6	609B	Alignment Dowel
42	1	66808	#014 Buna O-Ring
43	1	132-56R	Spacer, Speed Sensor
44	1	108-6EP	Plug, Speed Sensor
45	1	73753	1/4-20 x .625" Polished BHCS
46	1	12067B	Seal, Door, Main Bottle Gear
47	4	16583-67	10MM Alignment Dowel
48	2	18R125PDO	3/16 x 1.250" Solid Dowel
49	1	0073-0005	O-Ring, Caliper Seal
50	1	33344-94	Spacer, Pulley / Spacer
51	1	11165A	Quad Seal
52	1	PB14-6RP	Cap, Countershaft
53	1	24256	5/16-18 x 1.000" FHCS
54	1	35020-89	Retainer, Countershaft
55	Differ	98055A236 / 98055A234	Shims, Countershaft, Differ For Each
56	1	143RRRI	1 7/16" Internal Snap Ring
57	2	AS2035	Shim, Countershaft, Door

*** = CUSTOMER PREFERENCE, MAY NOT BE INCLUDED**

BAKER DRIVE BRAKE EXPLODED VIEWS

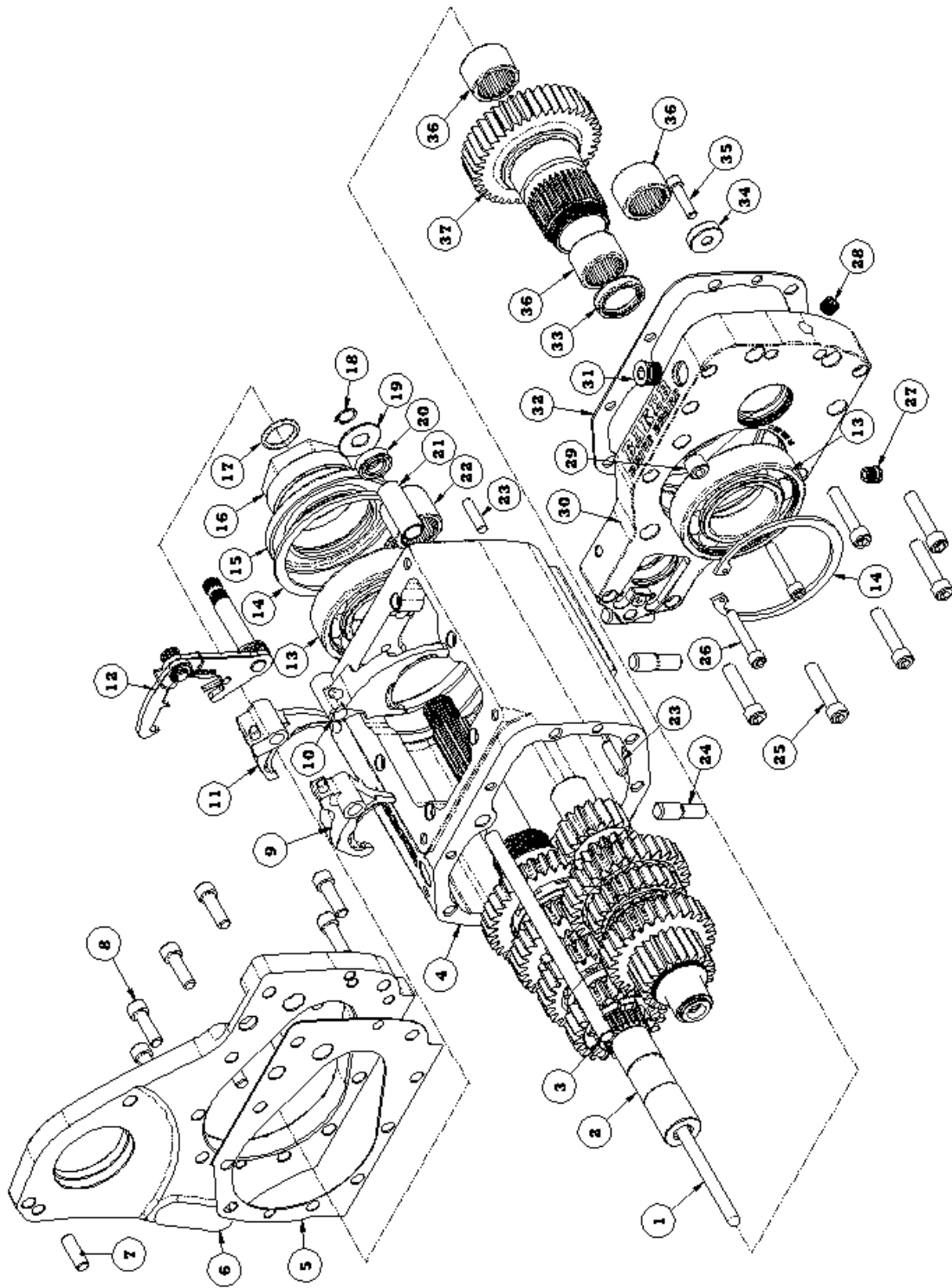
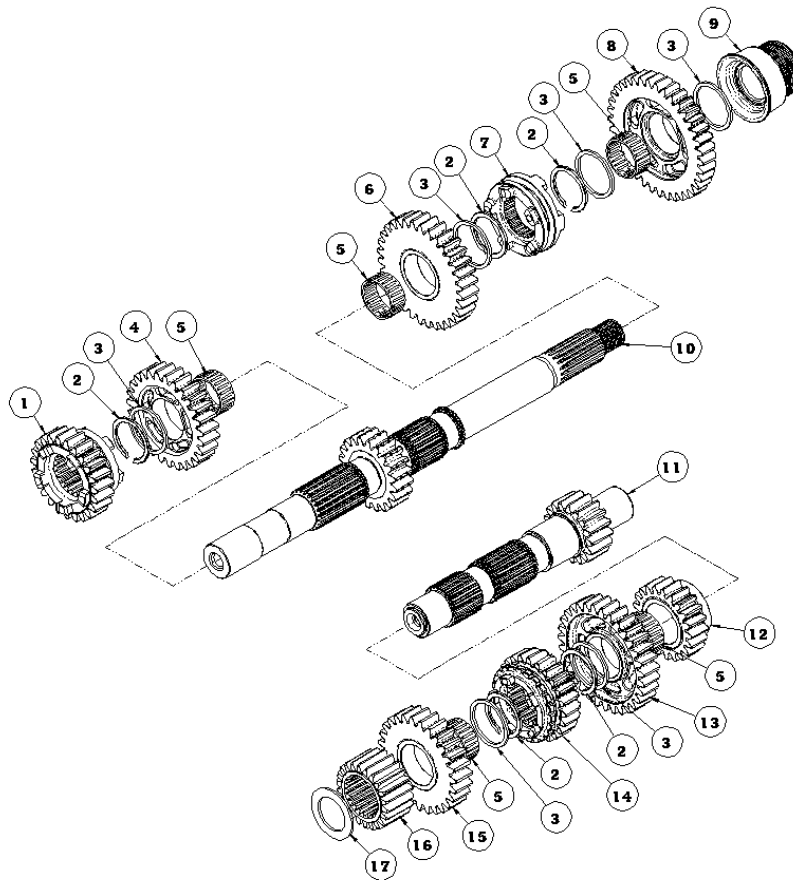

FIGURE 2

BAKER DRIVE BRAKE PARTS DETAIL FIGURE 2

ITEM	QTY	P/N	DESCRIPTION
1	1	37088-90	Clutch Release Rod
2	1	See Figure 3	OD6R Gearset Assembly
3	1	122-6R	Fork Rod
4	1	104B-56P/C	Billet Transmission Case
5	1	104D-GAS	Gasket, Starter Ear
6	1	104D-56P/C	Billet Starter Ear
7	1	26770	5/16" x 1.000" Dowel
8	9	73495	5/16-18 x 1.000" S.S. SHCS
9	1	192B-OD6R	Shift Fork, 2 nd Gear
10	1	193B-OD6R	Shift Fork, 3 rd Gear
11	1	191B-OD6R	Shift Fork, 1 st Gear
12	1	555-56C	Shifter Pawl Assembly
13	2	6209	Bearing, Main Gear, Case
14	2	VHO-334STPA	Beveled Snap Ring
15	1	12067B	Seal, Case
16	1	SK-2645	Nut, Adapter, Left Side Seal
17	1	12035B	Seal
18	1	68010	7/16" External Snap Ring
19	1	6497HW	Washer, Shifter Pawl
20	1	12045	Seal, Shifter Pawl
21	1	33114-79	Bushing, Shifter Pawl
22	1	BK2526	Bearing, Case
23	4	26751	1/4" x 3/4" Solid Dowel
24	5	11733A	Stud, Case
25	6	73497	5/16-18 x 1.500" S.S. SHCS
26	2	73464	1/4-20 x 1.500" S.S. SHCS
27	1	51740-001	3/8-24, Drain Plug
28	1	12KKPDS	1/8" NPT, Level Plug
29	1	50F50KKCS	1/2-20 Plug, Fork Rod
30	1	104R-BRKP/C	Bearing Door
31	1	22S-S06CLR	9/16-18, Fill Plug
32	1	104CG-56-.060	Gasket, Bearing Door
33	1	12035B	Seal, Main Gear
34	1	F1409	Magnet, Bearing Door
35	1	23205	1/4-20 x 1.000" SHCS Bearing,
36	3	HK2520	Main Drive Gear / Case 5 th Gear,
37	1	61005M	Main Drive

BAKER DRIVE BRAKE EXPLODED VIEWS

FIGURE 3

ITEM	QTY	P/N	DESCRIPTION
1	1	OD6R-2M / OD6R-2M208	2 nd Gear, Mainshaft
2	5	11067	Retaining Ring
3	6	6003B	Thrust Washer
4	1	OD6R-3M	3 rd Gear, Mainshaft
5	5	8876A	Bearing, Caged Needle
6	1	OD6R-4M	4 th Gear, Mainshaft
7	1	DD6-4C5	Dog Clutch
8	1	OD6R-6M	6 th Gear, Mainshaft
9	1	SK-2644	Collet, Mainshaft
10	1	OD6R-MS / OD6R-MS282	Mainshaft
11	1	OD6R-CS	Countershaft
12	1	OD6R-4C	4 th Gear, Countershaft
13	1	OD6R-1C / OD6R-1C282	1 st Gear, Countershaft
14	1	OD6R-3C	3 rd Gear, Countershaft
15	1	OD6R-2C / OD6R-2C208	2 nd Gear, Countershaft
16	1	61005CA	5 th Gear, Countershaft
17	1	15162	Washer, .062" Thick Hardened

BAKER DRIVE BRAKE TRANSMISSION

INSTALLATION:

1) Install the Drive Brake Transmission per your Factory Service Manual without installing the starter at this time.

IT IS HIGHLY RECOMMEND THAT THE REAR BRAKE LINE BE INSTALLED BEFORE INSTALLING THE STARTER. THIS WILL ALLOW ENOUGH ROOM FOR PROPER LINE INSTALLATION, DUE TO THE LOCATION OF THE FEED PORT.

2) Install the rear brake line to the transmission with 10MM banjo fitting (straight, 35, or 90 degree fitting), washers, and 3/8-24 banjo bolt. Make sure that routing of the line is secure and will not bind on swing arm or frame during riding conditions. Torque banjo bolt to 17-22 ft-lbs (23.0-29.8 Nm). Location on back side of door see figure 4.

3) Install starter per your Factory Service Manual. The BAKER Firestarter will not work with the BAKER Drive Brake Transmission.

4) Remove the transmission hydraulic actuator to install the rear belt. Install your rear belt and adjust per your Factory Service Manual.

5) Re-install the transmission hydraulic actuator as removed in step 4 using Blue Loctite™ (242 Removable). Torque bolts to 200-225 in-lbs (16-18 ft-lbs) using figure 1 for assembly reference.

6) Install hydraulic actuator line using a 9/16" quarter inch drive socket; making sure that the routing of the line does not interfere with the exhaust or belt. Using a 90 degree or 35 degree 10MM banjo fitting and a 3/8-24 banjo bolt; torque to 17-22 ft-lbs (23.0-29.8 Nm). See figure 5.

7) With the motorcycle being level, fill the transmission with 22-24 fluid oz of transmission fluid. Check transmission fluid level by removing the 1/8" NPT level plug located on the front side of the transmission door. When full the fluid will weep from hole; reinstall plug using torque value chart on page 4. Refer to pages 7-8 for location of level plug.

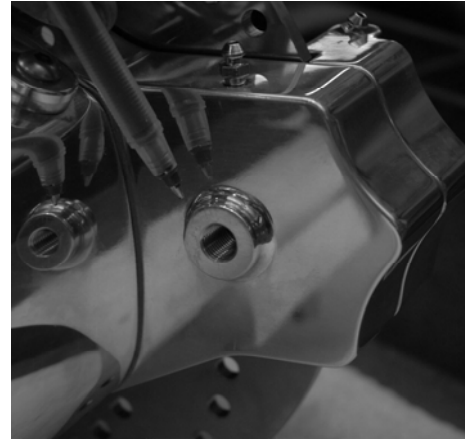

SHOWING BRAKE LINE FEED PORT **FIGURE 4**

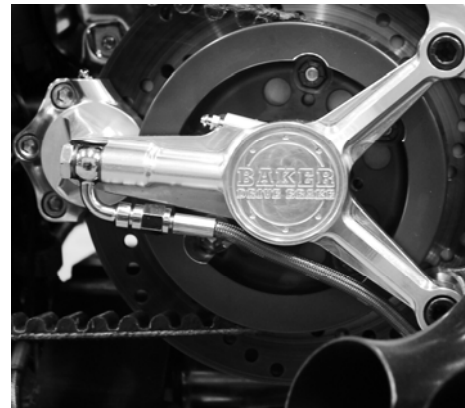

SHOWING HYDRAULIC LINE **FIGURE 5**

BLEEDING THE HYDRAULIC BRAKE SYSTEM



BAKER DRIVETRAIN MAKES THE STRONG RECOMMENDATION THAT A POWER BLEEDER SYSTEM BE UTILIZED, WHETHER THAT IS A HAND OPERATED PUMP OR PNEUMATIC, TO BLEED THE HYDRAULIC BRAKE SYSTEM ON YOUR MOTORCYCLE. IT IS THE MOST EFFECTIVE AND ONLY SUREFIRE WAY TO ENSURE THAT ALL OF THE AIR BUBBLES ARE PURGED FROM THE SYSTEM. IF YOU DO NOT OWN A POWER BLEEDER, THE FOLLOWING SET OF INSTRUCTIONS WILL ENABLE YOU TO BLEED YOUR CLUTCH SYSTEM. GREAT CARE AND ATTENTIONS NEEDS TO USED IN FOLLOWING THESE STEPS TO ENSURE A PROPERLY BLED AND FUNCTIONING SYSTEM TO ENSURE YOUR SAFETY AS A RIDER.

(CONTINUED ON NEXT PAGE)

BAKER DRIVE BRAKE TRANSMISSION

- 1) There are 2 bleeders on the brake; 1 on the door and 1 on the caliper. 1st bleed the caliper by using a 1/4" socket for a 1/4" drive ratchet. Place a clear tube over the bleeder valve on the caliper and run it into a clean container.
- 2) Stand the motorcycle upright so that the master cylinder on the rear brake lever is level. Remove the master cylinder lid and gasket.
- 3) Add new DOT 5 Silicone Brake Fluid to the master cylinder reservoir under to the fluid level is at or below the full line. **DO NOT OVERFILL THE MASTER CYLINDER**
- 4) Squeeze the lever 5-10 times. Open the bleeder valve on the caliper and brake fluid should flow through the tubing. If not, keep pumping the lever as it may take a few minutes for the fluid to make it all of the way through the line and cover. Once fluid begins to flow through the clear tube, close the bleeder valve. It may be necessary to add more fluid during this time even before any fluid begins to flow out of the clear tubing.
- 5) Squeeze the brake lever and hold it in the down position to build up hydraulic pressure. Open the bleeder valve on the caliper about ½ turn. Brake fluid will flow through the clear tubing. Close the bleeder when the brake lever has traveled about 50-75% of its full travel. Wait for the brake lever to return to its released position. Repeat step 5 as necessary until all air bubbles have been forced out of the system and there is no bubbles in the fluid within the clear tubing.
- 6) Now bleed the system from the door side repeating steps 2-5. When the system has been fully bled and the brake lever no longer feels mushy, fully tighten the bleeder valve on the caliper and door to 80 in-lbs. It may be necessary to fill the fluid in the reservoir to the full line at this time. **DO NOT OVERFILL THE MASTER CYLINDER.**
- 7) Place the cover back on the master cylinder and tighten down according to the control manufacturer's specifications. Check to make sure that the brake line is tight at the brake lever and the door at this time.

BLEEDING THE HYDRAULIC CLUTCH SYSTEM



BAKER DRIVETRAIN MAKES THE STRONG RECOMMENDATION THAT A POWER BLEEDER SYSTEM BE UTILIZED, WHETHER THAT IS A HAND OPERATED PUMP OR PNEUMATIC, TO BLEED THE HYDRAULIC CLUTCH SYSTEM ON YOUR MOTORCYCLE. IT IS THE MOST EFFECTIVE AND ONLY SUREFIRE WAY TO ENSURE THAT ALL OF THE AIR BUBBLES ARE PURGED FROM THE SYSTEM. IF YOU DO NOT OWN A POWER BLEEDER, THE FOLLOWING SET OF INSTRUCTIONS WILL ENABLE YOU TO BLEED YOUR CLUTCH SYSTEM. GREAT CARE AND ATTENTIONS NEEDS TO USED IN FOLLOWING THESE STEPS TO ENSURE A PROPERLY BLED AND FUCNTIONING SYSTEM TO ENSURE YOUR SAFETY AS A RIDER.

- 1) Before you can bleed the Hydraulic Clutch system you need to adjust the free play and rod length at the clutch. Using an Allen wrench, run the adjuster bolt (center of the clutch) inboard until it can be felt to bottom the piston out in the side cover. You will also know that you have hit the bottom point as the clutch will begin the move. At the point where it is fully bottomed out, back the adjuster off ½ to 1 full turn. The closer to the 1 full turn point that you adjust it too, the more reserve you will have in the lever before the motorcycle begins to move, with the full engagement of the clutch being proportionally closer to the end of the sweep of the lever. This amount can be adjusted to rider comfort and riding style. Tighten the jam nut to 120 in-lbs while holding the adjuster screw from rotating.
- 2) Place a clear tube over the bleeder valve on the hydraulic actuator and run it into a clean container.

(CONTINUED ON NEXT PAGE)

BAKER DRIVE BRAKE TRANSMISSION

- 3) Stand the motorcycle upright so that the master cylinder on the clutch lever is level. Remove the master cylinder lid and gasket.
- 4) Add new DOT 5 Silicone Brake Fluid to the master cylinder reservoir under to the fluid level is at or below the full line. **DO NOT OVERFILL THE MASTER CYLINDER**
- 5) Squeeze the lever 5-10 times. Open the bleeder valve on the hydraulic actuator and clutch fluid should flow through the tubing. If not, keep pumping the lever as it may take a few minutes for the fluid to make it all of the way through the line and cover. Once fluid begins to flow through the clear tube, close the bleeder valve. It may be necessary to add more fluid during this time even before any fluid begins to flow out of the clear tubing.
- 6) Squeeze the clutch lever and hold it against the handlebar to build up hydraulic pressure. Open the bleeder valve on the hydraulic actuator about ½ turn. Clutch fluid will flow through the clear tubing. Close the bleeder when the clutch lever has traveled about 50-75% of its full travel. Wait for the clutch lever to return to its released position. Repeat step 6 as necessary until all air bubbles have been forced out of the system and there is no bubbles in the fluid within the clear tubing.
- 7) When the system has been fully bled and the clutch lever no longer feels mushy, fully tighten the bleeder valve on the side cover to 80 in-lbs. It may be necessary to fill the fluid in the reservoir to the full line at this time. **DO NOT OVERFILL THE MASTER CYLINDER.**
- 8) Place the cover back on the master cylinder and tighten down according to the control manufacturer's specifications. Check to make sure that the clutch line is tight at the clutch lever and the hydraulic actuator at this time.
- 9) Replace the derby cover on the primary, referring to the Factory Service Manual for the proper tightening sequence.

MAINTENANCE / SERVICE:



BAKER RECOMMENDS CHECKING FOR BRAKE PAD WEAR AFTER THE FIRST 1 000 MILES AND 5000 MILES THERE AFTER FOR THE PROPER FUNCTION OF YOUR DRIVE BRAKE TRANSMISSION.

MINIMUM BRAKE PAD THICKNESS:	.040" (1.02mm)
MINIMUM ROTOR THICKNESS:	.190" (4.826mm)
MAXIMUM ROTOR LATERAL RUNOUT:	.008" (0.2mm)
BAKER DRIVETRAIN BRAKE PAD KIT:	P/N BRK-KIT
PERFORMANCE MACHINE KITS:	P/N 0052-1601ED P/N 0052-3001

Tools Required

- Pulley Nut Socket
 - BAKER P/N TOOLD-56
 - H-D® Equivalent P/N 94660-37B

THE DRIVE BRAKE DUAL PISTON UTILIZES PERFORMANCE MACHINE INTERNAL COMPONENTS. IF PURCHASING THE P.M. BRAKE KIT; BOTH KIT NUMBERS MUST BE PURCHASED.

CHECKING BRAKE PAD WEAR

Using a flash light or mirror check for any excessive pad wear and replace pads if necessary. Replace the brake pads if the friction material on either front or rear pad is worn to .040" (1.02mm) or less above the backing plate. Figures 6-7

(CONTINUED ON NEXT PAGE)

BAKER DRIVE BRAKE TRANSMISSION



ALWAYS REPLACE BRAKE PADS IN SETS FOR SAFE BRAKE OPERATION. IMPROPER BRAKE OPERATION COULD RESULT IN DEATH AND OR SERIOUS INJURY.

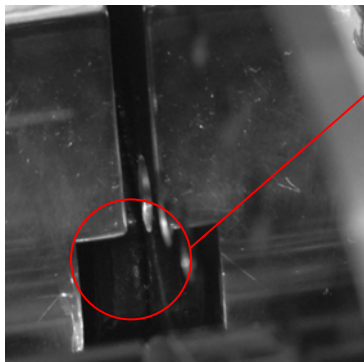

BOTH PICTURES ARE SHOWING HOW TO CHECK FOR BRAKE PAD WEAR.

FIGURE 6 LEFT PICTURE SHOWING OUTBOARD BRAKE PAD

FIGURE 7 RIGHT PICTURE SHOWING INBOARD BRAKE PAD

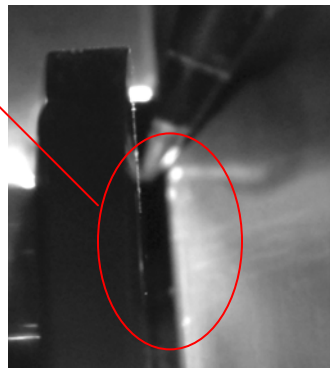

CHECKING BRAKE ROTOR WEAR

The BAKER Drive Brake Rotor is designed to last the life time of the transmission, but due to road grime, dirt roads, and your riding style you might find that your brake rotor will wear, showing grooves or pulsate due to excessive heavy braking.

Using a brake rotor micrometer measure the thickness in various areas to make sure that you are within the minimum rotor thickness of .190" (4.826mm). If the brake rotor is below the minimum thickness replace rotor. Reference exploded view Figure 1 for part numbers and description.

Using a dial indicator measure lateral runout of the brake rotor; if lateral runout is above .008" total replace rotor. Reference exploded view Figure 1 for part numbers and description.

BRAKE PAD REPLACEMENT

- 1) Safety 1st; remove your seat and disconnect your battery; disconnecting your negative battery cable first.
- 2) Remove your exhaust system; if it will interfere with removing the hydraulic actuator.
- 3) Remove your hydraulic clutch line from the hydraulic actuator using a 9/16" quarter inch drive socket. Remove the three retaining bolts holding on your hydraulic actuator using a 5/16" Allen. Remove the hydraulic actuator and standoffs.
- 4) Remove the hydraulic actuator front fender support and caliper bolts; 1/4" Allen. Using the two 3/8-16 x 2.500" bolts removed from the hydraulic actuator; thread the two bolts at least a 1/2" into the fender support by hand, wiggle the fender support off of the bearing door (figure 8). Using the same method as before thread in one of the 3/8-16 x 2.500" bolts into the caliper by hand until it bottoms out. Wiggle the caliper off of the bearing door (figure 9)
- 5) Loosen the rear wheel and drive belt by referring to your Factory Service Manual. Remove the two pulley lock screws and pulley nut; **PULLEY NUT IS LEFT HAND THREAD**. Remove the pulley /rotor assembly as seen in figure 10.

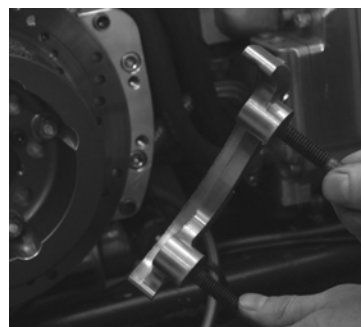

REMOVING SUPPORT **FIGURE 8**

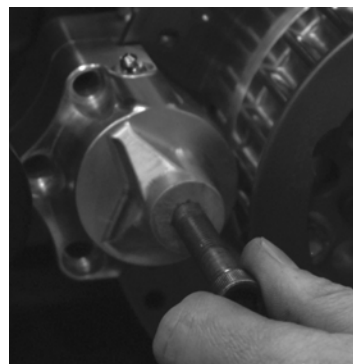

REMOVING CALIPER **FIGURE 9**

(CONTINUED ON NEXT PAGE)

BAKER DRIVE BRAKE TRANSMISSION

6) With the pulley and rotor assembly out of the way you can access the inside brake pad.

7) Before removing the old brake pad press the pad inward toward the bearing door to fully compress the piston. Do the same with the caliper you removed in step 4. This will allow enough clearance to install the new brake pads. Remove and discard old brake pads.

8) Clean off the bearing door and caliper where the brake pads slide into with a rag to clean up all the residual brake fluid that might have seeped out during step 7.

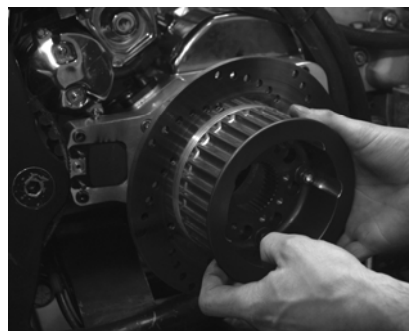

PULLEY AND ROTOR ASSEMBLY **FIGURE 10**

9) Install new inside brake pad; **DURING INSTALLATION MAKE SURE THAT THE NEW BRAKE PAD SLIDES FREELY ON THE DOWELS AND INTO THE PAD POCKET.** BAKER has found that some pads have an excessive amount of paint buildup around the dowel holes or notch of the pad. This buildup can be removed with a small file or screw driver. Figure 11

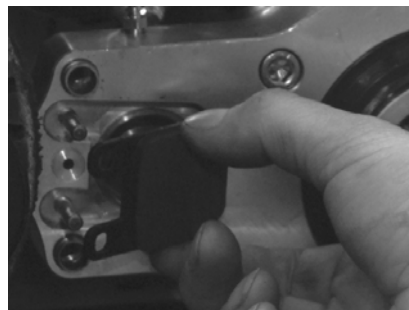

INSIDE PAD INSTALL **FIGURE 11**

10) Re-install the pulley and rotor assembly; making sure that you wrap the drive belt around the pulley during installation. Referencing page 4 Torque Values; torque pulley nut and lock screws using the correct Loctite™.

11) Slide on the outside brake pad over the dowels until its flush with the brake rotor. As mentioned in step 9, make sure that the brake pad slides freely over the dowels. Figure 12

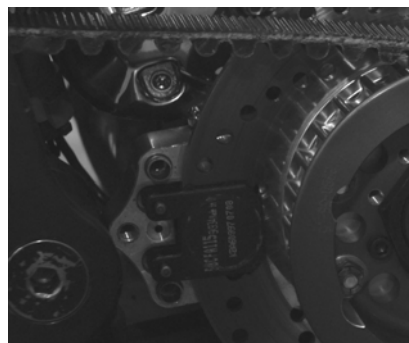

OUTSIDE PAD INSTALL **FIGURE 12**

12) Install a new transfer O-Ring lubricated with DOT 5 Brake Fluid onto the brake caliper; figure 13. Install the brake caliper with bolts referencing page 4 for the torque specifications and Loctite™ required; **SOME PATIENCE IS NEEDED TO ENSURE THAT THE O-RING DOES NOT FALL OFF OF THE CALIPER WHEN INSTALLING.** Using the two outer bolts snug them in evenly until the caliper is seated then snug the center and torque to specification.

13) Install the fender support referencing page 4 for torque and Loctite™ specifications.

14) Install the hydraulic actuator, standoffs, and hydraulic clutch line referencing page 4 for torque and Loctite™ specifications.

15) Bleed rear brake and hydraulic clutch system referencing pages 10-12. Re-adjust your rear belt per your Factory Service Manual. Servicing your Drive Brake is complete.



TRANSFER O-RING **FIGURE 13**



AFTER SERVICING THE BRAKE SYSTEM, TEST THE BRAKES AT SLOW SPEEDS FOR PROPER OPERATION; IF BRAKES ARE NOT WORKING PROPERLY, TESTING AT HIGH SPEEDS CAN CAUSE LOSS OF CONTROL, WHICH COULD RESULT IN DEATH OR SERIOUS INJURY.

BAKER DRIVE BRAKE TRANSMISSION

SPECIAL ORDERS

A minimum \$500 deposit is required with all special orders. Special orders include unique case finishes, unique side door requests (i.e.; wrinkle black door or no logo).

ALL OTHER ORDERS

Orders can be pre-paid using VISA, MasterCard or American Express.

Prices shown are F.O.B. Haslett, MI. BAKER™ provides free UPS ground shipping on all retail orders for complete transmissions or transmission kit. UPS air shipment is available upon request. Customer is responsible for air shipment premiums.

LIMITED WARRANTY

BAKER™ Inc. transmission assemblies, transmission kits, and wide tire kits are guaranteed to the original purchaser to be free of manufacturing defects in materials and workmanship for a period of 2 years from the date of purchase or up to 24,000 miles - whichever is sooner.

If the product is found by BAKER™ to be defective, such products will, at the option of BAKER™, be replaced or repaired at cost to BAKER™.

In the event warranty service is required, the original purchaser must call or write BAKER™ immediately with the problem.

If it is deemed necessary for BAKER™ to make an evaluation to determine whether the transmission assembly or transmission kit is defective, the entire transmission assembly, whether originally purchased as an assembly or kit, must be properly packaged and returned prepaid to BAKER™ with a copy of the original invoice of purchase.

If after an evaluation has been made by BAKER™ and a defect in materials and/or workmanship is found, BAKER™ will, at BAKER™ option, repair or replace the defective part of the assembly.

Warranty card must be returned within 45 days of purchase to be valid.

ADDITIONAL WARRANTY PROVISIONS

This limited warranty does not cover labor or other costs or expenses incidental to the repair and or replacement of BAKER™ products. This warranty does not apply if one or more of the following situations is judged by BAKER™ to be relevant: improper installation, accident, modification (including but not limited to use of unauthorized parts), racing, high performance application, mishandling, misapplication, neglect (including but not limited to improper maintenance), or improper repair.

BAKER™ shall not be liable for any consequential or incidental damages arising out of or in connection with a BAKER™ transmission assembly, transmission kit, swingarm, fender, component or part. Consequential damages shall include without limitation, loss of use, income or profit, or losses sustained as the result of injury (including death) to any person or loss of or damage to property.

BAKER™ transmissions, transmission kits, and Wide Tire Kits are designed exclusively for use in Harley-Davidson® motorcycles. BAKER™ shall have no warranty or liability obligation if a BAKER™ part is used in any other application.

If it is determined that a BAKER™ transmission assembly has been disassembled during the warranty period for any reason, this limited warranty will no longer apply.

BAKER DRIVE BRAKE TRANSMISSION

The words Harley, and H-D are registered trademarks and are for reference only. Use of H-D model designations and part numbers are for reference only. BAKER Drivetrain has no association with, and makes no claim against, these words, trademarks, or companies.

It is the sole responsibility of the user to determine the suitability of this product for his or her use, and the user shall assume all legal, personal injury risk and liability and all other as well as all other obligations, duties and risks associated therewith.

CUSTOMER SUPPORT

For any installation or service questions, please contact our BAKER technical department toll free: 1-877-640-2004.

