



INSTALLATION INSTRUCTIONS

FOR

BAKER 5 SPEED ROLLER SHIFT KIT

FOR 1988-1997 5-SPD BIG TWIN

PN: 171-5

PARTS PROVIDED:

See Figure 1

REQUIRED READING:

Regardless of the skill level or experience of the individual installing the Roller Shift Kit, it is highly recommended that a Factory Service Manual be available for reference for the installation. Review the part of Section 7 of your Factory Service Manual that pertains to the stock shift drum removal and installation.

INSTALLATION:

1. Remove the top cover of the transmission. Refer to your Factory Service Manual for this procedure.
2. Remove the four 7/16" hex bolts that secure the right and left pillow blocks to the case. Remove existing drum/pillow block assembly.
3. At this time, read the next section 'Modifications Require'. If modifications are required, complete them at this time.
4. Install the new BAKER Roller Shift Kit with the cap screws and washers provided. Use some "Blue" thread lock on the 1/4-20 threads.

MODIFICATIONS REQUIRED:

Stock applications of the 171-5 Roller Shift Kit require no modifications. If you have a stock top cover, resume the installation process, see step 4.

If an aftermarket top cover is used, the cover should be checked for proper fit, relative to the Roller Shift Kit hardware.

If there is an interference problem between your aftermarket top cover and the Roller Shift Kit, it will probably be between the detent level torsion spring and the aftermarket top cover. Examine this potential situation and make the appropriate changes to the inside of the top cover. Do not modify any part of the Roller Shift Kit to facilitate proper top cover fitment. Resume the installation process, see step 4 above.

**FIGURE 1
PLAN VIEW 1**

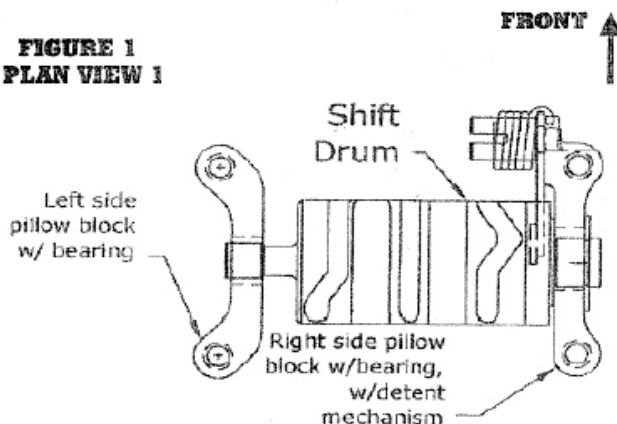

**BAKER DRIVETRAIN
9804 E. SAGINAW
HASLETT, MI. 48840
PHONE: 517-339-3835**