

# 30-TOOTH COMPENSATOR SPROCKET KIT



PN 731-67 | 731-M8 | 732-67 | 732-M8 Compensator Sprocket Kit



# 30-TOOTH COMPENSATOR SPROCKET KIT

## FEATURES

The BAKER 30-Tooth Compensator Kit features improved function, quieter operation, and extended durability over the stock Factory configuration. These improvements were achieved by increased cam lobe geometry width and ramp angles (figure 1) with adding a circular oil skirt (figure 2) that channels primary lubricant into the cam lobe region.



Figure 1, Cam Lobes

## FITMENT

- 2006 – 2017 Dyna Models & 2007-2017 Softail\* Models (PN 731-67)
- 2007 – 2016 Touring Models (PN 732-67)
- 2017 – Later Touring Milwaukee 8 Models (PN 732-M8)
- 2018 – Later Softail\* Milwaukee 8 Models (PN 731-M8)
  - Compensating Sprocket currently does not fit Softails with wide rear tires IE: 240 rear tires found on Fat Boy<sup>®</sup> Breakout<sup>®</sup> & CVO Models, etc.

## PARTS, SPECIAL TOOLS, and REFERENCE MATERIALS REQUIRED

To complete the installation of the BAKER Compensator Kit the following is required:

- A new primary cover gasket.
- T-70 Torx socket, removal and installation of sprocket assembly.
- 9/16-12 bottoming tap or thread chaser to clean the sprocket shaft female threads.
- Early Factory compensators utilized a rotor with an integral compensator spring cup. Bikes equipped with this early style rotor must be retrofitted with a PN 30041-08A late style rotor.
- 2006 Dyna must also retrofit the stator with PN 30017-07.
- Primary drive lubricant; see details on Page 5.
- Primary Drive locking tool HD-48219 (Touring models) HD-47977 (Softail/Dyna)
- These instructions make references to the Factory service manual. A service manual for your year and model motorcycle is required.

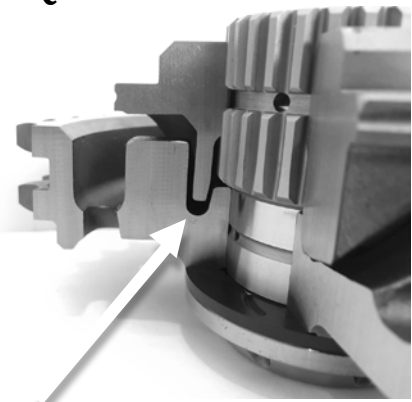

Figure 2, Oil Skirt

## HIGHLY RECOMMENDED ADDITIONAL PART

With the primary drive disassembled to install the new compensator, BAKER highly recommends that the automatic chain tensioner be replaced with a 177-67A-A Armored Attitude Adjuster (figure 3). Extensive testing and durability miles have proven that the 177-67A-A Adjuster puts less bending moment loading on the motor sprocket shaft and the transmission mainshaft thereby extending the life of the drivetrain components.



Figure 3, BAKER Armored Attitude Adjuster

# 30-TOOTH COMPENSATOR SPROCKET KIT

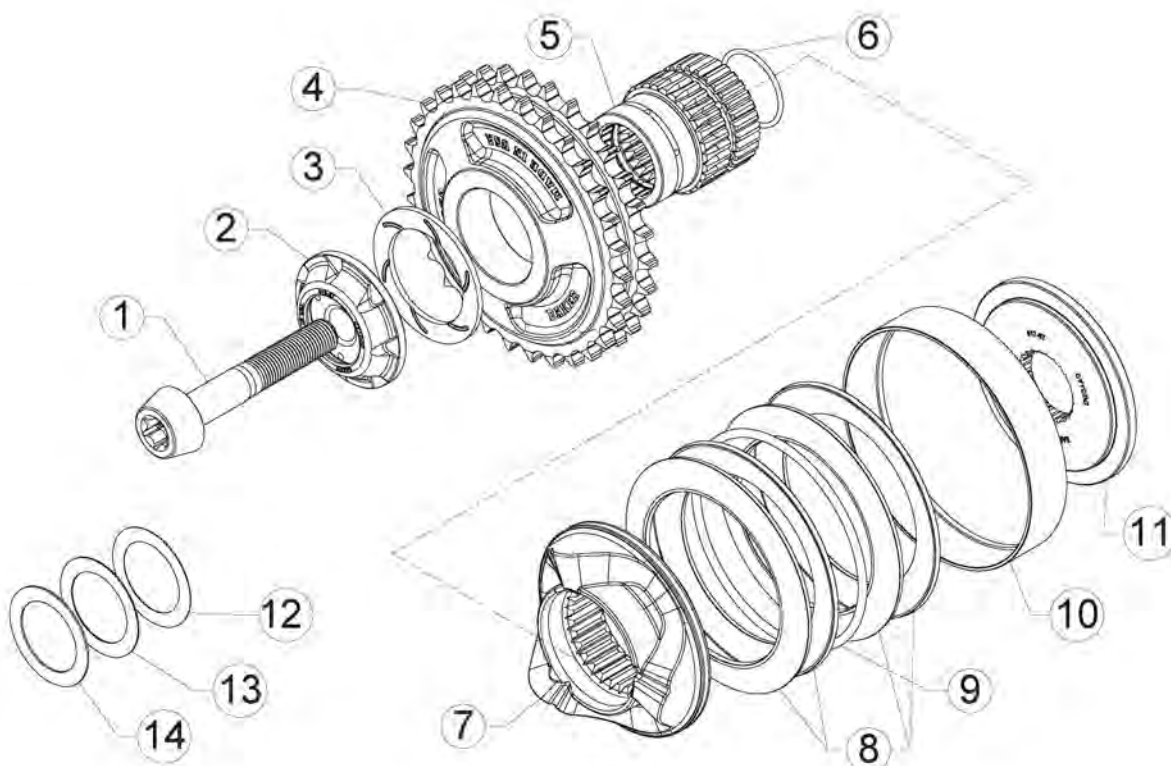

Figure 4, Detailed View

ITEM	QTY	P/N	DESCRIPTION
1	1	10500031	9/16-12, Bolt
2	1	619-67	Retainer, Comp Sprocket
3	1	BD-40100064	Thrust Washer
4	1	621-30	30 Tooth Comp Sprocket
5	1	722-67	Motor Extension Shaft
6	1	9262K682	O-Ring, 2mm x 31mm Buna
7	1	623-67-4A	Cam Slider
8	4	620-67	Belleville Spring
9	1	9452K189	O-ring, Buna-N, #239
10	1	624-67-4	Retainer, Spring
11	*1	617-67	Spacer, Spring Pack
12	1	3088A388	Shim, 1-1/4 x 1-3/4 x .020"
13	1	3088A328	Shim, 1-1/4 x 1-3/4 x .010"
14	1	3088A438	Shim, 1-1/4 x 1-3/4 x .031"
15	1	428-2-84 or 428-2-90	Primary chain, Touring-84P or Softail-90P

\*PN617-67 IS NOT SUPPLIED WITH MILLWAUKEE-EIGHT® SPROCKET KITS

# 30-TOOTH COMPENSATOR SPROCKET KIT

## REMOVAL

Remove the outer primary and existing compensator sprocket per the Factory service manual but add the following steps to the job:

- 1) We highly recommend that the stock 9/16-12 compensator bolt be heated with MAP gas, prior to removal, to soften the red Loctite®. Without the use of heat, the hardened red Loctite® may break up into pieces and act like a very coarse abrasive and destroy the bolt threads as shown in figure 5.
- 2) After the stock compensator bolt is removed, clean out the 9/16-12 female sprocket shaft threads with a 9/16-12 bottoming tap or thread chaser.
- 3) Thoroughly purge the 9/16-12 threads with lacquer thinner or brake clean and blow all debris out of the blind hole with shop air.



REMEMBER SAFETY FIRST; WEAR EYE PROTECTION WHEN USING SHOP AIR

## INSTALLATION

The 731-67, 732-67, 731-M8 & 732-M8 installs and replaces the stock factory compensator components with no modifications required.

- 1) Apply some primary lubricant to the compensator sprocket bore, cam lobes, cam slider cam lobes, motor extension shaft splines (inner/outer) and pre-installed motor extension shaft O-Ring prior to installation, figure 6.
- 2) The compensator sprocket installs in the same sequence as shipped and as shown in figure 4 (detailed view).
  - For non-Milwaukee-Eight® models, install the spacer (617-67) onto the crankshaft.
  - Milwaukee-Eight® models will not use a spacer as the spring cup will go against the stator rotor.
- 3) Install the cam slider (623-67-4) onto the motor extension shaft (722-67) and slide the spring cup assembly onto the back of the cam slider, figure 7. Make sure the lip on the spring cup faces toward the engine.
- 4) Align the crankshaft splines and extensions shaft splines and slide the assembly onto the motor crankshaft, figure 8.
- 5) Install the compensating sprocket (621-30), retainer (619-67) with thrust washer (BD-40100064) and bolt (10500031).



Figure 5, Destroyed Bolt Threads

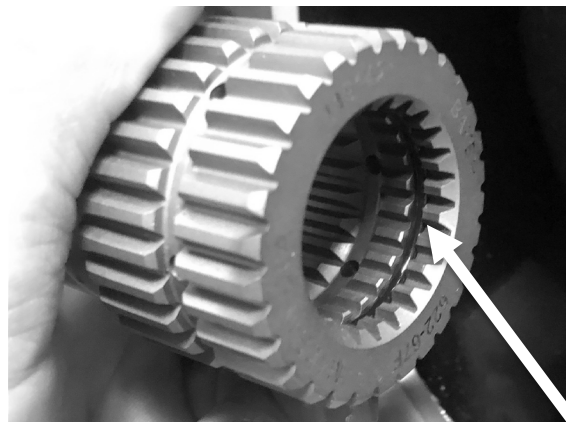

Figure 6, Oil O-Ring Inside Extension Shaft



Figure 7, Cam Slider Assembly



Figure 8, Slider Assembly Installed on Crankshaft

# 30-TOOTH COMPENSATOR SPROCKET KIT

## CHAIN ALIGNMENT:

- 1) Install just the clutch and BAKER Compensator Sprocket; NO CHAIN. Install the clutch nut and bolt (10500031); snug at this time.
- 2) Use some spacers to replicate the thickness of the outer primary and install the long 1/4-20 threaded bolt into the primary as shown in figure 9 and torque down per your factory service manual.
- 3) Place a straightedge across the end of the sprockets. With a dial caliper, measure the distance from the straightedge to the gasket surface of the inner primary. When taking the measurement, measure on the front area of the primary for the compensator and rear area for the clutch. Record this measurement. Figure 10 & 11.
- 4) Compare the two measurements taken.

**The two measurements taken (the difference) will be the spacer thickness needed (if required). Motor sprocket shims are supplied (3088A438, 3088A388, and 3088A328) to accommodate your needs.**

**If shims are required, install the shim on the crankshaft up against the stator rotor assembly before the compensator sprocket kit is installed.**

When the two measurements are .030" or less, proceed to final assembly.

- 5) Install the primary chain, clean and apply some red Loctite® to the compensator bolt (10500031) and clutch nut threads. Using a primary locking tool between the sprockets, torque the clutch nut to factory specifications following your service manual. Torque the compensator bolt (10500031) to 100ft-lbs, then back off (loosen) a half turn then re-torque to 175ft-lbs for final torque. A properly installed BAKER Compensator Sprocket looks like that shown in Figure 12.

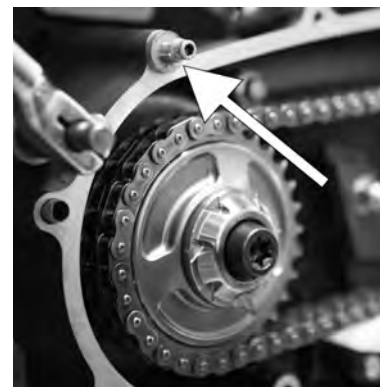

Figure 9, Spacers Shown on Long Bolts



Figure 10, Checking Comp Sprocket

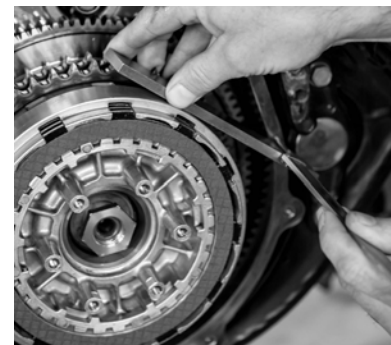

Figure 11, Checking Clutch Sprocket

## PRIMARY CHAINCASE LUBRICANT

Fill the primary per the Factory Service Manual.

BAKER recommends that Spectro Heavy Duty Primary Chaincase Oil or HD Formula+ Transmission and Chaincase Lubricant (99851-05) be used.

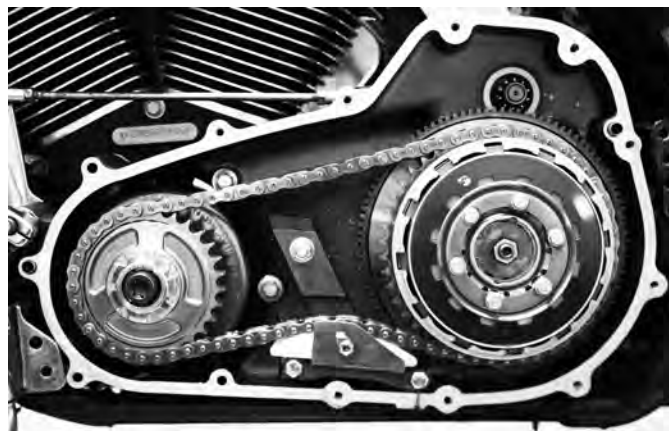

Figure 12, Installed BAKER Compensator Sprocket

# TERMS & CONDITIONS

## ORDERS

Orders can be pre-paid using VISA, MasterCard, American Express, and Discover or via wire transfer (\$30 wire transfer fee applies). All orders not pre-paid will be sent C.O.D. certified check or money order only unless pre-approved for company check acceptance. Any orders from outside the USA must be pre-paid in US funds via wire transfer (\$30 transfer fee applies).

Prices shown are F.O.B. Haslett, MI. BAKER™ ships via UPS Ground or USPS Parcel Post for all orders. UPS air shipment or USPS Priority/ Express services are available upon request. Customer is responsible for all shipping charges unless otherwise arranged at the time of sale.

## CUSTOMER SUPPORT

For any installation or service questions, please contact our BAKER technical department: 1-517-339-3835.

## LIMITED WARRANTY

NOTE: Warranty registration must be submitted within 45 days of purchase for your warranty to be valid.

BAKER™ transmission assemblies and transmission builder 's kits, are guaranteed to the original purchaser to be free of manufacturing defects in materials and workmanship for a period of 5 years from the date of purchase or up to 50,000 miles, whichever occurs first. All other BAKER products are guaranteed to the original purchaser to be free of manufacturing defects in materials and workmanship for a period of 2 years from the date of purchase or up to 24,000 miles, whichever occurs first, except for the following; Warranty does not cover clutch plate wear, throw out bearing failures or mainshaft breakage due to improper clutch nut installation.

Electrical components carry a 30-day warranty; cosmetic finishes (chrome plating, hard anodizing, powder coating) are covered for 60 days. Certain promotional products may carry a shorter warranty as specified at the time of purchase. If the product is found by BAKER to be defective, such products will, at the option of BAKER, be replaced or repaired at cost to BAKER.

In the event warranty service is required, the original purchaser must call or write BAKER immediately with a description of the problem. If it is deemed necessary for BAKER to make an evaluation to determine whether the transmission assembly or transmission kit or accessory is defective, the entire transmission assembly, whether originally purchased as an assembly or kit, must be properly packaged and returned prepaid to BAKER with a copy of the original purchase invoice. If after evaluation by BAKER a defect in materials and/or workmanship is found, BAKER will, at their option, repair or replace the defective part of the assembly.

## RETURNS AND EXCHANGES

Any merchandise returned for any reason (exchange, credit or modification) must be accompanied by a Return Goods Authorization (RGA) number or it will be refused. Call BAKER to obtain this number prior to returning goods for any reason. There is a 15% restocking fee for all returned items.

BAKER is not liable for any shipping.

## ADDITIONAL WARRANTY PROVISIONS

**NOTE: Limited warranty does not cover labor or other costs or expenses incidental to the repair and or replacement of BAKER products.**

This warranty does not apply if one or more of the following situations is judged by BAKER to be relevant: BAKER OEM transmissions ; (these are subject to the OEM manufacturers warranty only), Improper installation , accident, modification

(including but not limited to use of unauthorized parts, transmission oils or lubricants), racing, high performance application, mishandling, misapplication, neglect (including but not limited to improper maintenance), or improper repair.

BAKER shall not be liable for any consequential or incidental damages arising out of or in connection with a BAKER transmission assembly, transmission kit, component or part. Consequential damages shall include without limitation, loss of use, income or profit, or losses sustained as the result of injury (including death) to any person or loss of or damage to property.

BAKER transmissions, transmission kits and accessories are designed exclusively for use in American V-Twin motorcycles. BAKER shall have no warranty or liability obligation if BAKER parts are used in any other application.

If it is determined that a BAKER product has been disassembled during the warranty period for any reason, this limited warranty will no longer apply unless you were instructed to do so by a BAKER Drivetrain technician for diagnostic purposes.

## DISCLAIMER

The words Harley and H-D are registered trademarks and are for reference only. Use of H-D model designations and part numbers are for reference only. BAKER Drivetrain has no association with, and makes no claim against, these words, trademarks, or companies.

It is the sole responsibility of the user to determine the suitability of this product for his or her use, and the user shall assume all legal, personal injury risk and liability and all other as well as all other obligations, duties and risks associated therewith.