

POLYLINE™

POLYLINE™ Filter Housings

Rugged, all plastic housings with a choice of PVC, CPVC, PPL or PVDF construction to meet the needs of all ultra-pure or corrosive applications.

- POLYLINE filter housings have no metal components to rust, corrode or contaminate the process media. Housings are available for size 01 or 02 filter bags (PVDF 02 only).
- With a POLYLINE housing you get extra features at no extra cost such as a vent/bleed valve installed on the housing cover and an integral mounting flange for rock solid installation without the need for support legs. The two bottom pipe connections are interchangeable as outlet or drain, allowing easy modification to in-line or loop piping arrangements to accommodate any installation design.
- The hand removable, no tools required, spin off cover makes filter bag changing quick and easy. Just a few turns of the cover using the built-in handle opens and closes the housing with little effort.
- For applications that require continuous flow, duplex models are available. Here, the flow never has to be shut down for bag change-out. For contamination sensitive or severely corrosive filtration applications, a POLYLINE housing is your best choice.



PPL/PVDF models feature external cover threads



PVC/CPVC models feature true union connections



Duplex models for continuous flow applications

Operating Temperature/Pressure for POLYLINE Filter Housings

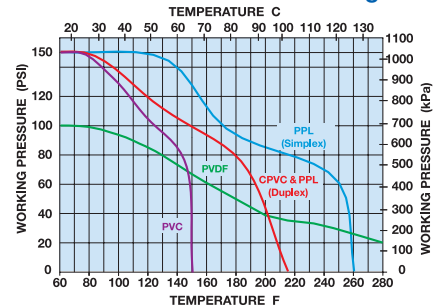

These value added features:

All plastic construction with smooth interior surfaces.

Hand removable spin off cover.

Two outlets

Duplex model available

Give these benefits

Easy to clean. Will never rust, corrode or contaminate the process media.

Fast bag change out, no tools needed to remove cover

Allows either in-line or loop piping connections with other outlet used as a drain.

Used in applications requiring continuous flow.

PVC/CPVC

PPL/PVDF

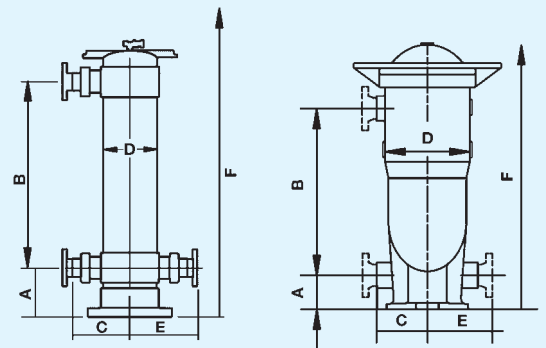

See page 5 for dimensions.

