

DB Series Duplex Basket Strainers

1/2" TO 4" PVC, CPVC, GFPP AND EASTAR®



KEY FEATURES

- PVC, CPVC, GFPP and Eastar
- No System Shutdown for Basket Cleaning
- Ergonomic Hand-Removable Cover
- In-Line or Loop Connections
- Integral Flat Mounting Bases
- External Cover Threads
- Hand Removable Vents on Covers
- Hand Removable Drains on Bodies

OPTIONS

- Stainless Steel, Monel®, Hastelloy®, and Titanium Strainer Baskets
- Pressure Differential Gauge and Switch
- Pneumatic or Electric Valve Automation
- Baskets Available with Perforated or Mesh Liners

MATERIALS

- PVC Cell Class 12454 per ASTM D1784
- CPVC Cell Class 23447 per ASTM D1784
- GFPP Cell Class 85580 per ASTM D4101
- Eastar
- FPM and EPDM O-Ring Seals

TECHNICAL INFORMATION

BASKET OPTIONS

PERFORATION SIZES	MESH SIZES	BASKET MATERIAL
1/32"	20	SSTL, Hastelloy, Monel and Titanium
1/16"	40	
1/8"	60	
5/32"	80	
3/16"	100	
1/4"	200	
3/8"	325	
1/32"	N/A	
1/16"		
1/8"		
3/16"		

SELECTION CHART

SIZE	MATERIAL	END CONNECTION	SEALS	PRESSURE RATING
1/2" – 4" (DN15 – DN100)	PVC, CPVC and GFPP	Socket, Threaded or Flanged	FPM or EPDM	150 PSI @ 70°F Non-Shock
	Eastar*			100 PSI @ 70°F Non-Shock

* End connections and assembly nuts are PVC

DB Series Duplex Basket Strainers

1/2" TO 4" PVC, CPVC, GFPP AND EASTAR®

TECHNICAL INFORMATION, CONTINUED

PARTS LIST

1. Single Stem Lateral
2. Double Stem Lateral
3. Inlet Flange
4. Cover
5. Strainer Body
6. Spool
7. Drain Plug and O-Ring
8. Vent Plug and O-Ring

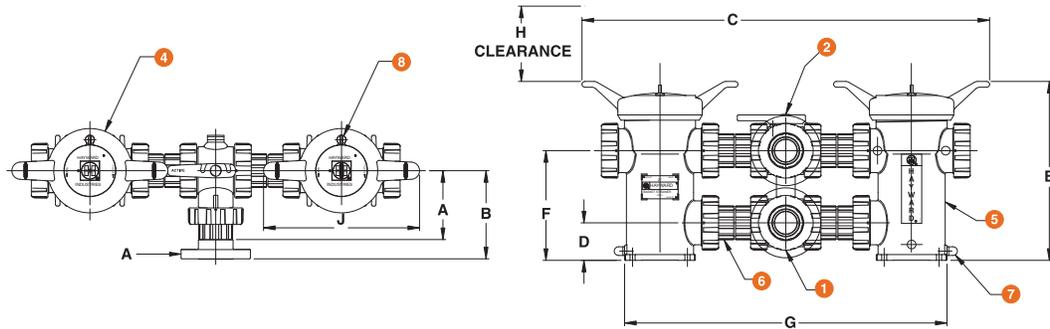

DIMENSIONS – INCHES / MILLIMETERS

SIZE in / DN	A in / mm	B in / mm	C in / mm	D in / mm	E in / mm	F in / mm	G in / mm	H in / mm	J in / mm	WEIGHT lbs / kg	
										SOC / THD	FLANGED
1/2 / 15	4.14 / 105	5.21 / 132	27.20 / 691	2.25 / 57	11.70 / 297	6.75 / 171	20.50 / 521	5.00 / 127	11.00 / 279	20.00 / 9.07	21.00 / 9.53
3/4 / 20	4.14 / 105	5.33 / 135	27.20 / 691	2.25 / 57	11.70 / 297	6.75 / 171	20.50 / 521	5.00 / 127	11.00 / 279	20.00 / 9.07	21.00 / 9.53
1 / 25	4.14 / 105	5.64 / 143	27.20 / 691	2.25 / 57	11.70 / 297	6.75 / 171	20.50 / 521	5.00 / 127	11.00 / 279	20.00 / 9.07	21.00 / 9.53
1-1/4 / 32	6.00 / 152	7.44 / 189	35.30 / 897	3.25 / 83	15.50 / 394	9.50 / 241	28.00 / 711	10.80 / 274	13.50 / 343	39.50 / 17.92	42.00 / 19.05
1-1/2 / 40	6.00 / 152	7.60 / 193	35.30 / 897	3.25 / 83	15.50 / 394	9.50 / 241	28.00 / 711	10.80 / 274	13.50 / 343	39.50 / 17.92	42.00 / 19.05
2 / 50	6.00 / 152	7.77 / 197	35.30 / 897	3.25 / 83	15.50 / 394	9.50 / 241	28.00 / 711	10.80 / 274	13.50 / 343	39.50 / 17.92	42.00 / 19.05
2-1/2 / 63	7.60 / 193	9.85 / 250	44.40 / 1128	4.83 / 123	22.30 / 566	14.83 / 377	35.60 / 904	14.80 / 376	16.00 / 406	83.00 / 37.65	88.00 / 39.92
3 / 80	7.60 / 193	9.85 / 250	44.40 / 1128	4.83 / 123	22.30 / 566	14.83 / 377	35.60 / 904	14.80 / 376	16.00 / 406	83.00 / 37.65	88.50 / 40.14
4 / 100	9.33 / 237	11.76 / 299	47.50 / 1207	4.83 / 123	22.30 / 566	14.83 / 377	38.70 / 983	14.80 / 376	16.00 / 406	100.00 / 45.36	105.00 / 47.63

Dimensions are subject to change without notice – consult factory for installation information

PRESSURE DROP CALCULATIONS

BASKET PERFORATION CORRECTION FACTORS

For 1/2" to 4" Strainers

Plastic		Stainless Steel	
1/32"	1.05	1/32"	.82
1/16"	1.00	1/16"	.74
1/8"	.58	1/8"	.58
3/16"	.46	5/32"	.37
		3/16"	.46
		1/4"	.58
		3/8"	.45
		20 Mesh	.79
		40 Mesh	1.01
		60 Mesh	1.20
		80 Mesh	1.16
		100 Mesh	1.20
		200 Mesh	1.09
		325 Mesh	1.22

PRESSURE LOSS CALCULATION FORMULA

The pressure drop across the strainer, for water or fluids with a similar viscosity, can be calculated using the formula at the right:

$$\Delta P = \left[\frac{Q}{Cv} \right]^2$$

ΔP = Pressure Drop
 Q = Flow in GPM
 Cv = Flow Coefficient

Cv VALUES

SIZE in / DN	Cv VALUES GPM	SIZE in / DN	Cv VALUES GPM
1/2 / 15	12.5	1-1/2 / 40	45
3/4 / 20	13	2 / 50	48
1 / 25	14	3 / 80	200
1-1/4 / 32	40	4 / 100	280

The above Cv Values were determined using a 1/16" perforated plastic basket in 1/2" through 4" strainers.

To calculate pressure drop through vessels using other than 1/16" perforated baskets, first calculate the pressure drop using the listed Cv, and then multiply the result by the correction factor in the Correction Factors chart to the left.

OPERATING TEMPERATURE / PRESSURE

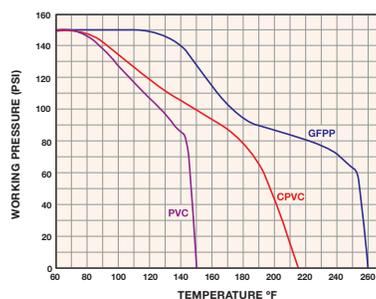

Hayward is a registered trademark of Hayward Industries, Inc.
© 2011 Hayward Industries, Inc.

– Eastar is a registered trademark of Eastman.
– Hastelloy is a registered trademark of Haynes International Inc.
– Monel is a registered trademark of Special Metals Corporation.