

# SimpleEV

▶ charge point

Quick Start Guide

the Smartest Simple Charge Point

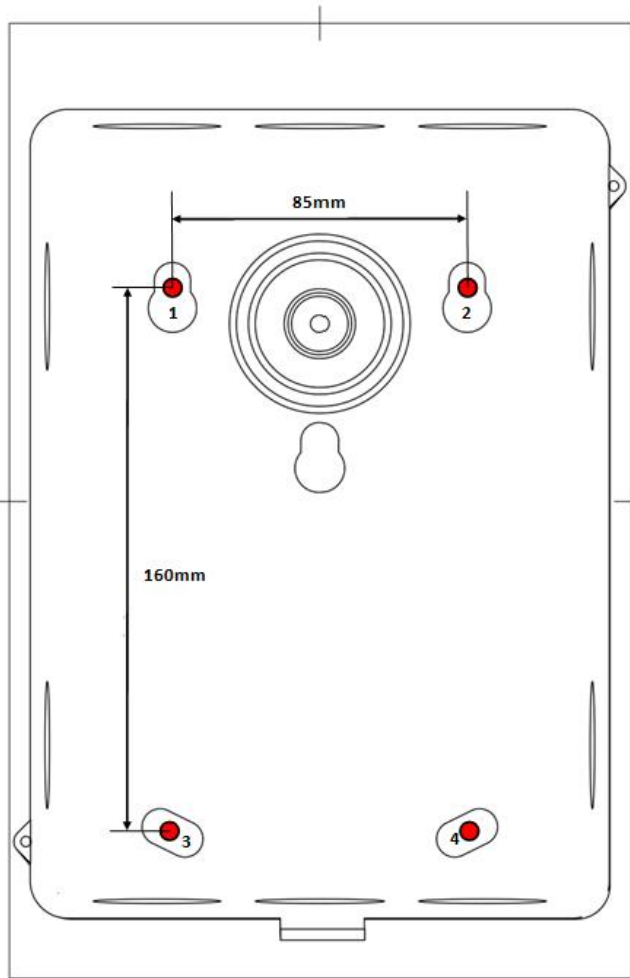

## Mounting

SimpleEV is mounted via the knockouts (use a strike-through screwdriver & hammer) indicated 1 - 4 in the image to the left.

Use the tear-off cardboard section from the packaging for a 'to Scale' drill template.

Take care to avoid damaging internal wires when fixing to the wall.

To remove the entire assembly, loosen the 2 x DIN rail retaining screws, remove the earth tag and lift & slide the DIN rail to the right to lift over the screws via keyway apertures (use a flat blade screwdriver to help).

Retain and fit the rubber covers over the fixing points.

## Cable Entry

Entry is via the 20/32mm knockouts (drillable to 25mm) available at various locations on the SimpleEV. Take care not to damage the PCB when knocking out/drilling.

NEUTRAL, EARTH & LIVE need to be connected into the spring terminals as detailed on board (insert a small tool at the end of the orange lever to open and close)

## Electrical Protection

SimpleEV has an integrated 6mA DC RCM.

Type A RCBO 30mA protection is usually recommended upstream, always check with local wiring regulations.

## Recommended Cable Spec

6mm<sup>2</sup> – 7 stranded core

## Load Balancing / Supply Optimisation (optional)

Load balancing is a feature designed to ensure that the property fuse or chosen spur cable is never overloaded. (requires 1-4 x split-core CTs - order code: SCCT-01)

Clamp the split-core CTs around the property's fuse tails or mains spur cable cores, then connect them to terminals on the internal PCB (see pg 3). Program the correct limits by adjusting dipswitches 3-6 (see pg 2).

SimpleEV will measure the overall property load (or spur cable load) and then communicate with the EV to offer only the available capacity.

Alternatively, the split-core CTs can be positioned appropriately on a spur cable to provide local load balancing with other charge points or high-current draw appliances.

## Configuration of Classic 2.0

The SimpleEV must be configured correctly via the DIP switch (located top-right of contactor). See both tables below for the positions of the DIP switch.

**Switches 1-2** tell SimpleEV what electrical installation to expect (see infrastructure & wiring configuration diagrams on page 3 to help identify requirements)

SW1	SW2	SW3	SW4	SW5	SW6	CT Configuration
OFF	OFF	X	X	X	X	L1+L2+L3+N
ON	OFF	X	X	X	X	L1
OFF	ON	X	X	X	X	L1+L2+N
ON	ON	X	X	X	X	L1+L2+L3

Factory default

**Switches 3-6** adjust the max current settings for the remote split-core CT(s)

SW1	SW2	SW3	SW4	SW5	SW6	SUPPLY CURRENT
X	X	OFF	OFF	OFF	OFF	UNLIMITED
X	X	ON	OFF	OFF	OFF	16A
X	X	OFF	ON	OFF	OFF	20A
X	X	ON	ON	OFF	OFF	25A
X	X	OFF	OFF	ON	OFF	32A
X	X	ON	OFF	ON	OFF	40A
X	X	OFF	ON	ON	OFF	50A
X	X	ON	ON	ON	OFF	60A
X	X	OFF	OFF	OFF	ON	80A
X	X	ON	OFF	OFF	ON	100A
X	X	OFF	ON	OFF	ON	Not used
X	X	ON	ON	OFF	ON	Not used
X	X	OFF	OFF	ON	ON	Not used
X	X	ON	OFF	ON	ON	Not used
X	X	OFF	ON	ON	ON	Not used
X	X	ON	ON	ON	ON	Not used

## Downrating current using IC-0V (GND)

SimpleEV can downrate the charge current using Viridian EV's IC-0V(GND) technology.

For more information and how to use this feature, view **EPC 2.0 Manual, pg 11 & 12**.

This feature works with the purpose-built DAC Board, which is available from [Ecoharmony.co.uk](http://Ecoharmony.co.uk)

The IC & GND terminals are located on the white 3-way push-fit terminal block near the contactor.

## Access Lock

A removable key can be used to prevent unauthorized access.

Turning the key to 0 / OFF will disable charging.

Factory default is 1 / ON (ensure this is on for testing)



## Infrastructure & wiring configuration diagrams

The diagrams below show how to configure Switches 1-2 based on the electrical infrastructure supply available at the property.

The below also shows how many split-core CT (order code: SCCT-01) inputs are required to enable and configure load balancing/curtailment (green circle denotes a split-core CT).

Split-core CTs can also be used on individual EVSE mains spurs to enable Supply Optimisation for multiple CPs or appliances on a priority basis.

### L1+L2+L3+N

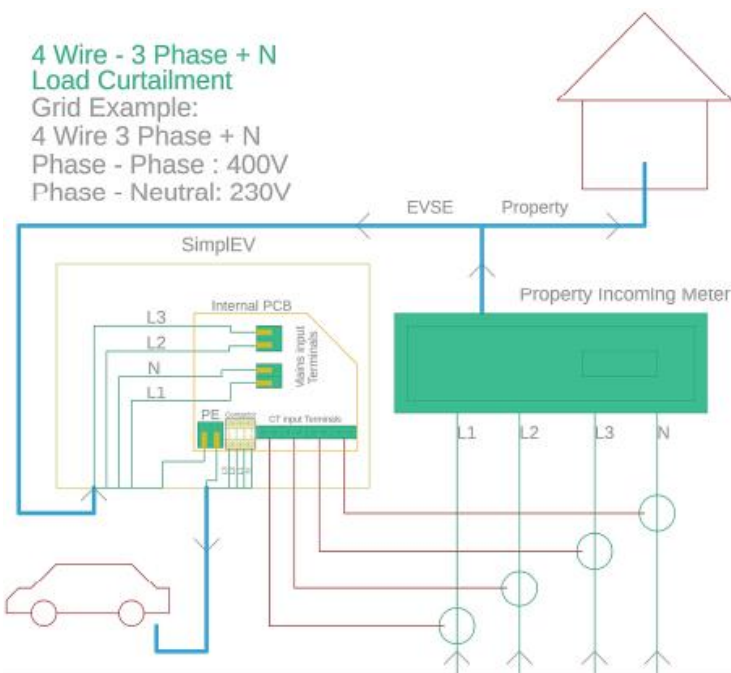

### L1+L2+L3

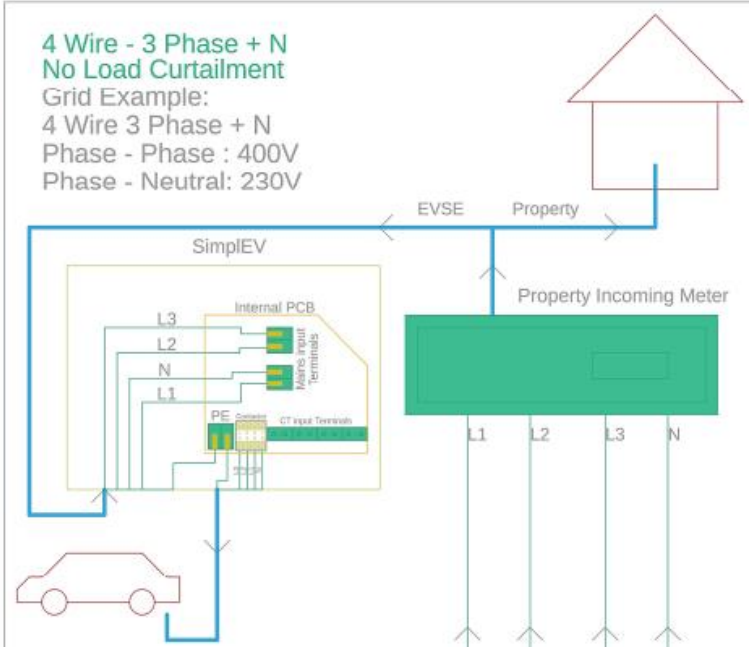
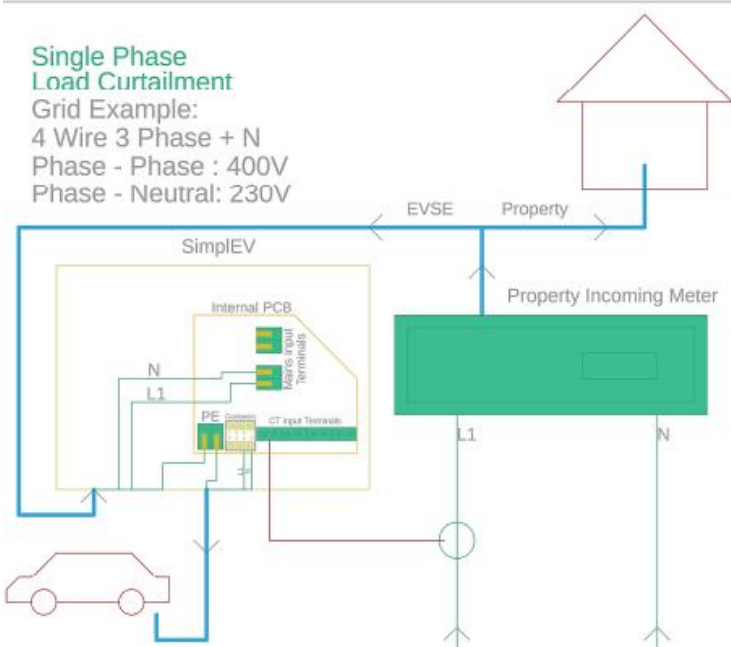
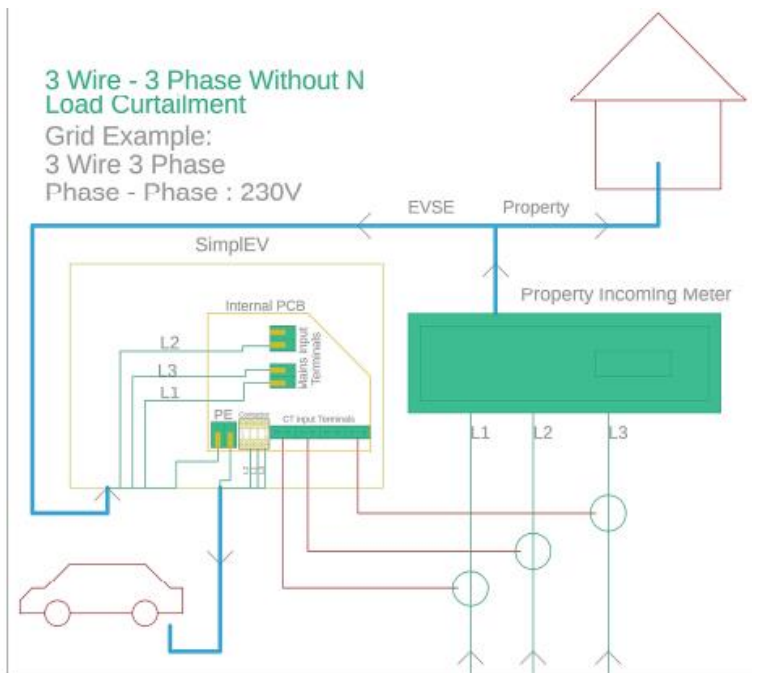

L1

No CT's required