



Luvele *deluxe* Vacuum Sealer



Instructions
LDVS175S



Congratulations

on the purchase of your new Luvele *deluxe* Vacuum Sealer

Safety Instructions

Please be sure to read all instructions before using the Luvele deluxe Vacuum Sealer. Keep these instructions for future reference.

- Remove all packaging material before using your Vacuum Sealer for the first time.
- Do not place your Vacuum Sealer near the edge of a bench or table during operation. Ensure the surface is level, free of liquids or other substances.
- Do not place your Vacuum Sealer on or near a hot stove or oven.
- Do not touch the hot sealing element located on the edge of the top cover of the Vacuum Sealer, as it may be very hot.
- Use only recommended bags and or attachments with your Luvele Vacuum Sealer, and do not use this appliance for any other purpose except for its intended use.
- Do not place any parts of the Vacuum Sealer in a dishwasher or microwave oven.
- Do not immerse the Vacuum Sealer in water or other liquids.
- Never operate damaged appliance (incl. Mains cable).
- Operate appliance only through a professionally installed socket supplying the correct voltage and do not use extension cables.
- Never remove main cable with wet hands, or lay cable on hot surface, or let cable come into contact with oil.
- Unplug the appliance after each use, when the appliance is not in use and before changing accessories or cleaning appliance.
- Do not try and perform any maintenance, other than cleaning. For any maintenance issues please contact Luvele Australia support@luvele.com.
- Do not operate outdoors.
- This appliance is not intended for use by young children or infirm persons without supervision.
- Use a fire blanket only to extinguish fires on appliance.
- The appliance is not designed for commercial or industrial use, it is for household use only. Commercial warranty claims are not valid.

Know your Luvele *deluxe* Vacuum Sealer

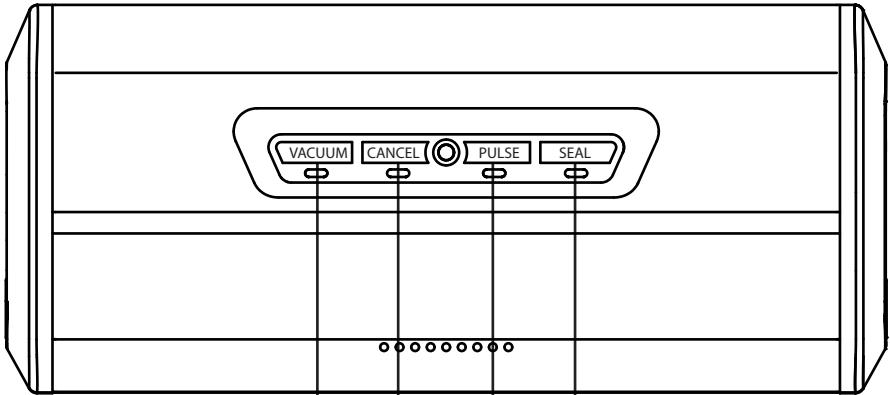

VACUUM:

When pressed in the standby mode it starts the Vacuum Sealer and commences automatic operation of vacuuming the bag and then automatically seals the bag when vacuum is complete.

CANCEL:

Immediately halts the current function.

PULSE:

The PULSE button is used when full control of the vacuuming process is required. For example, when vacuum sealing delicate, moist and liquid items less vacuuming time is required before the bag is sealed.

Alternatively, a longer vacuuming time may be required when vacuum sealing firm and hard items. The PULSE button gives full control over how long you vacuum an item before pressing the seal button. The PULSE button is a unique feature from Luvele.

Press and hold the PULSE button and the vacuum pump turns on, release the button and it shuts off. When the desired pressure is reached, press the seal button to seal the bag.

SEAL:

This button provides two functions:

First: Press to create a seal when making bags from a bag roll.

Second: Press to immediately stop the vacuum process and begin sealing the bag, preventing delicate foods from being crushed.

Know your Luvele *deluxe* Vacuum Sealer

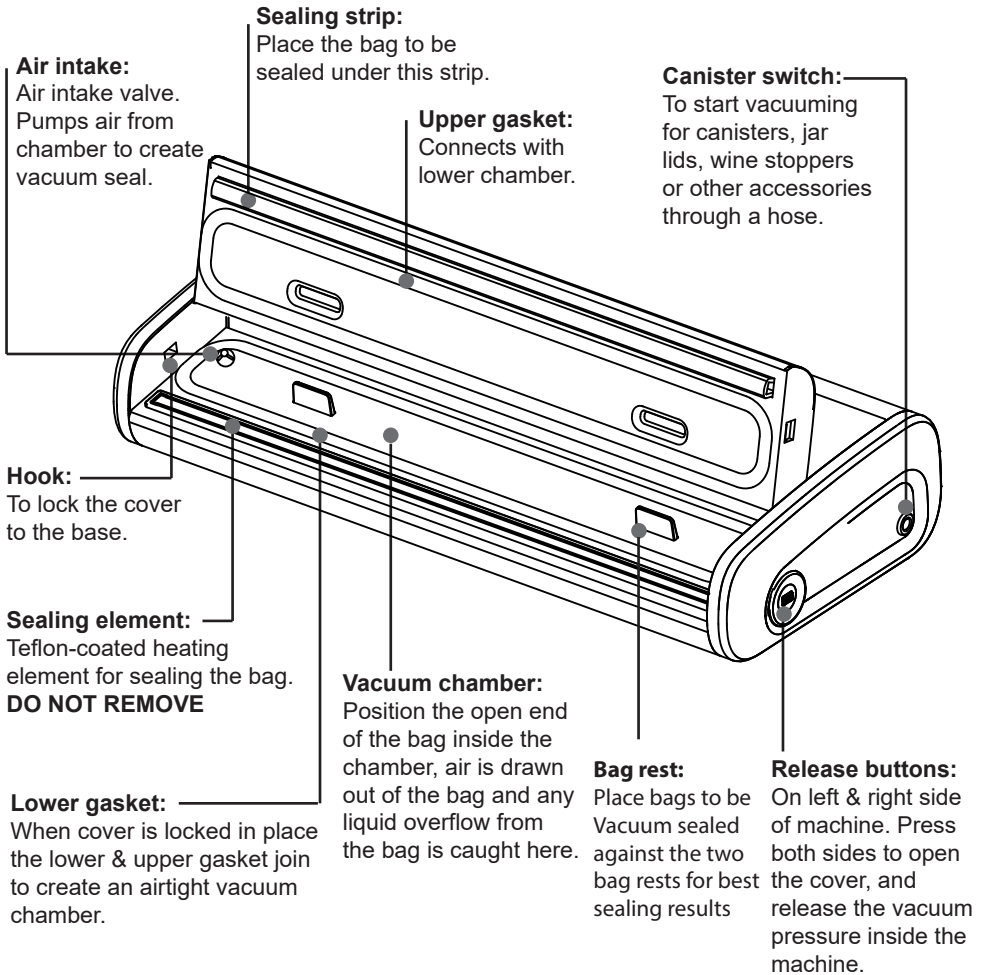

Using your Luvele *deluxe* Vacuum Sealer

Operating your Luvele *deluxe* Vacuum Sealer

Making a bag with a bag roll

1. Plug the unit into a power source.
2. Use scissors to cut a bag from the bag roll to your desired length.
3. Put one end of the bag underneath the sealing strip.
4. Close the upper lid and press tightly till you hear it click in place on both the left and right side.
5. Press SEAL button to seal one end of the bag.
6. Press the two release buttons to open the cover and take the bag out of the machine. The bag is now ready for vacuum sealing.



General vacuum packaging with a bag

1. Put the item you wish to vacuum seal inside the bag. Use only the specially designed Luvele vacuum bags/rolls supplied. Luvele high quality bags are designed with channel on both sides for more consistent vacuum sealing results.
2. Leave at least 5 - 8cm between the top of the item being sealed and the seal line to allow for bag contraction. Please note, for moist items we recommend 15cm to be left to prevent moisture from reaching the seal area. Read **Page12** for more tips on vacuum sealing liquids.
3. Straighten the open end of the bag, making sure there is no dust, liquid, wrinkles or ripples in the bag.
4. Place the open end of the bag within the vacuum chamber area. Make sure the end of the bag is pressed up against the two bag rests within the vacuum chamber.
5. Press the cover down on both sides using both hands until you hear two click sounds on both the left and right side. The cover will now be secured in place. The lid may be firm to close the first few times of use. **If needed use the palms of your hands to press down on the side to clip lid into place. After a few uses the lid/foam gaskets will loosen up.**
6. To begin the vacuum process, press the "VACUUM" button. The unit will continue to vacuum and then automatically seal once the air has been removed from the bag. Once the LED light has turned off, press the release buttons on both sides of the machine to release the bag.

Pulse vacuum packaging with a bag

1. The PULSE button is used when full control of the vacuuming process is required. For example, when vacuum sealing delicate, moist and liquid items less vacuuming time is required before the bag is sealed.
2. Alternatively, a longer vacuuming time may be required when vacuum sealing firm and hard items. The PULSE button gives full control over how long you vacuum an item before pressing the seal button. The PULSE button is a unique feature from Luvele.
3. Press and hold the PULSE button and the vacuum pump turns on, release the button and it shuts off. When the desired pressure is reached press the seal button to seal the bag.

NOTE: For the best sealing outcome, it is best to let the appliance cool down for 1 minute before using it again. Wipe out any excess liquid or food residue in the vacuum chamber after each vacuum seal.

Do not seal one bag after another continuously to avoid overheating of the sealing element. The machine will reject if "SEAL" button is pressed within 20 seconds of the last activation. Your sealer can work only on the specific bags provided by Luvele. Do not attempt to use other bags not intended for vacuum packaging. Cut the bags straight across with scissors to open a sealed bag.

Food Storage Information

Food Storage Information

Storage time will vary depending on the freshness of foods that are being vacuumed packaged. The fresher the foods the longer the storage time will be.

The main element that causes food to lose its nutritional value, texture, flavor, and overall quality is oxygen. Vacuum packaging helps to extend the life of foods by removing most of the oxygen in a sealed bag or container. Removing oxygen from stored foods helps to inhibit the growth of micro-organisms. There are three main types of micro-organisms that effect stored foods. They are mould, yeast and bacteria.

- **Mould:** Easy to identify due to its characteristics fuzz. Moulds cannot grow in vacuum packaging because of the low oxygen environment. Therefore, vacuum packaging eliminates mould.
- **Yeast:** Yeast is the fermentation of foods. It can be identified by smell or taste. Yeast requires sugar and a moderate temperature to grow and it can grow with or without air. Refrigeration will slow the growth of yeast and freezing stops it completely.
- **Bacteria:** Bacteria can grow with or without air. Bacteria results in discoloration, soft or slimy texture and an unpleasant smell. The best way to combat bacteria is to both vacuum pack and freeze foods.

Storing foods at low temperatures is critical for preserving foods safely. Growth of micro-organisms is reduced at temperatures below 4° C. Storing foods at -17°C will not kill micro-organisms but it will stop them from growing. For the best results freeze perishable foods that have been vacuumed sealed.

Thawing and heating vacuumed packages foods

Always thaw frozen foods in the refrigerator or microwave. Do not leave foods to thaw at room temperature. When microwaving a vacuumed packaged food cut a corner of the bag and place on a microwave safe tray.

You can reheat foods in a vacuum sealed bag by placing in water at a low simmer

Tips for Vacuum Packaging Food Items

Vacuum Packaging Meat & Fish

For the best results when vacuum packaging meats and fish, pre-freeze for 1-2 hours before vacuum packaging in bag. This helps meats to retain their shape and prevents any liquids from overflowing into vacuum sealer.

Vacuum Packaging Cheese

To keep cheese fresh you can vacuum pack after each use. Make the bag extra long when sealing for the first time. Cut sealed edge when you're ready to use cheese. To re-package simply place the cheese back in to the bag and re vacuum seal.

Vacuum Packaging Vegetables

Vegetables need to be blanched before vacuum packaging. This stops enzymes from effecting the flavor, colour and texture of the vegetable. To blanch vegetables, place in boiling water for approximately 1 minute. After blanching place the vegetable in to iced cold water to stop the cooking process. Then dry vegetables on paper towel before vacuum packaging.

***Note:** Cruciferous vegetables such as broccoli, Brussels sprouts, cabbage and cauliflowers naturally emit gases during storage. Therefore, after blanching and vacuum packaging they must be stored in freezer only. Mushrooms and garlic should not be vacuumed packed.*

Vacuum Packaging Fruits

Fruits can be vacuumed sealed whole or sliced. For longer lasting storage place fruits in freezer.

Vacuum Packaging Coffee or Powdery Foods

To prevent food particles from being drawn into vacuum pump place a coffee filter or piece of paper towel at the top of bag before vacuum packaging. You can also place the food in its original bag inside a vacuum sealer bag.

Vacuum Packaging Liquids

Before vacuum packaging liquids such as stock, pre-freeze in a ice cube tray until frozen. Place frozen cubes into vacuum sealer bag. When ready to use place frozen cube straight in to dish being prepared.

Vacuum Packaging for Marinating

Vacuum sealing opens the pores in foods such as meats, poultry and seafood absorbing marinades much faster than traditional methods. When vacuum sealing marinades do not overfill bag. This will ensure that liquid does not enter the vacuum chamber.

Re-sealing Chip Packets

You can utilise the seal strip to re-seal packaging that has already undergone a commercial quality seal. This allows half consumed packets of chips, crackers and cereals to be resealed by placing on sealing strip. When resealing, ensure that the bag does not reach into the vacuum chamber, as it will crush delicate items. Use this method to re-seal suitable packets only.

Vacuum Packaging Non-Food Items

The Luvele deluxe Vacuum Sealer can also be used to protect non-food items from corrosion, oxidation and moisture. The same process can be used to vacuum seal non-food items as food items.

Vacuum Packaging Silver Ware & Cutlery

When vacuum packaging silver ware and cutlery make sure any sharp edges are covered with a soft cushioning material such as paper towel to avoid puncturing bag.

Vacuum Packaging First Aid Kits

Vacuum packaging first aids kits to store in your home, boat or car is a great way to keep items dry and free from dirt and mould. Also consider vacuum sealing flares, batteries, flashlight, candles and matches.

Vacuum Packaging for Outdoor Activities

When camping vacuum packing your clothes can save space in your bag and keep dry at the same time. Also, vacuum seal your maps, matches and snacks.

Vacuum Packaging paint brushes

When painting around the home you can vacuum package your wet paint brushes between coats rather than washing. This is particularly useful for oil based paints that require mineral turpentine to clean.

Vacuum Packaging Ice

You can vacuum package ice to use as an icepack for picnics and other outdoor activities. When the ice melts you then have fresh drinking water or refreeze to use again as an icepack

Troubleshooting

Nothing happens when I try to vacuum seal a bag

- Check power cord to see if it is firmly plugged into electrical outlet.
- Examine power cord for any damage.
- See if electrical outlet is functioning by plugging in another appliance.
- If your appliance has a mode switch, make sure it is set to the correct mode. Refer to the above operating instructions
- Make sure the bag is placed correctly inside the Vacuum chamber and pressed against the bag rests.
- Make sure both sides of the cover have been clipped into place. A firm pressing down on the left and right hand side of the cover is required to achieve the sides to click securely. The vacuum sealer will not begin operation otherwise.

Air is not removed from the bag completely

- To seal properly, the open end of the bag should be resting entirely inside the vacuum chamber area.
- It is important that the bag does not wrinkle at the seal like when vacuum sealing. To prevent this from happening make sure there is at least 5 cm of bag roll between the top of the item being sealed and the seal line. The bag must be completely flat on the seal line.
- Check the sealing strip and the foam gasket are free of debris and in their correct position. Make sure there is no damage to the foam gaskets, both the upper and lower gaskets. Also, make sure the foam gaskets are flat in their respective groves. If needed, wipe clean and smooth them back into place gently with your fingers.
- Vacuum bag may have a leak. To test, seal the bag with some air in it, submerge in water, and apply pressure. Bubbles indicate a leak. Reseal or use another bag.
- Use only the specified 'double sided' vacuum bags with vacuum channels provided by Luvele.
- Leaks along the seal can be caused by wrinkles, debris crumbs, grease or liquids. Reopen bag, wipe the top inside of the bag and smooth it out along the sealing strip before resealing.

Air has re-entered into the bag after being sealed

- Leaks along the seal line can be caused by wrinkles, crumbs, grease or liquids. Reopen bag, wipe inside of the bag and smooth it out along the sealing strip before resealing.
- The release of natural gases or fermentation from foods such as fresh fruits and vegetables may occur. Most vegetables require blanching prior to vacuum packaging. See page 9 for further instructions.
- Open bag if you think food has begun to spoil, and discard food. Lack of refrigerator or fluctuating temperatures in the refrigerator can cause food to spoil. If food is not spoiled then consume food immediately.
- Check the bag for a puncture or hole which may have released the vacuum. Do not vacuum seal hard items with sharp points like bones or shell. Cushion sharp edges in the contents of the bag with paper towels.

Troubleshooting

The bag melts

- If the heating element overheats and melts the bag, it may be necessary to lift the lid and allow the heating element to cool for a few minutes.

Vacuum Sealing moist or liquid items

Many troubles faced when vacuum sealing are from trying to seal moist or liquid items. Moist items are more difficult to vacuum seal because the moisture in the items naturally wants to get sucked towards the seal area where the vacuuming is taking place. If the moisture reaches the seal area the vacuum sealer will automatically start to seal the item. This can happen while there is still air in the bag and can give the appearance that the vacuum sealer is not working correctly.

Following are some tips to overcome this:

- If attempting to seal moist meats like fish and chicken, it is recommended that you cut you vacuum bag with extra length, so there is room for the moisture to move during the vacuuming process and so the moisture does not reach the seal area. 10cm should be enough length from the end of the meat item to the seal area.
- Another solution to sealing high moisture items is to wrap them in plastic wrap then place them in the vacuum bag to be vacuum sealed. This should prevent most of the liquid being sucked towards the seal area.
- If placing large moist items in a bag like a whole fish, it is very important you do not leave any moisture near the seal area. Once you have placed this type of item in the bag, use some dry paper towel to wipe down the seal area for a successful outcome.
- Liquid items like soups, stocks, gravy etc should all be frozen before attempting to seal with a bag.

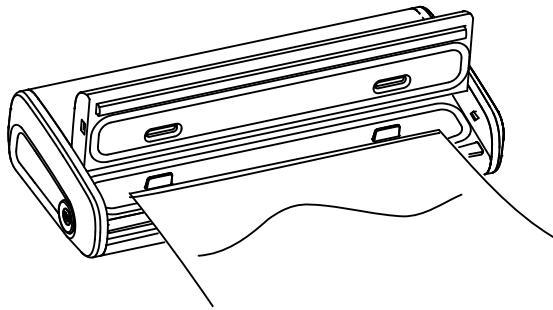

Storage and Cleaning

Cleaning your Vacuum Sealer

1. Always unplug the unit before cleaning.
2. Do not immerse in water or any other liquid.
3. Avoid using abrasive products or material to clean the unit, as they will scratch the surface.
4. Use a mild dishwashing soap and a warm, damp cloth to wipe away food residue on or around components.
5. Dry thoroughly before using again.

Note: *The foam gaskets around the vacuum chamber should be cleaned & dried thoroughly before storing. Do not store the Vacuum Sealer with the lid clipped shut as it will compress and damage the foam gaskets.*

Cleaning vacuum bags

1. Wash bags in warm water with a mild dishwashing soap
2. When washing bags in dishwasher, turn bags inside out and spread them over top rack of dishwasher, so entire surface is exposed to the washing water.
3. Dry thoroughly before reusing.

IMPORTANT: *To avoid possible illness, do not reuse bags after storing raw meats, raw fish or greasy foods. Do not reuse bags that have been microwaved or boiled.*

Storing Your Vacuum Sealer:

1. Keep the unit in a flat and safe place, out of the reach of children.
2. Remember to make sure the lid of the appliance is unlocked when not in use and in storage. Locking the cover will distort the foam gaskets causing leaking.

Storage Life Guide Continued

Foods	Where to store	Storage life when vacuumed sealed	Normal storage life
Meat			
Beef, Pork, Lamb	Freezer	2-3 years	6 months
Ground Meat	Freezer	1 year	4 months
Poultry	Freezer	2-3 years	6 months
Fish	Freezer	2 years	6 months
Hard Cheeses			
Cheddar, Swiss	Refrigerator	4-8 months	1-2 weeks
Parmesan	Refrigerator	4-8 months	1-2 weeks
Vegetables (Most vegetables need to be blanched before vacuum sealing)			
Asparagus	Freezer	2-3 years	8 months
Broccoli, Cauliflower	Freezer	2-3 years	8 months
Cabbage, Brussels Sprouts	Freezer	2-3 years	8 months
Corn (cob or kernel)	Freezer	2-3 years	8 months
Green Beans	Freezer	2-3 years	8 months
Lettuce, Spinach	Refrigerator	2 weeks	3-6 days
Snow Peas, Snap Peas	Freezer	2-3 years	8 months
Fruits			
Apricots, Plums	Freezer	1-3 years	6-12 months
Peaches, Nectarines	Freezer	1-3 years	6-12 months
Softer Berries			
Raspberries, Blackberries	Refrigerator	1 week	1-3 days
Strawberries	Refrigerator	1 week	1-3 days
Harder Berries			
Blueberries	Refrigerator	2 weeks	3-6 days
Cranberries	Refrigerator	2 weeks	3-6 days

Storage Life Guide Continued

Foods	Where to store	Storage life when Vacuumed sealed	Normal storage life
Baked Goods			
Bagels, Bread, Pastries	Freezer	1-3 years	6-12 months
Nuts			
Almonds, Peanuts	Pantry	2 years	6 months
Sunflower Seeds	Pantry	2 years	6 months
Coffee			
Coffee Beans	Freezer	2-3 years	6 months
Coffee Beans	Pantry	1 year	3 months
Ground Coffee	Freezer	2 years	6 months
Ground Coffee	Pantry	5-6 months	
Prepared Liquids			
Sauces, Soups, Stews	Freezer	1-2 years	3-6 months
Dry Foods			
Beans, Grains	Pantry	1-2 years	6 months
Pasta, Rice	Pantry	1-2 years	6 months
Powdery Foods			
Dry Milk	Pantry	1-2 years	6 months
Dried Coconut	Pantry	1-2 years	6 months
Flour	Pantry	1-2 years	6 months
Sugar, Brown Sugar	Pantry	1-2 years	6 months
Snack Foods			
Chips	Pantry	3-6 weeks	1-2 weeks
Cookies, Crackers	Pantry	3-6 weeks	1-2 weeks

1 Year Warranty

The complete Luvele range of products is backed by our 1 Year Total Cover Warranty. Our warranty will covers any manufacturing fault with the product and will also cover damage caused during transit.

Your warranty starts from the purchase date of your Luvele product.

You do not need to register your warranty as your details are automatically processed at the time of purchase.

Warranty Process

We want to make any warranty claim as simple as possible for you. All you need to do is contact us at **support@luvele.com** and provide us information about the problem you are having with your item. Firstly, we will suggest some troubleshooting ideas to establish whether or not the issue can be fixed without a return. Photos of the fault may be requested if and where appropriate, and if it will ensure a faster resolution.

Generally, if you have an issue with your item within 30 days of receiving it, we will email you a prepaid return label that can be printed out and used to send the item back with. We will then generally send you a brand new item. The new item will be shipped within 48 hours of receiving the faulty item back. A confirmation email will be send when your faulty item is received back.

If you have an issue after the 30 day period we will consider repairing your item if suitable. If it cannot be repaired it will be replaced with a brand new item. Refunds will only be offered within the 30 day money back guarantee, if you choose this option over a new replacement. Outside of this 30 day period, your item will be repaired or replaced.

We are here to help, so please email us and the best solution to meet your needs will be offered.

support@luvele.com



www.luvele.com