

WHAT YOU WILL NEED:



Ruler



Pencil

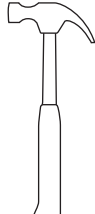

Hammer

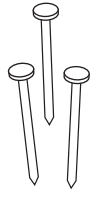

3 Nails
(provided)

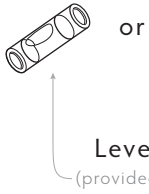

Level
(provided)

HOW TO HANG YOUR MAP

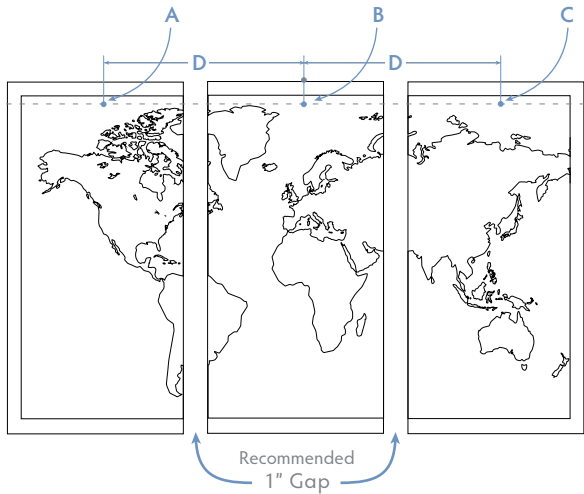

To hang your map, you will need to find points **A**, **B**, and **C** on your wall.

On **48" X 32"** maps the distance between these points (**Distance D**) is **17"** (or **16" + Desired Gap**)

On **54" X 36"** maps the distance between these points (**Distance D**) is **19"** (or **18" + Desired Gap**)

1: Hold the center panel of the map against the wall in your desired location.



2: With the map held firmly in place, lightly make a mark on the wall with your pencil in the center of the map.

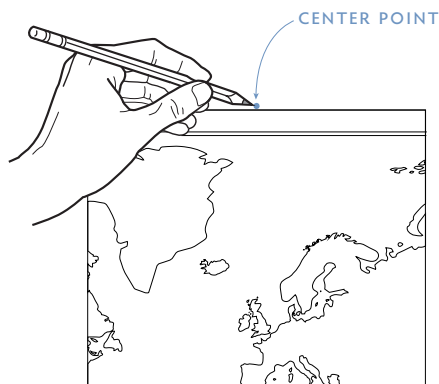

3: Measure **1/2"** straight down from the center point that was made in step 2 and make a new mark (we'll call that point **B**).

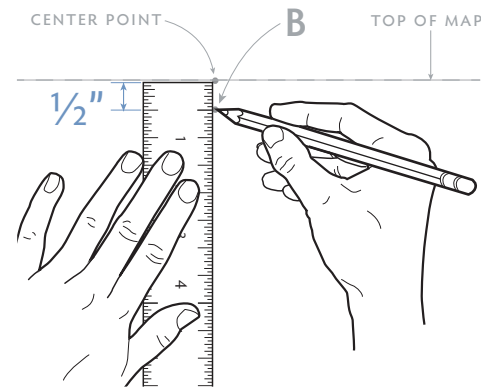

4: Using a level and a straight edge, measure **Distance D** straight over to the right of point **B** and make a new mark (we'll call that point **C**).

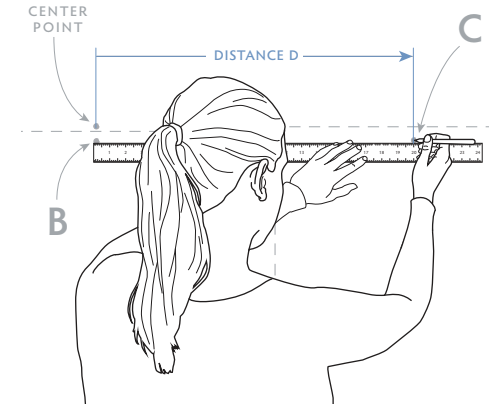

5: Measure **Distance D** straight over to the left of point **B** and make a new mark (we'll call that point **A**).

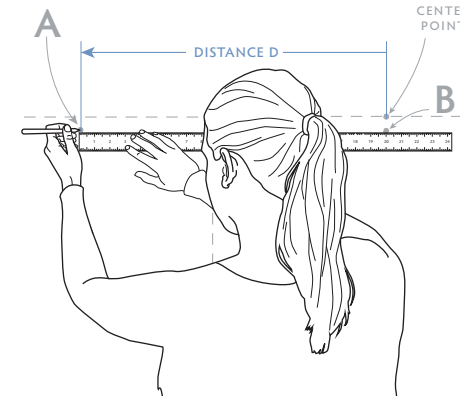

6: Confirm that points **A**, **B**, and **C** are all perfectly level with one another, then hammer the nails into those 3 points.

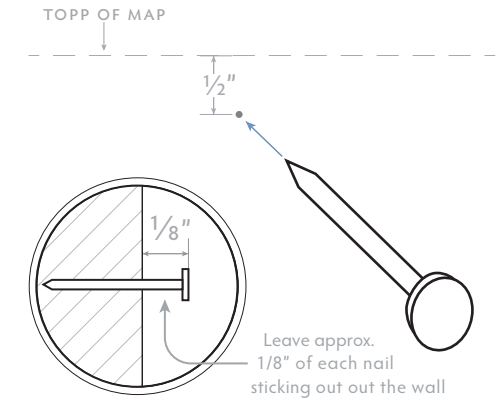

7: Erase/wipe off the pencil marks. Then hang your map panels on those nails and enjoy!

