

THIS DESIGN OR DRAWING IS NOT SOLID, BUT LENT AND IS SUBJECT TO RECALL. REPRODUCTIONS OF THIS DRAWING IN ANY MATERIAL FORM ARE RESERVED TO TRUSSFORTE BUILDING PRODUCTS PTY. LTD. UNDER COPYRIGHT LAW.

DO NOT SCALE

COMMERCIAL STOCK SIZES EXCEPTED AND UNLESS OTHERWISE NOTED, TOLERANCES AND DIMENSIONS ARE: METRIC

| SIZE TO | MACH. | CAST* |
|---------|-------|-------|
| 6 MM | ± 0.1 | ± 0.5 |
| 30 MM | ± 0.2 | ± 1.0 |
| 100 MM | ± 0.3 | ± 1.5 |
| 300 MM | ± 0.5 | ± 2.0 |
| 1000 MM | ± 0.6 | ± 3.0 |
| 2000 MM | ± 1.2 | ± 5.0 |

* INCLUDES STRUCTURAL STEEL WORK

REMOVE ALL BURRS AND SHARP EDGES BY 0.3x45° UNLESS OTHERWISE NOTED

SURFACE FINISH

| | Roughness Value | |
|--------|-----------------|-----------|
| | Met µmm | Grade No. |
| ROUGH | 50 | N12 |
| | 25 | N11 |
| | 12.5 | N10 |
| MED | 6.3 | N9 |
| | 3.2 | N8 |
| FINE | 1.6 | N7 |
| S.FINE | 0.8 | N6 |
| POLISH | 0.4 | N5 |
| | 0.2 | N4 |
| LAP | 0.1 | N3 |
| | 0.05 | N2 |
| | 0.025 | N1 |

ANGULARITY TOLERANCE < 0° 7'

CONCENTRICITY 0.1 MM

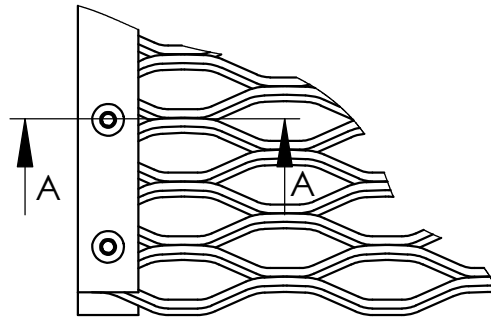

GRIDMESH CLAMPED BETWEEN CLAMP PLATE/FLAT AND SUPPORTING STRUCTURE

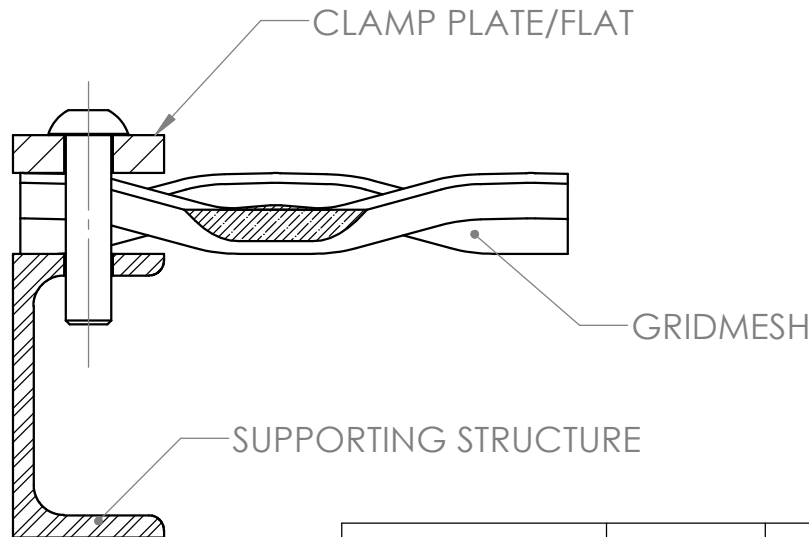
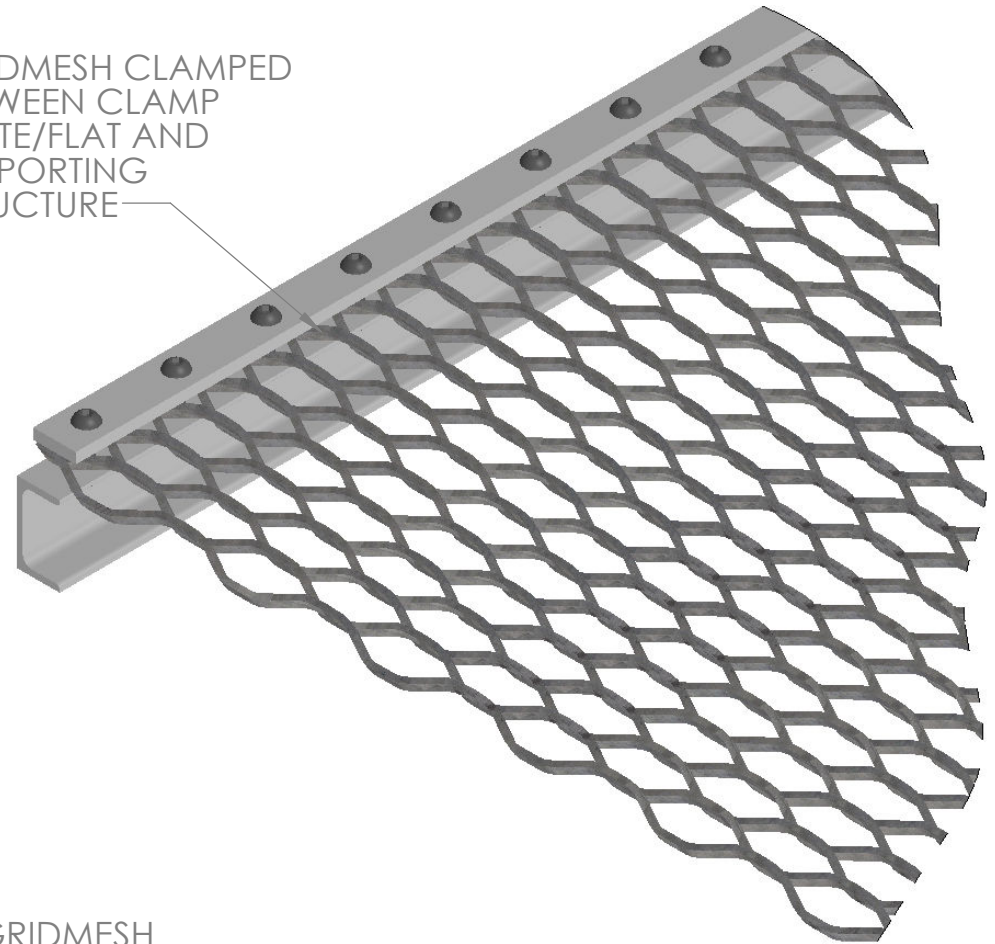

SECTION A-A
SCALE 1 : 2

| | | | |
|---------------------------|--------------|---|-----------------|
| DIMENSIONS IN MILLIMETERS | DO NOT SCALE | DRAWN M.G. | DATE 15/12/2015 |
| MATERIAL - | CHECKED - | SCALE 1:5 | |
| FINISH - | TITLE | DRAWING PRACTICE TO AS1100 - PROJECTION SYSTEM (UNLESS NOTED) | |
| | | | |
| | | GRIDMESH FIXING EXAMPLE 3 | |

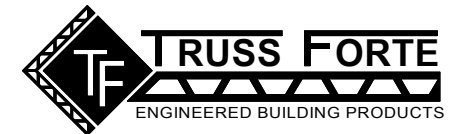

16 Gaine Road, Dandenong South, Vic. 3175. Ph 1300 362 813

| | |
|------------------|----------------------|
| DRG No. | REV. |
| GRIDFIX03 | - |
| SHEET 1 OF 1 | WEIGHT (KG) 51.50 A4 |