

# *Nidec*

92660US

## Model: KG-4

### JIGGER ARM **MANUAL**



For use with the VL-Whisper, RK-Whisper, RK-10, RK-2

(Please contact Shimpo to see if this will fit other RK models)

**Installation, Operation, Maintenance and Inspection Manual. Be sure to read this manual before operating the unit. Please use the Ball Mill Rack, correctly.**

Keep this manual for future reference.

日本電産シンポ株式会社

# 1. Parts / Specifications / Accessories

Part Names	Specifications
------------	----------------

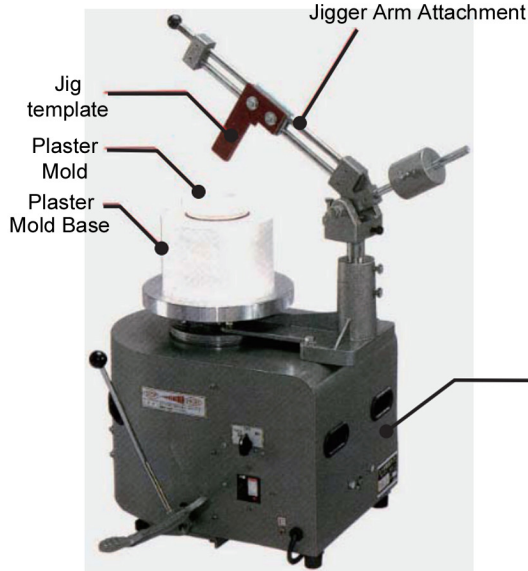

品番	Model: K G-4
Dimensions	680 x 210 x 495 ~ 590 mm, Height

SHIMPO Potter's Wheel (Can be used with Whisper models, RK-10 and RK-2 models)

Plaster molds and jig template are not included.

## Contents

### Jigger Arm Attachments

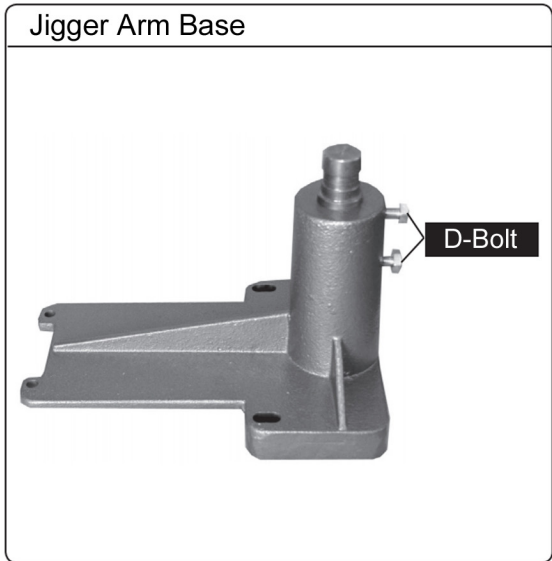
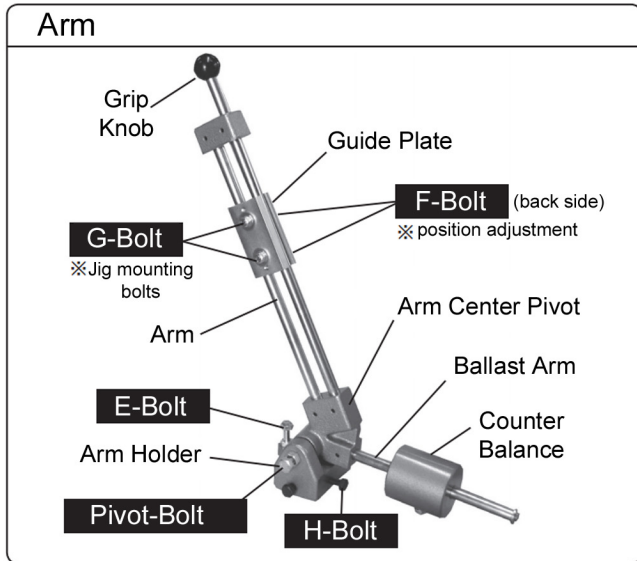

### Accessories

<p><b>T-Wrench</b></p> <p style="text-align: right;">Qty: 1</p>	<p><b>Spanner Wrenches</b></p> <p style="text-align: right;">Qty: 1 each</p>	<p><b>Hex Head Bolts</b></p> <p>Large bolts (M10 x 45)</p> <p>Small bolts (M8 x 45)</p> <p>Spring Washers</p> <p style="text-align: right;">Qty: 2 each</p>
---	--	---

## 2. Installation and Removal

### Installing the Jigger Arm

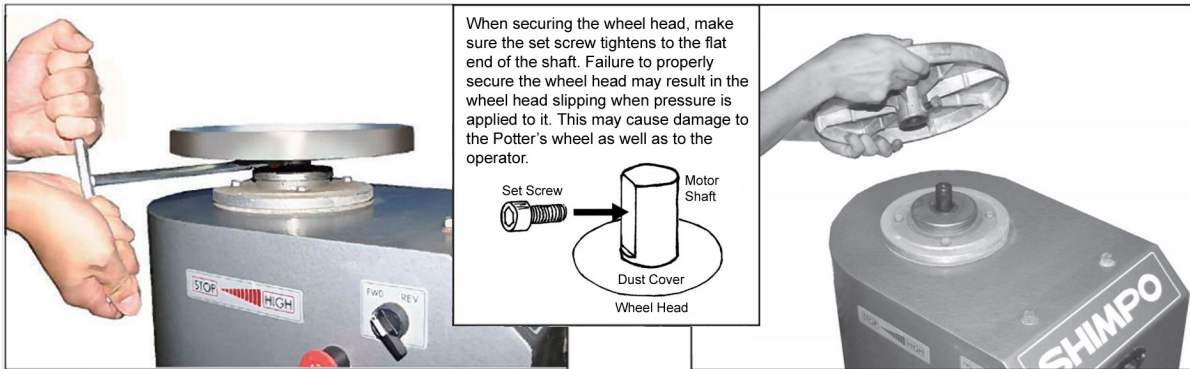

- 1 Remove the wheel head by loosening the set screw, using the T-Wrench. (turn the T-Wrench counter-clockwise to loosen and clockwise to tighten).

- 2 Remove the wheel head from the Potter's wheel by lifting straight up.

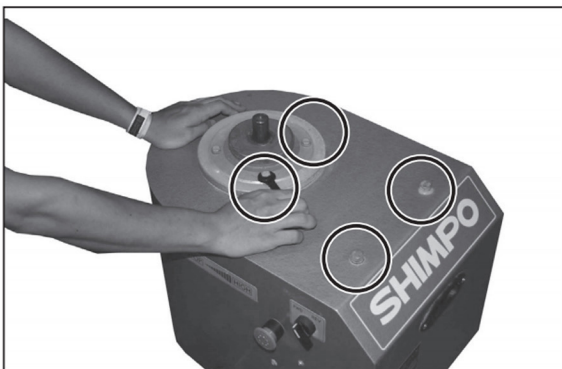

- 3 Remove both sets of bolts shown above, by using both large and small spanners.
- 4 Attach the Jigger Arm Base to the Potter's wheel, using the Hex Bolts provided.

When removing the bearing holder and wheel body bolts, make sure to store them in a safe place. These bolts will need to be re-installed should the Jigger Arm be dismantled.

- To mount the Jigger Arm Base to the Bearing Holder [A], use the small hex bolts

#### For Whisper Models:

For Whisper models, do not use the spring washers. Substitute sealed washers to attach [A] to the Potter's Wheel.

#### For RK-2 and RK-10 Models:

For older RK models, use the spring washers to attach [A] to the Potter's Wheel.

- To mount the Jigger Arm Base to the Potter's Wheel body [B], use the large hex bolts.

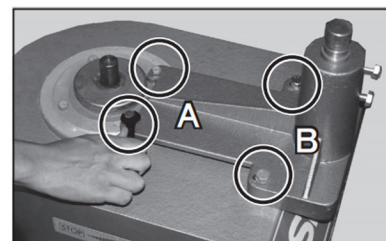
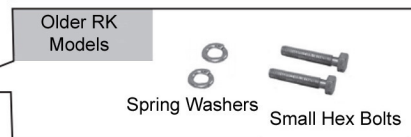
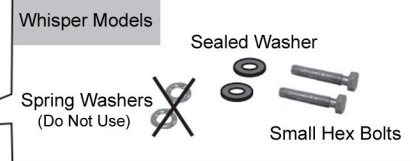
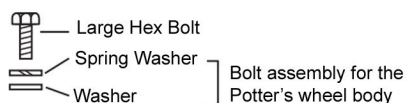

## 5 Attaching the Arm Holder

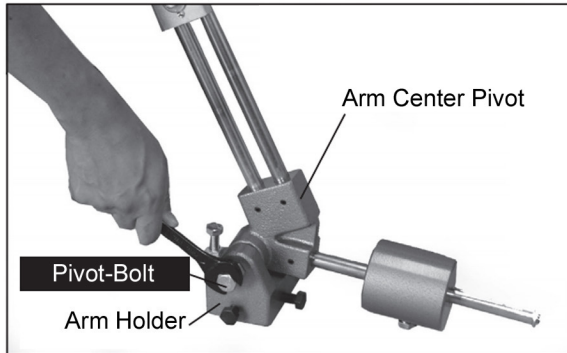

- ① Remove the pivot bolt on either side of the Arm Holder. Separate the Arm Holder from the Arm Center Pivot. (The Arm Center Pivot is heavy, take care when removing it from the Arm Holder.)

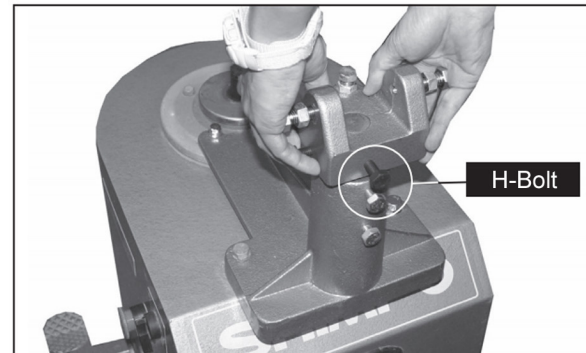

- ② Mount the Arm Holder on the Jigger Arm Base. Secure Arm Holder to the Jigger Arm Base by tightening the H bolt .

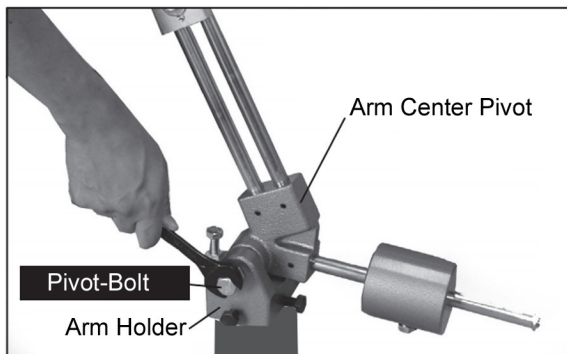

- ③ Place the Arm Center Pivot into the Arm Holder and secure it by tightening the Pivot-Bolts on both sides.

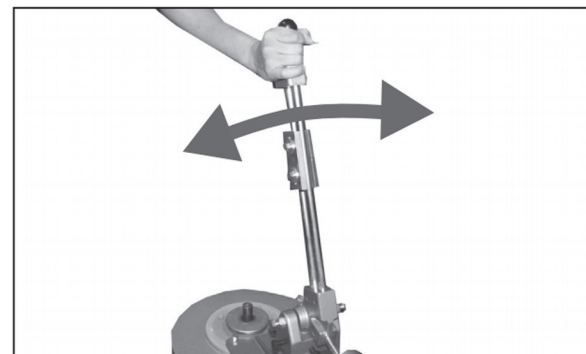

- ④ Shake the Arm to make sure there is no lateral movement of the Arm Center Pivot in the Arm Holder. If there is movement, tighten the Pivot-Bolts until there is no more lateral movement.

## Placing the Counter-Balance

Set the position of the Counter-Balance near the middle of the Ballast Arm.

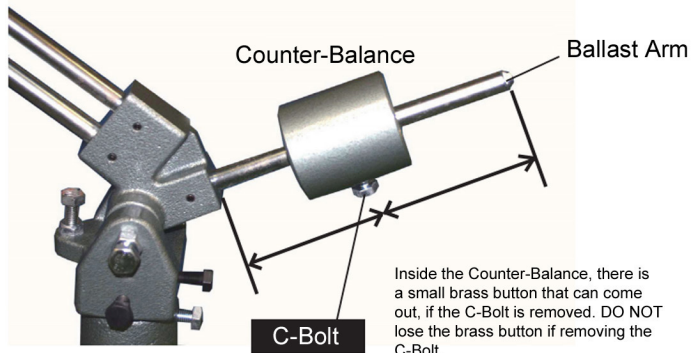

## Removing the Jigger Arm

Refer to page 2, section 2., Installation and Removal.

- 4** → **3** → **2** → **1** Remove the Jigger Arm in the reverse order in which it was installed.  
Next re-mount the wheel head.

### NOTE:

When securing the wheel head, make sure the set screw tightens to the flat end of the motor shaft. Failure to properly secure the wheel head may result in the wheel head slipping when pressure is applied to it. This may cause damage to the Potter's wheel as well as to the operator.

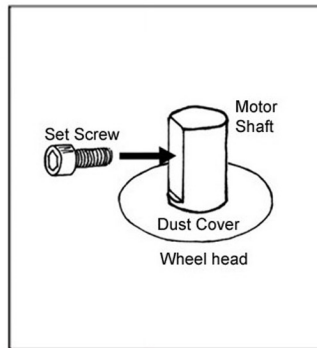

## 3. Proper Usage

### How to use the Jigger Arm

- 1** Pivot the Jigger Arm in its most upright position.
- 2** Add soft, workable clay to your mold.  
※ Have the wheel head turning in a counter-clockwise direction.
- 3** Lower the Arm in to the clay.
- 4** After producing the desired form, disengage the Arm and return it to its most upright position. Remove any excess clay from the mold.
- 5** Stop the wheel and remove the mold. Replace with a new mold and repeat steps 1-5, if desired.
- 6** After the piece has set for some time, remove it from the mold.

A **Nidec** Group Company

**SHIMPO** All for dreams

---

NIDEC-SHIMPO AMERICA CORPORATION • Itasca, IL 60143 USA • Phone: (800) 237-7079 • (630) 924-7138 • Fax: (630) 924-0340  
www.shimpoceramics.com • info@shimpoceramics.com