

**FINISHES**

**Leg Finish**

**Wood**



**Open-pore Matte Lacquered**



**Upholstery Finish**

**Fabric**



**Leather**

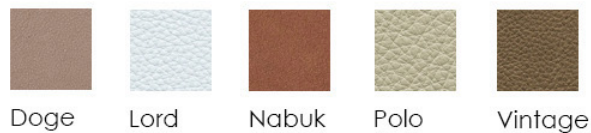

The broken lines and the vivid colors enrich the differences between the bases, which are light and steady. The signature feature is its seat: the shape, reminiscent of the cross-section of an egg, is designed to be comfortable and cocooning, in both the rigid lacquered version and the padded version with non-removable or loose covers, available in fabric, leather and synthetic leather.

**Synthetic Leather**



**Green Collection**

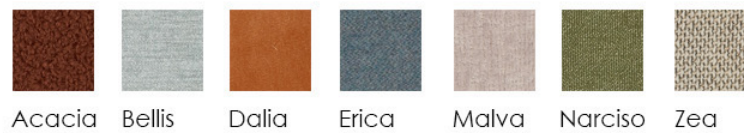

**Model 01183X / 01163**

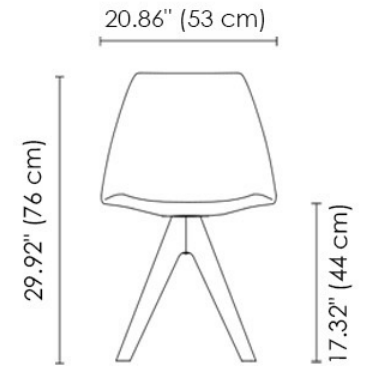

**MATERIALS**

- Polyurethane
- Wood
- Fabric
- Leather
- Synthetic Leather