

**PIANCA**

**FINISHES**

**Top Finish Marble**



Emperador Fior di Pesco Gioia di Carrara Grafite

**Wood**



Borgogna Canaletto Frassino Lino Frassino Miele Frassino Castano Frassino Antracite Frassino Nero

**Matte Lacquer**



Avio Bianco Bosco Cashmere Cenere Cipria Ecu Espresso Fango Lavagna Malva  
Mattone Miele Mirto Nebbia Nero Oceano Onice Piombo Roccia Seta Tabasco

**Central Pillar Finish**

**Concrete**



Roccia

**Matte Lacquer / High Gloss Lacquer**



Avio Bianco Bosco Cashmere Cenere Cipria Ecu Espresso Fango Lavagna Malva  
Mattone Miele Mirto Nebbia Nero Oceano Onice Piombo Roccia Seta Tabasco

**Base Finish Metal**



Bronzo Titanio Cromo Champagne Ottone Anticato

Sculptural, symbolic, bold: the table stem from a desire to have fun assembling three classic, primary, geometric elements in an ironic way. The central leg, monumental in size, tapers at the base to produce a lighter look and suggest an ironic contrast between the parts and an unexpected effect, fooling the eyes into believing it doesn't touch the ground. The effect is emphasized by the choice of materials.

**Terrazzo**



Arlecchino Balanzone Farinella Rugantino



**Model TOP7A / TOP7B**

W: 31.49"/39.37" (80/100 cm)

H: 29.52" (75 cm)

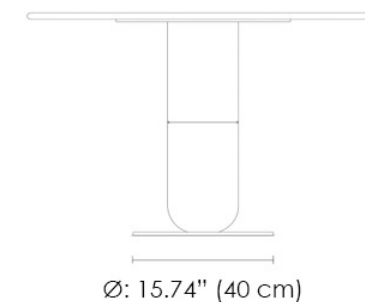

Ø: 15.74" (40 cm)

**DESIGN AWARD**



**MATERIALS**

- Metal (Base)
- Concrete (Pillar)
- Wood th - 0.86" (2.2 cm)
- Marble th - 0.78" (2 cm)
- Terrazzo th - 0.78" (2 cm)