

Misko S25 Suspended Lamp

Designer - Stone Designs

FINISHES

Disc Finish - Wood, Metal



Matte Black



Natural Walnut

Diffuser Finish - Glass



Matte White

Cable Finish - Fabric



Black

LIGHT SOURCES

LED: 10W (E26)
Fluo. max: 11W (E26)

CERTIFICATIONS



MATERIALS

- Metal
- Glass
- Wood
- Fabric

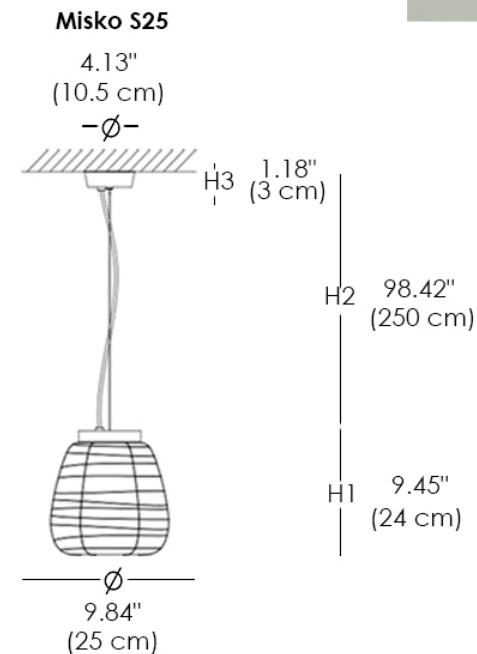

Japanese-inspired single or multiple suspension lamp, all of them created around a disc that houses the light source (E26). This is a UL Certified lamp.