

## Keshi S30 Suspended Lamp (Quick Ship)

Designer - David Abad

### FINISHES

Bar Finish - Metal



Matte Black

Lamp Finish - Marble



Black Markina

### LIGHT SOURCES

LED: 6W (E12)

Fluo. CFL max: 12W (E12)

Inc. max: 40W (E12)

Temperature: 2700k

CRI: ≥90

Voltage: 110V

### CERTIFICATIONS



### MATERIALS

- Metal
- Marble

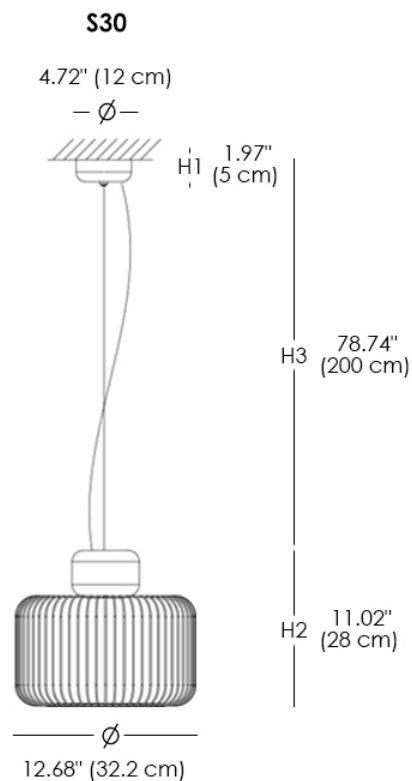
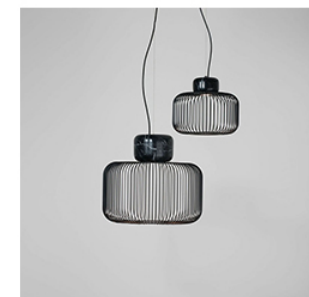

Suspension lamp crafted in sanded black Markina marble and metallic bar shade, finished in matte black. Upper metallic reflector with a mirror finish.

This is a UL Certified Lamp.