

C_Ball S2 Black Suspended Lamp (Quick Ship)

Designer - Stone Designs

FINISHES

Sphere Finish - Glass



Opal Glass

Structure Finish - Metal



Matte Black

LIGHT SOURCES

LED: 2 x 6W
Fluo. CFL max: 2 x 12W (E12)
Inc. max: 2 x 40W (E12)

CERTIFICATIONS



MATERIALS

- Metal
- Glass

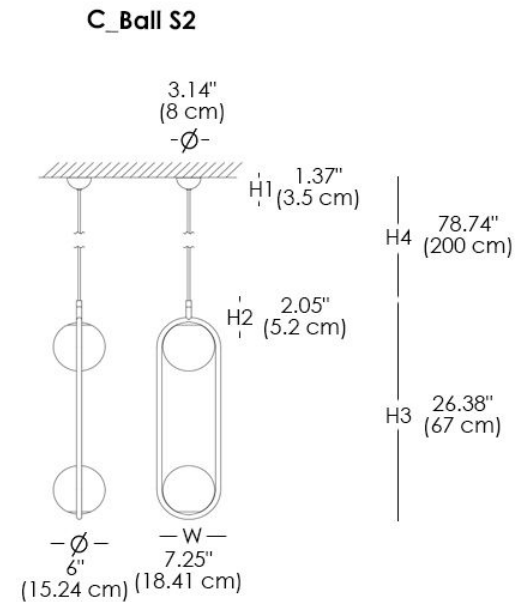

Suspension lamp consisting of two (S2) opal glass spheres. Its metal components are available in finish: matte black. This is a UL Certified lamp.