

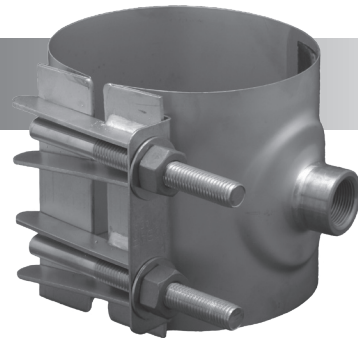

# 2606 SERIES

## INSTALLATION GUIDE



1. Visually inspect the Service Saddle to ensure it is the required nominal and outlet size for the desired application. Make sure that the saddle is complete and that there are no missing nuts, washers or lifter bar(s).
2. Open section (or sections) of saddle by backing off the nuts to end of the bolts. To avoid loss or misplacement of these components and to ease installation, do not completely remove nuts.
3. Clean the entire circumference of the pipe where the saddle is to be installed. Make sure to clean the threads with a wire brush. Galling WILL occur if there is sand or dirt on the threads, leaving the impression that the correct torque level has been reached. Lubricate the saddle gasket with a certified potable lube such as Robar's SLIKSTYX.
4. 2616 (Style 1) - Position the saddle on the pipe. Snap the lifter bar into position. Hand tighten the saddle onto the pipe. Be sure to avoid rotating the saddle once this has been done. Using a torque wrench, tighten the nuts incrementally to the specified torque value as marked on the saddle. Be sure to alternate between studs while tightening.

### TORQUE VALUES

All Sizes Boss-Pad Gasket: 65 ft-lbs.

5. 2626/2636 (Style 2 & 3) - Position the outlet section of the saddle on pipe. Snap the lifter bars into position and hand tighten the saddle onto the pipe. Be sure to avoid rotating the saddle once this has been done. Using a torque wrench, tighten the nuts incrementally and in a crossing pattern to the specified torque value marked on the saddle. Make every effort to maintain an equal distance between the saddle sections.

### TORQUE VALUES

All Sizes Boss-Pad Gasket: 65 ft-lbs.

6. Once torque has been achieved, inspect for proper fit and positioning. Install the main stop using Teflon tape. DO NOT over tighten the main stop as this will distort the outlet. Check for leaks. If leak occurs, remove saddle and re-install. Do not over tighten. If for any reason the gasket has been damaged, do not use.
7. Once the main stop has been installed into the saddle and the branch line has been successfully pressurized, DO NOT BEND or EXERT EXTERNAL PRESSURE on pipe leading to the saddle. Any slight distortion on the saddle shell (near outlet) is considered a bad installation. Be sure to re-tighten saddle to specified torque values after tapping operation and before backfilling.

## ROBAR INDUSTRIES LTD.

www.robarindustries.com  
waterworks@robarindustries.com

Surrey, British Columbia  
Phone: 1-800-663-6553

Saint-Bruno, Quebec  
Phone: 1-800-315-9525