

PROJECT : _____
SALE : _____

Lampitude

Product

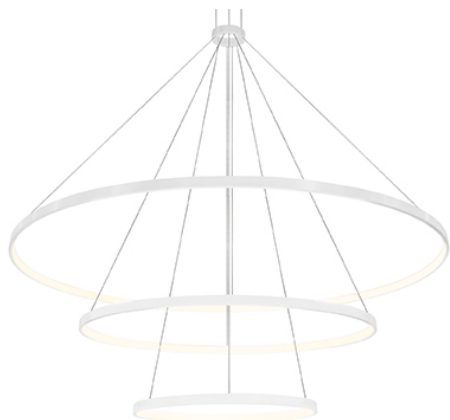

Dimension

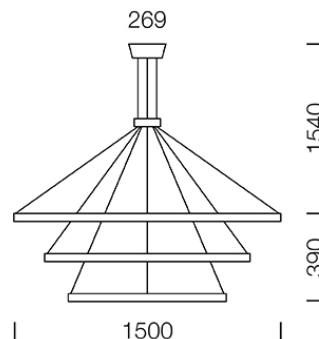

Specification

SERIES	: SATURN4
ITEM CODE	: SATURN4-L
DESCRIPTION	: HANGING LAMP
SIZE	: Ø1500 X H390+1540 (MM)
INSTALLATION	: SURFACE MOUNTED BASE
DRILL SIZE	: -
WEIGHT	: 5.4 KG
MATERIAL	: DIE-CAST ALUMINUM , ACRYLIC
COLOR	: WHITE
REFLECTOR	: -
DIFFUSER	: ACRYLIC
IP RATING	: 20
LIGHT SOURCES	: LED SMD 2216-3SDCM TUNABLE WHITE
SOCKET	: -
WATTS	: 120-150W
VOLT	: 24 V DC
CCT	: 2300-4000K
CRI	: 90
BEAM ANGLE	: -
LUMEN POWER	: -
LIFETIME	: -
CONTROL GEAR	: LED DRIVER INCLUDED
ACCESSORIES	: -
REMARKS	: -

Head office 299/1 (Ekamai) Klongton-Nua, Wattana, Bangkok Thailand 10110

Tel (02) 392 6371-5 FAX (02) 392 1839 Email info@lampitude.net www.lampitude.net