



**RECOMMENDED POWER SUPPLY**  
 12V OR 24V / 40W, DIN-RAIL, SLIM  
 MODEL: CF-MDR-40-12 OR CF-MDR-40-24

**Industrial RS-232/485 ⇔ 4x RS-485**  
**Opto-isolated Hub/Splitter/Repeater**  
 (Part Number: HUB-485-4)



[Http://www.CommFront.com](http://www.CommFront.com)

■ **INTRODUCTION**

The HUB-485-4 is a rugged, industrial-grade, optically-isolated RS-485 Hub / Splitter / Repeater, which can be used to expand RS-485 networks by splitting one RS-485 network into four, in turn increasing the maximum number of nodes and the distance covered by an RS-485 network. The unit comes with options for RS-485 or RS-232 input, for easy installation. It was designed so that data coming from the input (RS-232 or RS-485) will transmit data to all four loops of RS-485 networks. However, each loop of RS-485 devices will transmit data back to the input only, thus reducing any possible interference between each loop of the RS-485 devices. Also, the failure of any individual loop will not affect other loops, making the RS-485 networks more robust and reliable. The product features opto-isolation circuitry, which effectively protects your RS-232/RS-485 devices from ground loops, transient surges, remote lightning and spikes. Opto-isolation also eliminates ground loop and noise problems. The unit supports data rates up to 115,200 bps and features data format auto-sensing and self-adjusting; therefore, no DIP switch or jumpers are required.

■ **FEATURES**

- Industrial grade enclosed in a rugged, rustless ABS housing.
- Direct DIN-Rail or wall/panel mounting without using any unsecured brackets or adapters.
- Expands RS-485 networks by splitting one RS-485 network into four, thus making star-wiring possible for RS-485 networks.
- The failure of any individual loop will not affect the others, making the RS-485 network more robust and reliable.
- Optical isolation effectively protects RS-232/RS-485 devices from ground loops, transient surges, remote lightning and spikes; it also eliminates ground loop and noise problems.
- Supports up to 512 (4x 128) nodes of RS-485 devices.
- Supports data rates up to 115,200bps.
- Data direction auto-turnaround, no software drivers or flow control is required.
- Plug and play (hot-pluggable, data format auto-sensing and self-adjusting).
- Operating temperature: -40°F to 185°F (-40°C to 85°C).
- Built-in 600W surge protection, 15kV static protection and circuit protection.
- Surface Mount Technology manufactured to RoHS and ISO-9001 standards.
- Safety: Strictly certified by TUV (Cert No. SG-CE-100004; SG-FCC-100001).
- 5-year manufacturer's warranty.

■ **SPECIFICATIONS**

Compatibility:	EIA/TIA RS-232 and RS-485 standards
Power Source:	9 to 30VDC (External AC to DC power adapter included)
External AC/DC Power Adapter:	9VDC/500mA (Input: 100~240VAC 50/60Hz, US type A plug)
Current Consumption:	Less than 30mA
Optical Isolation:	2500Vrms (AC, 1 min)
Data Rates:	300 to 115,200bps (auto-sensing and self-adjusting)
Distances:	RS-232: 16ft (5m); RS-485: up to 4000ft (1.2km) at 19,200bps
Connectors:	2x 10-way Terminal Block
Number of Maximum Nodes:	Input: 1; Output: 4x 128 nodes;
Surge Protection:	600W
Static Protection (ESD):	Up to 15kV
Dimensions (H x W x D):	4.9 x 3.6 x 0.9 in (125 x 73 x 33 mm)
Weight:	4.9 oz (140 g) (with terminal blocks)
Operating Temperature:	-40°F to 185°F (-40°C to 85°C)
Operating Humidity:	Up to 90% RH (no condensation)

## PIN ASSIGNMENT

RS-232/RS-485 Input Side (Terminal Block):

Pin:	A+	B-	GND1	TX	RX	9~30V	GND1
RS-232:	-	-	Input/DC GND	TX	RX	DC +	Input/DC GND
RS-485:	485+	485-	Input/DC GND	-	-	DC +	Input/DC GND

4x RS-485 Output Side (Terminal Block):

Pin:	A1+	B1-	GND2	A2+	B2-	A3+	B3-	GND2	A4+	B4-
Output:	1			2		3			4	
RS-485:	485+	485-	Output GND	485+	485-	485+	485-	Output GND	485+	485-

## CONNECTIONS

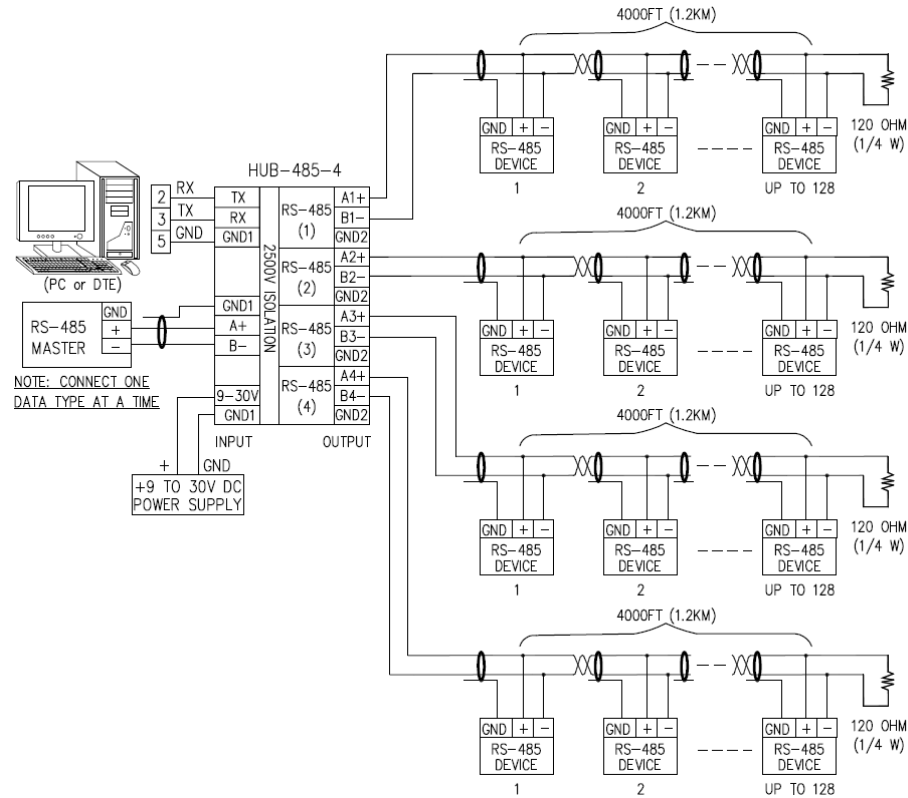

FIGURE 1: HUB-485-4 CONNECTION DIAGRAM

## LED INDICATIONS

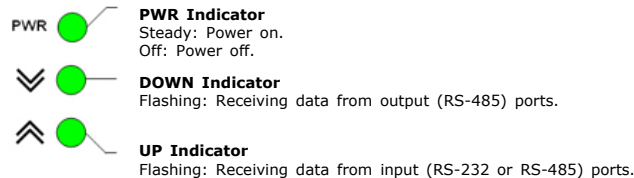

FIGURE 2: LED INDICATIONS

## INSTALLATIONS

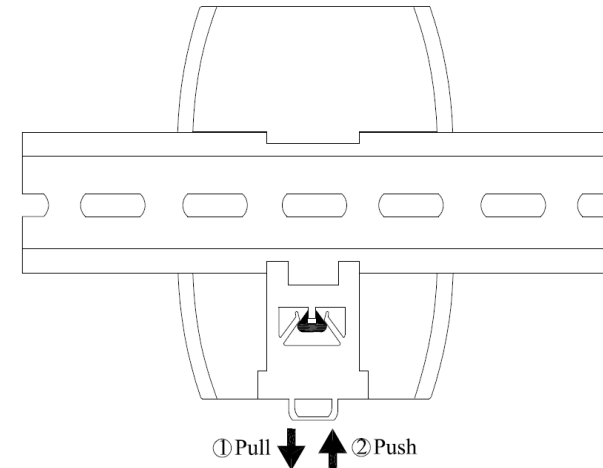

FIGURE 3: DIN-RAIL MOUNTING

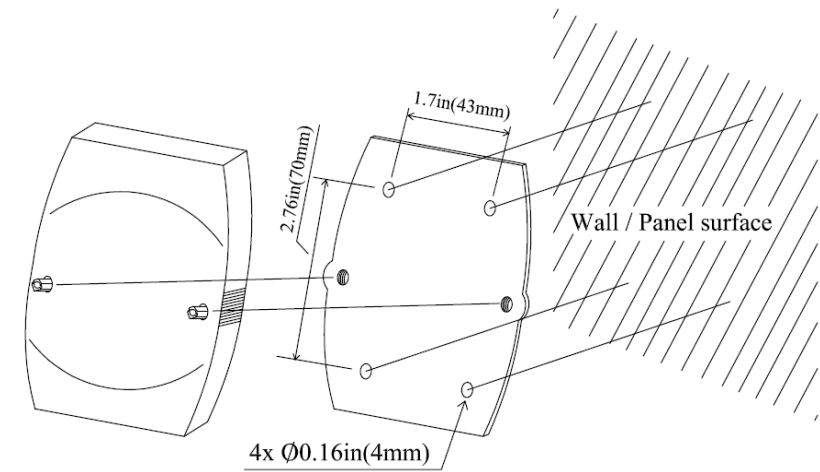
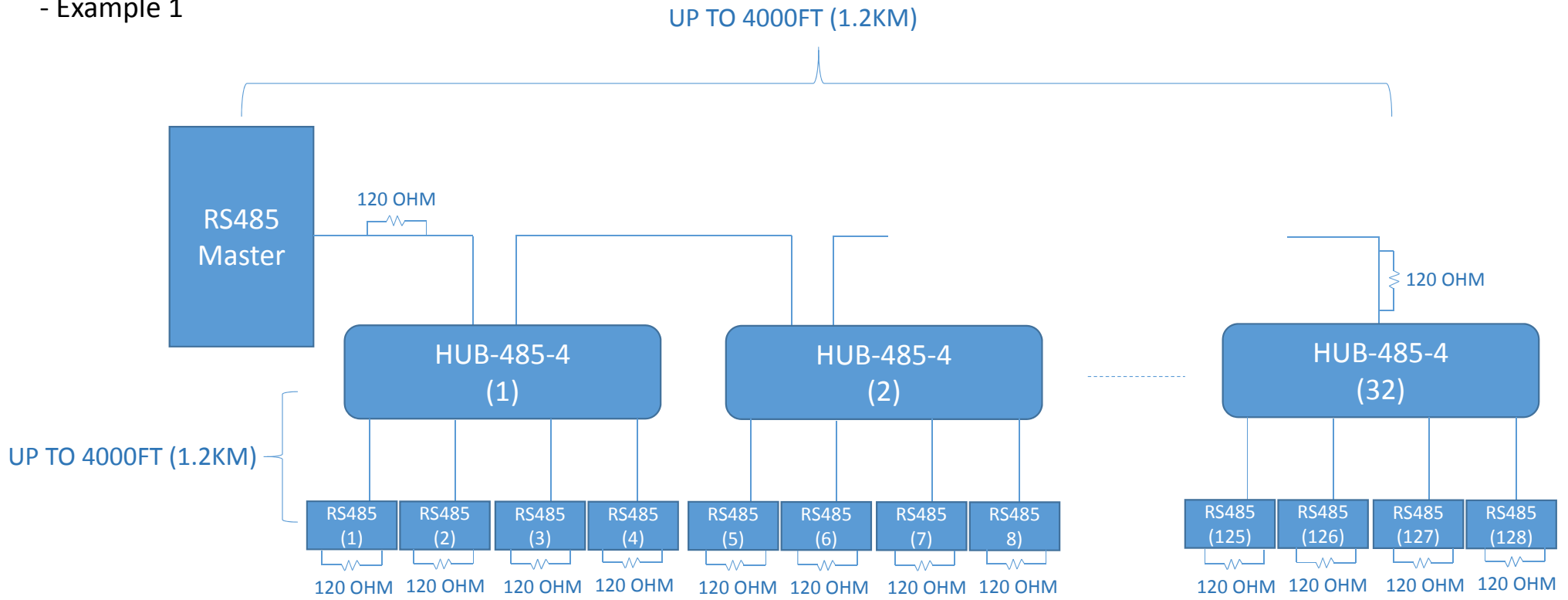

FIGURE 4: WALL/PANEL MOUNTING

## TROUBLESHOOTING

- Make sure the power is connected and turned on.
- Check the connections according to the above "CONNECTIONS" diagram.
- Perform a loopback test by using CommFront's 232Analyzer software: Connect one of your PC's RS-232 or RS-485 ports to the input of HUB-485-4. Now connect another RS-485 port from your PC to one of the HUB-485-4's RS-485 outputs. Send a command from one COM port, and you should receive an echo of the command sent on the other COM port. By performing a simple loopback test like this, you can test both the transmitter and receiver of the converter. This is very helpful when you are in doubt about the performance of your converter.

# Connecting Multiple HUB-485-4 - Example 1



Note: Connect 120-Ohm resistors at the end of the RS485 bus when the data rate is over 19.2Kbps or the distance of a single RS485 bus exceeds 660 feet or 200 meters.

# Connecting Multiple HUB-485-4 - Example 2

UP TO 4000FT (1.2KM)

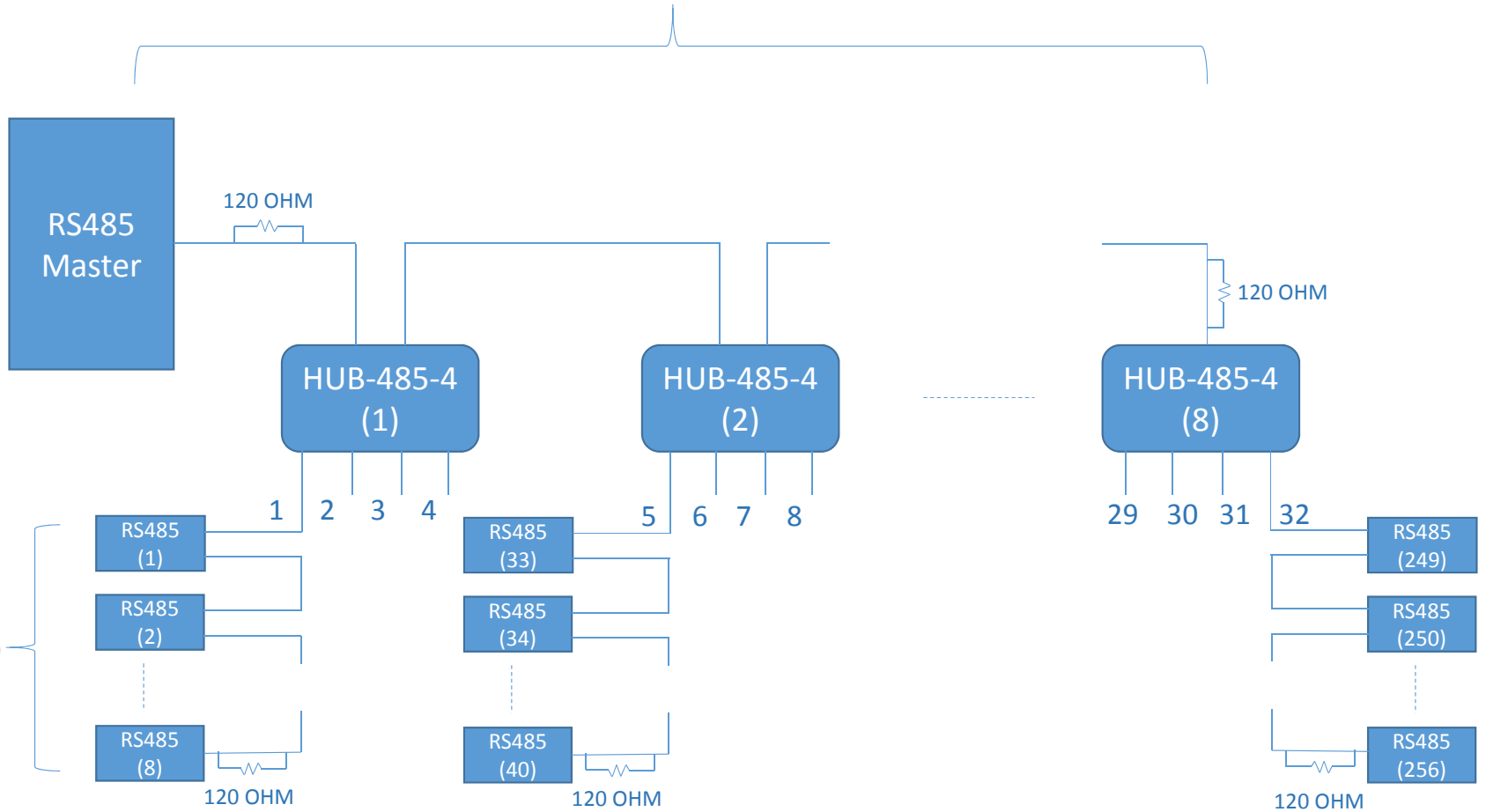

Note: Connect 120-Ohm resistors at the end of the RS485 bus when the data rate is over 19.2Kbps or the distance of a single RS485 bus exceeds 660 feet or 200 meters.