



Translation of the Original Operating Manual

For professional use.
Always follow the information in this manual,
particularly the safety instructions and the warning
instructions. Store the manual in a safe place.

Version 06/2018

GM 4700AC
GM 4700AC-H

**AirCoat Manual Gun for Flat
and Round Jet Nozzles**

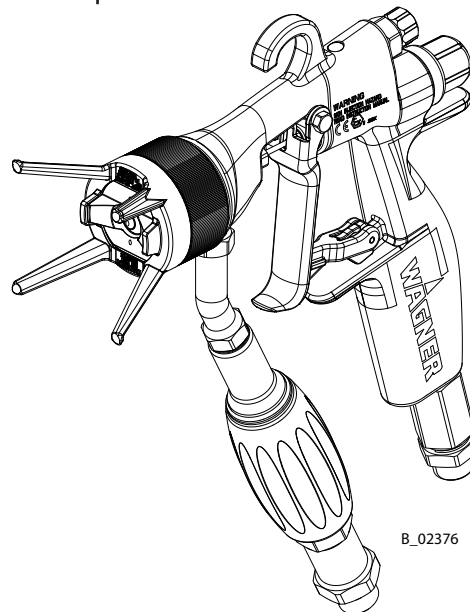

B_02376

Contents

1	ABOUT THESE INSTRUCTIONS	6
1.1	Preface	6
1.2	Warnings, Notices and Symbols in these Instructions	6
1.3	Languages	7
1.4	Abbreviations	7
1.5	Terminology for the Purpose of this Manual	7
2	CORRECT USE	8
2.1	Device Type	8
2.2	Type of Use	8
2.3	For Use in Potentially Explosive Areas	8
2.4	Processible Working Materials	8
2.5	Misuse	8
3	IDENTIFICATION	9
3.1	Explosion Protection Identification	9
3.2	Identification "X"	9
3.3	Type plate	10
4	BASIC SAFETY INSTRUCTIONS	11
4.1	Safety Instructions for the Operator	11
4.1.1	Electrical Devices and Equipment	11
4.1.2	A Safe Work Environment	11
4.1.3	Personnel Qualifications	12
4.2	Safety Instructions for the Personnel	12
4.2.1	Personal Safety Equipment	12
4.2.2	Safe Handling of WAGNER Spray Devices	13
4.2.3	Grounding the Unit	13
4.2.4	Product hoses	14
4.2.5	Cleaning and Flushing	15
4.2.6	Touching Hot Surfaces	15
4.2.7	Maintenance and Repair	16
4.2.8	Protective and Monitoring Equipment	16
5	DESCRIPTION	17
5.1	Components	17
5.2	Mode of Operation	17
5.3	Protective and Monitoring Equipment	17
5.4	Included Items	17
5.4.1	Version for application up to 25 MPa; 250 bar; 3625 psi	17
5.4.2	Standard equipment	17
5.5	Data	18
5.5.1	Materials of Paint-wetted Parts	18
5.5.2	Technical data	18
5.5.3	Dimensions and Connections	18
6	ASSEMBLY AND COMMISSIONING	19
6.1	Training of Assembly/Commissioning Personnel	19
6.2	Storage Conditions	19
6.3	Installation Conditions	19
6.4	Installation and Connection	20

6.4.1	Typical AirCoat spraying system	20
6.4.2	Ventilation of the Spray Booth	20
6.4.3	Air Supply Lines	21
6.4.4	Product supply lines	21
6.5	Grounding	21
6.6	Safety Checks	21
6.7	Lacquer Preparations	21
6.8	Commissioning	22
6.8.1	Procedure	22
6.8.2	Verifying a Safe Operational Condition	22
7	OPERATION	23
7.1	Training the Operating Personnel	23
7.2	Tasks	23
7.2.1	Starting to Spray with the AirCoat	23
7.2.2	Adjusting the Spray Pattern	24
7.3	Pressure Relief/Work Interruption	24
7.4	Changing AirCoat nozzle	25
7.4.1	Cleaning AirCoat nozzle	25
7.4.2	Eliminating Nozzle Clogging	26
8	CLEANING AND MAINTENANCE	27
8.1	Cleaning	27
8.1.1	Cleaning Personnel	27
8.1.2	Flushing and Cleaning the Spray Gun	27
8.2	Maintenance	28
8.2.1	Maintenance Personnel	28
8.2.2	Safety instructions	28
8.2.3	Safety Checks and Maintenance Intervals	29
8.2.4	Replacing the Product Hose or Air Hose	30
8.2.5	Changing or Cleaning Filter Insert	31
9	TROUBLESHOOTING AND RECTIFICATION	32
10	REPAIR WORK	33
10.1	Repair Personnel	33
10.2	Repair Notes	33
10.3	Tools	33
10.4	Replacing Parts on the Valve Rod	34
10.4.1	Replacing Valve Tappet Seals	35
10.4.2	Replacing the Rod Seal	35
10.4.3	Assembly	36
10.5	Replacing the Nozzle Seal	37
10.6	Replacing the "Air" Sealing Ring	37
10.7	Replacing the Sealing Fitting of the Round Jet Nozzle	38
10.8	Replacing the Spring Cap	38
10.9	Replacing the Filter Connection (only GM 4700AC)	39
10.9.1	Disassembly	39
10.9.2	Assembly	40

11	FUNCTION TEST AFTER REPAIR WORK	41
12	DISPOSAL	42
13	ACCESSORIES	43
13.1	Round jet nozzle attachment	43
13.1.1	Nozzle Inserts RXX	43
13.1.2	Nozzle screw joint, complete	43
13.2	Air caps	44
13.3	Anodized Union Nut	44
13.4	AirCoat Nozzles ACF3000	44
13.5	AirCoat Pre-atomizer Nozzles AC3000 Plus	45
13.6	Push-in Filter	45
13.7	Swivel joints	46
13.8	Hose Sets for GM 4700AC	46
13.9	Hose Sets for GM 4700AC-H	46
13.10	Nozzle Extensions	46
13.11	Miscellaneous	47
14	SPARE PARTS	49
14.1	How can spare parts be ordered?	49
14.2	Spare Parts List GM 4700AC	50
14.2.1	Assembly Aids GM 4700AC and GM 4700AC-H	52
14.3	Spare Parts List GM 4700AC-H	53
15	EU DECLARATION OF CONFORMITY	55

1 ABOUT THESE INSTRUCTIONS

1.1 PREFACE

The operating manual contains information about safely operating, maintaining, cleaning and repairing the device.

The operating manual is part of the device and must be available to the operating and service personnel.

The device may only be operated by trained personnel and in compliance with this operating manual.

Operating and service personnel should be instructed according to the safety instructions. This equipment can be dangerous if it is not operated according to the instructions in this operating manual.

1.2 WARNINGS, NOTICES AND SYMBOLS IN THESE INSTRUCTIONS

Warning instructions in this manual highlight particular dangers to users and to the device and state measures for avoiding the hazard. These warning instructions fall into the following categories:

 **DANGER** Immediate risk of danger.
Non-observance will result in death or serious injury.

 **WARNING** Potential risk.
Non-observance can result in death or serious injury.

 **CAUTION** Potentially hazardous situation.
Non-observance may result in minor injury.

 **NOTICE** Potentially hazardous situation.
Non-observance may result in damage to property.

Notice Provides information about particular characteristics and how to proceed.

Explanation of warning notice:

LEVEL OF DANGER

This notice warns you of a hazard!

Possible consequences of not observing the warning notice.

→ The measures for preventing the hazard and its consequences.



1.3 LANGUAGES

The operating manual is available in the following languages:

Original operating manual

Language	Order no.
German	2311729

Translation of the original operating manual

Language	Order no.	Language	Order no.
English	2311730	Danish	2369072
French	2311731	Dutch	2326027
Italian	2311732	Swedish	2391439
Spanish	2311733	Danish	2369072
Chinese	2328826	Finnish	2391441
Russian	2328825	Hungarian	2354518

Additional languages on request or at: www.wagner-group.com

1.4 ABBREVIATIONS

Order no.	Order number	Stk	Number of pieces
ET	Spare part	SW	Wrench size
K	Marking in the spare parts lists	GM	Manual gun
LA	Low Air	AC	AirCoat
HV	for high-viscosity products	H	Processing heated product (hot)
LV	for low-viscosity products	2K	2-component product
Pos	Position	DN	Nominal diameter

1.5 TERMINOLOGY FOR THE PURPOSE OF THIS MANUAL

Cleaning	
Cleaning	Manual cleaning of devices and device parts with cleaning agent.
Flushing	Internal flushing of paint-wetted parts with flushing agent.
Product pressure generator	Pump or pressure tank.
Personnel qualifications	
Trained person	Is instructed in the tasks assigned to him/her, the potential risks associated with improper behavior as well as the necessary protective devices and measures.
Electrically trained person	Is instructed by an electrician about the tasks assigned to him/her, the potential risks associated with improper behavior as well as the necessary protective devices and measures.
Electrician	Can assess the work assigned to him/her and detect possible hazards based on his/her technical training, knowledge and experience in relevant provisions.
Skilled person in accordance with TRBS 1203 (2010/Revision 2012)	A person, who, based on his/her technical training, experience and recent vocational experience, has sufficient technical knowledge in the areas of explosion protection, protection from pressure hazards and electric hazards (if applicable) and is familiar with the relevant and generally accepted rules of technology so that he/she can inspect and assess the status of devices and coating systems based on workplace safety.

2 CORRECT USE

2.1 DEVICE TYPE

Manual gun for manually coating work pieces.

GM 4700AC

GM 4700AC-H

2.2 TYPE OF USE

The automatic spray gun is suitable for atomizing liquid products, particularly coating products, using the AirCoat process.

- Non-ignitable products.
- Products in accordance with their classification in explosion class IIB.

WAGNER explicitly prohibits any other use!

The device may only be operated under the following conditions:

- Use the device only to work with the products recommended by WAGNER.
- Do not deactivate safety fixtures.
- Use only WAGNER original spare parts and accessories.
- The operating personnel must be trained on the basis of this operating manual.

2.3 FOR USE IN POTENTIALLY EXPLOSIVE AREAS

The device is suitable for use in potentially explosive areas as defined in Directive 2014/34/EU (ATEX), (see Explosion protection marking Chapter [3.1](#)).



2.4 PROCESSIBLE WORKING MATERIALS

Top-coat lacquers, primer paints, corrosion protection, textured lacquers, lyes, staining solvents, clear lacquers, separating agents, etc. with a solvent or water base. If you want to spray products other than the aforementioned, please contact a WAGNER representative.

Note:

Contact your local WAGNER dealer and the lacquer manufacturer if you encounter application problems.

2.5 MISUSE

Misuse can lead to physical injury and/or property damage!

Special attention must be paid that:



- no dry coating products, e.g. powder are processed;
 - no food, medicine or cosmetics are processed.
- It is important to note that the device's materials are not food-safe.

3 IDENTIFICATION

3.1 EXPLOSION PROTECTION IDENTIFICATION

As defined in the Directive 2014/34/EU (ATEX), the device is suitable for use in potentially explosive areas.

Device type: AirCoat manual gun GM 4700AC
 Manufacturer: Wagner International AG
 CH-9450 Altstätten, Switzerland

  II 2G X

CE	European Communities
Ex	Symbol for explosion protection
II	Device class II
2	Category 2 (zone 1)
G	Ex-atmosphere gas
X	Special notice



3.2 IDENTIFICATION "X"

The maximum surface temperature corresponds to the permissible product temperature. This and the permissible ambient temperature can be found in Chapter [5.5.2](#).

Safe Handling of WAGNER Spray Devices

Mechanical sparks can form if the device comes into contact with metal. In an explosive atmosphere:

- knocking or pushing metal against metal is to be avoided;
- do not drop the device.

Ignition temperature of the coating product

- Ensure that the ignition temperature of the coating product is above the maximum surface temperature.

Medium supporting atomizing

- To atomize the product, use only weakly oxidizing gases, e.g., air.

Cleaning

If there are deposits on the surfaces, the device may form electrostatic charges. Flames or sparks can form during discharge.

- Remove deposits from the surfaces to maintain conductivity.
- Use only a damp cloth to clean the device.

3.3 TYPE PLATE

- 1 Serial-No. XXXXX
- 2 Max. p air 0.8 MPa (115 psi)
- 3 Max. p fluid see tension nut
- 4 Max. T fluid 55°C (131°F)
Wagner International AG, Altstaetten
Made in Switzerland

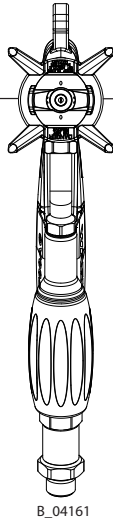

- 5 WARNING
 - 6 SKIN INJECTION HAZARD
READ INSTRUCTION MANUAL
- CE Ex II 2GX

B_04161

Pos	Designation
1	Serial number
2	Maximum air inlet pressure
3	Maximum product pressure see spring cap
4	Maximum product temperature (GM 4700AC = 55°C; GM 4700AC-H = 80°C - see Chapter 5.5.2)
5	Warning
6	Danger of injury from injection/read operating manual

4 BASIC SAFETY INSTRUCTIONS

4.1 SAFETY INSTRUCTIONS FOR THE OPERATOR

- Keep this operating manual at hand near the device at all times.
- Always follow local regulations concerning occupational safety and accident prevention.



4.1.1 ELECTRICAL DEVICES AND EQUIPMENT

Electric shock hazard!

Danger to life from electric shock

- Prepare device in accordance with the local safety requirements with regard to the operating mode and ambient influences.
- May only be maintained by skilled electricians or under their supervision. With open housings, the mains voltage poses a danger.
- Operate device in accordance with the safety regulations and electrotechnical regulations.
- Must be repaired immediately in the event of problems.
- Decommission if it poses a hazard or is damaged.
- Must be de-energized before work is commenced. Inform personnel about planned work. Observe electrical safety regulations.
- Ground all devices to a common grounding point.
- Only operate the device with a properly installed socket with a protective ground wire connection.
- Keep liquids away from electrical devices.



4.1.2 A SAFE WORK ENVIRONMENT

Hazard due to dangerous fluids or vapors!

Severe or fatal injuries due to explosion hazard or inhalation, swallowing or contact with the skin or eyes.

- Ensure that the floor in the working area is static dissipative in accordance with EN 61340-4-1 (resistance must not exceed 100 MΩ).
- Paint mist extraction systems/ventilation systems must be fitted on site according to local regulations.
- Make sure that the ground connection and potential equalization of all system parts are reliable and continuous and can withstand the expected stress (e.g. mechanical stress, corrosion).
- Ensure that product hoses / air hoses adapted to the working pressure are used.
- Ensure that personal protective equipment (see Chapter [4.2.1](#)) is available and is used.
- Ensure that all persons within the working area wear static dissipative shoes. Footwear must comply with EN 20344. The measured insulation resistance must not exceed 100 MΩ.
- Ensure that during spraying, persons wear electrically conductive gloves. The grounding takes place via the spray gun handle or the trigger.
- Protective clothing, including gloves, must comply with EN 1149-5. The measured insulation resistance must not exceed 100 MΩ.



- Ensure that there are no ignition sources such as naked flames, sparks, glowing wires, or hot surfaces in the vicinity. No smoking.
- Ensure that the pipe joints, hoses, equipment parts and connections are permanently, technically leak-proof:
 - Periodic preventative maintenance and service (replacing hoses, checking tightness strength of the connections etc.).
 - Regular monitoring of leaks and defects via visual inspection and odor testing, e.g., daily before commissioning, at the end of work or weekly.
- Ensure that maintenance and safety checks are performed regularly.
- In the event of defects, immediately bring the device or system to a stop and arrange to have repairs carried out immediately.

4.1.3 PERSONNEL QUALIFICATIONS

Hazard due to incorrect use of device!

Risk of death due to untrained personnel.

- Ensure that the operating personnel has been instructed by the operator in accordance with the operating manual and the operating instructions. The device must only be operated, maintained and repaired by trained personnel. Refer to the operating instructions for information about the required personnel qualifications.

4.2 SAFETY INSTRUCTIONS FOR THE PERSONNEL

- Always follow the information in this manual, particularly the safety instructions and the warning instructions.
- Always follow local regulations concerning occupational safety and accident prevention.



4.2.1 PERSONAL SAFETY EQUIPMENT

Hazard due to dangerous fluids or vapors!

Serious or fatal injuries due to inhalation, swallowing or contact with the skin or eyes.

- When preparing or working with lacquer and when cleaning the device, follow the working instructions of the manufacturer of the lacquers, solvents, and cleaning agents being used.
- Take the specified protective measures. In particular wear safety goggles, protective clothing and gloves, as well as hand protection cream if necessary.
- Use a mask or breathing apparatus if necessary.
- For sufficient health and environmental safety: Operate the device in a spray booth or on a spraying wall with the ventilation (extraction) switched on.
- Wear suitable protective clothing when working with hot products.



4.2.2 SAFE HANDLING OF WAGNER SPRAY DEVICES**Hazard due to injection of lacquer or flushing agent into the skin!**

The spray jet is under pressure and can cause dangerous injuries. Avoid injection of lacquer or flushing agents:

- Never point the spray gun at people.
- Never reach into the spray jet.
- Before any work on the device, in the event of work interruptions and malfunctions:
 - Switch off the energy/compressed air supply.
 - Relieve the pressure from the spray gun and device.
 - Secure the spray gun against actuation.
 - Disconnect the control unit from the mains.
 - In the event of functional faults: remedy the fault as described in the "Troubleshooting" chapter.
- If necessary or at least every 12 months, the liquid ejection devices must be checked for safe working conditions by an expert (e.g. WAGNER Service Technician) in accordance with the guidelines for liquid ejection devices (ZH 1/406 and DGUV 100-500 Chapters 2.29 and 2.36).
 - For shut down devices, the examination can be suspended until the next start-up.

**In the event of skin injuries caused by lacquer or flushing agents:**

- Note the lacquer or flushing agent that you have been using.
- Consult a doctor immediately.

Danger due to recoil forces!

Actuating the trigger can cause strong recoil forces. Thereby, the user can lose his balance and injure himself when falling.

Avoid risk of injury from recoil forces:

- Ensure that you have firm footing when operating the spray gun.

**4.2.3 GROUNDING THE UNIT****Hazard due to electrostatic charge!**

Explosion hazard and damage to the device.

Friction, flowing liquids and air or electrostatic coating processes create charges. Flames or sparks can form during discharge.

Correct grounding of the entire spraying system prevents electrostatic charges.

- Ensure that all devices and tanks are grounded before each spraying process.
- Ground the work pieces to be coated.
- Ensure that all persons inside the working area are grounded, e.g., that they are wearing static dissipative shoes.
- Wear static dissipative gloves when spraying. The grounding takes place via the spray gun handle or the trigger.



4.2.4 PRODUCT HOSES

Hazard due to bursting of product hose!

The product hose is under pressure and may cause dangerous injuries.

- Ensure that the hose material is chemically resistant to the sprayed products and the flushing agents used.
- Ensure that the product hose and the fittings are suitable for the pressure generated.
- Ensure that the following information can be seen on the high-pressure hose:
 - manufacturer,
 - permissible operating pressure,
 - date of manufacture.
- Make sure that the hoses are laid only in suitable places. Hoses should not be laid in the following places under any circumstances:
 - in high-traffic areas,
 - on sharp edges,
 - on moving parts or
 - on hot surfaces.
- Ensure that the hoses are never run over by vehicles (e.g., fork lift trucks), or that the hoses are never put under pressure from the outside in any other way.
- Ensure that the hoses are never kinked. Observe maximum bending radii.
- Ensure that no work is ever performed with a damaged hose.
- Make sure that the hoses are never used to pull or move the equipment.
- The electrical resistance of the product hose, measured at both valves, must be less than 1 MΩ.
- Suction hoses may not be subjected to pressure.

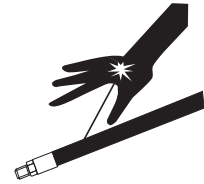

4.2.5 CLEANING AND FLUSHING

Hazard due to cleaning and flushing!

Explosion hazard and damage to the device.

- Preference should be given to non-ignitable cleaning and flushing agents.
- When carrying out cleaning work with flammable cleaning agents, make sure that all equipment and resources (e.g., collection tank, funnel, transport cart) are conductive or static dissipative and grounded.
- Observe the specifications of the lacquer manufacturer.
- Ensure that the flash point of the cleaning agent is at least 15 K above the ambient temperature or that cleaning is undertaken at a cleaning station with technical ventilation.
- Never use chloride or halogenated solvents (such as trichloroethane and methylene chloride) with units containing aluminium or galvanized and zinc-plated parts. They may react chemically thus producing an explosion danger.
- Take measures for workplace safety (see Chapter [4.1.2](#)).
- When commissioning or emptying the device, please note that:
 - depending upon the coating product used,
 - depending on the flushing agent (solvent) used.
 an explosive mixture may temporarily exist inside the lines and components of equipment.
- Only electrically conductive tanks may be used for cleaning and flushing agents.
- The tanks must be grounded.



An explosive gas/air mixture forms in closed tanks.

- Never spray into a closed tank when using solvents for flushing.

External Cleaning

When cleaning the exterior of the device or its parts, also observe the following:

- Relieve the pressure from the device.
- De-energize the device electrically.
- Disconnect the pneumatic supply line.
- Use only moistened cloths and brushes. Never use abrasive agents or hard objects and never spray cleaning agents with a gun. Cleaning the device must not damage it in any way.
- Ensure that no electric component is cleaned with or immersed into solvent.



4.2.6 TOUCHING HOT SURFACES

Hazard due to hot surfaces because of hot coating products!

Risk of burn injuries

- Only touch hot surfaces if you are wearing protective gloves.
- When operating the device with a coating product with a temperature of > 43 °C; 109 °F:
 - Identify the device with a warning label "Warning - hot surface".

Order no.

9998910 instruction label

9998911 protection label

Note: Order the two stickers together.



4.2.7 MAINTENANCE AND REPAIR

Hazard due to improper maintenance and repair!

Danger to life and equipment damage.

- Only a WAGNER service center or a suitably trained person may carry out repairs and replace parts.
- Use only WAGNER original spare parts and accessories.
- Do not change or modify the device; if change is necessary, contact WAGNER.
- Only repair and replace parts that are listed in Chapter [13](#) and Chapter [14](#) that are assigned to the unit.
- Do not use any defective components.
- Before all work on the device and in the event of work interruptions:
 - Relieve the pressure from the spray gun, high-pressure hoses and all devices.
 - Secure the spray gun against actuation.
 - Switch off the energy and compressed air supply.
 - Disconnect the control unit from the mains.
- Observe the operating and service manual for all work.

4.2.8 PROTECTIVE AND MONITORING EQUIPMENT

Hazard due to removal of protective and monitoring equipment!

Danger to life and equipment damage.

- Protective and monitoring equipment must not be removed, modified or rendered unusable.
- Regularly check for perfect functioning.
- If defects are detected on protective and monitoring equipment, the system must not be operated until these defects are remedied.

5 DESCRIPTION

5.1 COMPONENTS

Pos	Designation
A	Suspension hook
B	Shaping air regulator
C	Spring cap
D	Trigger
E	Trigger locking device
F	Air connection
G	Fluid inlet
H	Union nut with nozzle protection
I	Nozzle / Air cap
J	Gun housing
K	Turning handle with filter housing

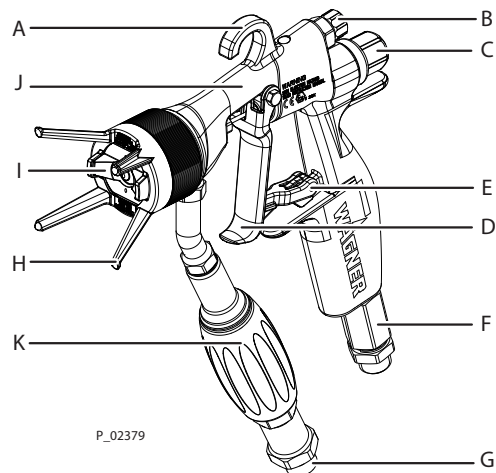

P_02379

5.2 MODE OF OPERATION

If the trigger (D) is operated when the trigger locking device (E) is released, then the air valve opens first. Atomizing air flows through the air connection (F) to the air cap (I). The product valve opens first if approx. 1/2 of the trigger's path is covered. The quantity of air for the atomization of the spray jet is preset via the external air automatic controller. The spray pattern can be adjusted using the shaping air regulator (B).

5.3 PROTECTIVE AND MONITORING EQUIPMENT

The spray gun is secured with the locking device (E) (the locking device turned in the spraying direction and fastened in the groove). The nozzle holder (H) has an anti-contact guard.

5.4 INCLUDED ITEMS

This AirCoat manual gun is available in two different versions. The choice of nozzle depends on the application, therefore this component is not included in the standard scope of delivery. A selection guide for spray gun accessories can be found in Chapter [13](#).

5.4.1 VERSION FOR APPLICATION UP TO 25 MPa; 250 BAR; 3625 PSI

Stk	Order no.	Designation
1	2313585	GM 4700AC 25 MPa, NPSM1/4" product connection
1	2315700	GM 4700AC-H 35 MPa, NPSM1/4" product connection (H = for processing heated product)

Please always order the nozzle separately.

5.4.2 STANDARD EQUIPMENT

Stk	Order no.	Designation
1	2316429	CE Declaration of Conformity
1	2311729	Operating manual, in German
1	see Chapter 1.3	Operating manual in local language
1	394335	Spring cap 16 MPa; 160 bar; 2320 psi

For special versions the delivery note applies.



5.5 DATA

5.5.1 MATERIALS OF PAINT-WETTED PARTS

Metals		Plastics	
Carbide	Stainless steel 1.4305	POM	FPM
Stainless steel 1.4301	Stainless steel 1.4104	PTFE	PA

5.5.2 TECHNICAL DATA

Description	Units	GM 4700AC	GM 4700AC-H
Maximum air inlet pressure	MPa; psi; bar	0.8; 120; 8	
Maximum product pressure *	MPa; psi; bar	25; 3625; 250 (16; 2320; 160*)	35; 5076; 350 (16; 2320; 160*)
Fluid inlet	inch	NPSM 1/4"	
Air connection	inch	G1/4"	
Filter **	Mesh	30, 50, 100, 150, 200	
Weight	g; oz	595 g; 20.9 oz	
pH range of the product	pH	3.5–9.0	
Maximum product temperature	°C; °F	55; 131	80; 176
Maximum air temperature	°C; °F	43; 109	
Sound level at 0.3 MPa; 3 bar; 43.5 psi air pressure and 11 MPa; 110 bar; 1549 psi product pressure***	dB(A)	< 82	

* Spring cap 16 MPa; 160 bar; 2320 psi is included

** For filter sizes, see Chapter 13.6.

*** A-rated sound pressure level measured at 0.5 m distance, Lpa 0.5 m, according to DIN EN 14462: 2005.

5.5.3 DIMENSIONS AND CONNECTIONS

Pos	mm	inch
A	173	6.81
B	216	8.50
C	48	1.89
D	152	5.98
E	39	1.54
F	--	NPSM 1/4"
G	--	G1/4"

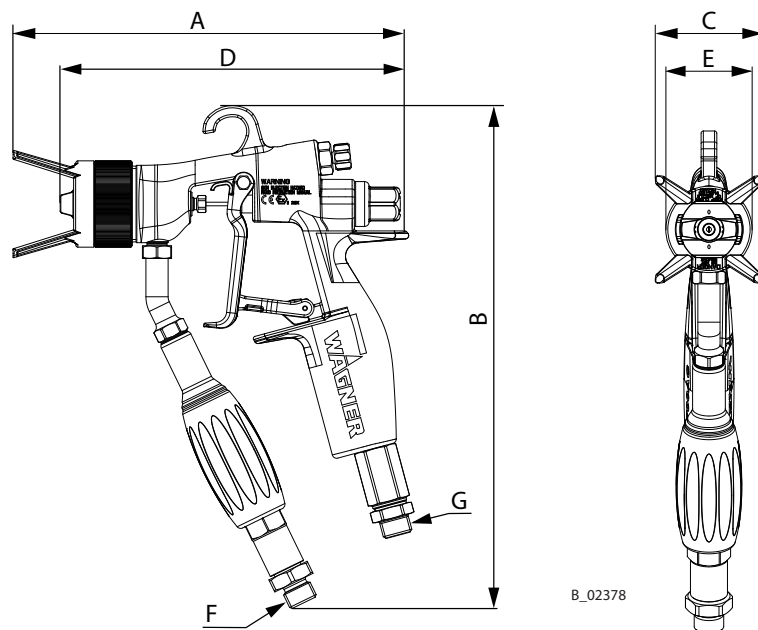

B_02378

6 ASSEMBLY AND COMMISSIONING

6.1 TRAINING OF ASSEMBLY/COMMISSIONING PERSONNEL

- The assembly and commissioning personnel must have the technical skills to safely commission the device.
- When assembling, commissioning and carrying out all work, read and follow the operating manuals and safety regulations for the additionally required system components.

A skilled person must check to ensure that the device is in a reliable state after it is installed and commissioned.

6.2 STORAGE CONDITIONS

Until the point of assembly, the device must be stored in a dry location, free from vibrations and with a minimum of dust. The device must be stored in closed rooms.

The air temperature at the storage location must be between -20 °C and 60 °C (-4 °F and 140 °F).

The relative air humidity at the storage location must be between 10 and 95% (without condensation).

6.3 INSTALLATION CONDITIONS

The air temperature at the installation site must be in a range between 0 °C and 40 °C (32 °F and 104 °F).

The relative air humidity at the installation site must be between 10 and 95% (without condensation).

6.4 INSTALLATION AND CONNECTION

The AirCoat manual gun GM 4700AC must be combined with various components to make up a spraying system. The system shown in the figure is only one example of an AirCoat spraying system. Your WAGNER distributor would be happy to assist you in creating a spraying system solution that meets your individual needs.

You must familiarize yourself with the operating manuals and the safety regulations of all additional system components before starting commissioning.

6.4.1 TYPICAL AIRCOAT SPRAYING SYSTEM

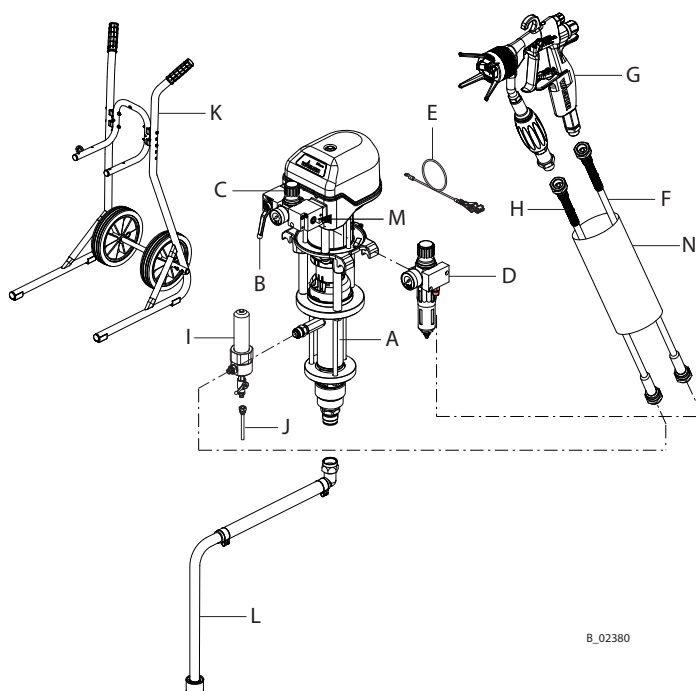

B_02380

Pos	Designation
A	Product pump
B	Compressed air shut-off valve
C	Pressure regulator
D	Air pressure regulator with air filter
E	Grounding cable
F	Air hose, electrically conductive
G	AirCoat spray gun

Pos	Designation
H	High pressure product hose
I	High-pressure filter/product pressure release
J	Return line
K	Pump mounting trolley
L	Suction system
M	Compressed air network
N	Protective hose

6.4.2 VENTILATION OF THE SPRAY BOOTH

- Operate the device in a spray booth approved for the working materials.
- or -
- Operate the device on an appropriate spraying wall with the ventilation (extraction) switched on.
- Observe national and local regulations for the exhaust air speed.

6.4.3 AIR SUPPLY LINES

Ensure that only dry, clean atomizing air is used in the spray gun! Dirt and moisture in the atomizing air worsens the spraying quality and spray pattern.

WARNING

Hose connections!

Risk of injury and damage to the device.

→ Do not mix up hose connections of product hose and air hose.



6.4.4 PRODUCT SUPPLY LINES

NOTICE

Impurities in the spraying system!

Spray gun blockage, products harden in the spraying system.

→ Flush the spray gun and paint supply with a suitable flushing agent.

DANGER

Bursting hose, bursting threaded joints!

Danger to life from injection of product.

→ Ensure that the hose material is chemically resistant to the sprayed products.

→ Ensure that the spray gun, fittings and product hose between the device and the spray gun are suitable for the pressure generated in the device.

→ Ensure that the following information can be seen on the high-pressure hose:

- manufacturer,
- permissible operating pressure,
- date of manufacture.



6.5 GROUNDING

WARNING

Heavy paint mist if grounding is insufficient!

Danger of poisoning.

Insufficient paint application quality.

→ Ground all device components.

→ Ground the work pieces to be coated.



A conductive connection (potential equalization cable) must be established between original tank and the equipment.

6.6 SAFETY CHECKS

→ Carry out safety checks in accordance with Chapter [8.2.3](#).

6.7 LACQUER PREPARATIONS

The viscosity of the lacquer is of great importance. The best spraying results are obtained with values between 80 and 260 millipascals (mPas) × sec.

Please also read the technical data sheet of the lacquer for optimal processing, viscosity adjustment and intermixing of the product.

6.8 COMMISSIONING**⚠ NOTICE****Impurities in the spraying system!**

Spray gun blockage.

→ Flush the spray gun and paint supply with a suitable flushing agent before commissioning.

6.8.1 PROCEDURE

1. Secure the spray gun.
2. Connect the product hose to the spray gun and product supply system.
3. Connect air hose to spray gun and to oil-free, dry air supply.
4. For spray guns with filters, insert a suitable filter (filter insert, see Chapter [13.6](#)).
5. Fit nozzle on nozzle seal. Fit air cap over nozzle.

Note the flattened parts (X) on the nozzle and in the air cap.

Fit the union nut with nozzle guard and tighten by hand.

6. Visually check the permissible pressures for all the system components.
7. Make sure that the device and all other conductive parts within the work area are grounded.
8. Set operating pressure at 100 bar; 10 MPa; 1450 psi and use a suitable medium to check that connections do not leak.

Note:

Pull the trigger and check whether the spray gun closes cleanly upon release.

9. Relieve the pressure of the spray gun and device and secure the spray gun.

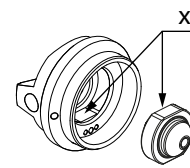

B_02261

6.8.2 VERIFYING A SAFE OPERATIONAL CONDITION

A skilled person must check to ensure that the device is in a reliable state after it is installed and commissioned.

This includes:

- Carry out safety checks in accordance with Chapter [8.2.3](#).



7 OPERATION

7.1 TRAINING THE OPERATING PERSONNEL

- The operating personnel must be qualified to operate the entire system.
- The operating personnel must be familiar with the potential risks associated with improper behavior as well as the necessary protective devices and measures.
- Before work commences, the operating personnel must receive appropriate system training.

7.2 TASKS

Ensure that:

- the regular safety checks are carried out in accordance with Chapter [8.2.3](#),
- commissioning is carried out in accordance with Chapter [6.8](#).

7.2.1 STARTING TO SPRAY WITH THE AIRCOAT

1. Start up with product supply set to approx. 8 MPa; 80 bar; 1160 psi operating pressure.
2. Spray (release locking device and pull trigger) and at the same time, observe how the product is atomizing.
3. Set the spray pressure on the product pump to a point where good product atomization is achieved.
4. Open the air pressure regulator for the atomizing air and adjust it so that an optimal atomization is achieved. (The interrelation between spray pattern and atomizing air is shown in the figure below).
5. Use the shaping air controller on the spray gun to adjust the shaping air to atomizing air ratio, until the optimal spray pattern is achieved.

Note:

Repeat points 3, 4 and 5 until the optimum is reached (iterative process).

Spray pattern shapes

No atomizing
air



Too little
atomizing air



Correct amount
of atomizing air

B_00071

Note:

The flow rate can be changed by:

- changing the product pressure or
- Using a different flat jet nozzle (see Chapter [7.4](#) and Chapter [13](#)).

7.2.2 ADJUSTING THE SPRAY PATTERN

The spray pattern can be adjusted to suit the object being sprayed using the shaping air regulator. The illustration shows the influence of the shaping air regulator on the spray pattern. Other nozzle sizes can be mainly used to obtain larger or smaller spray patterns.

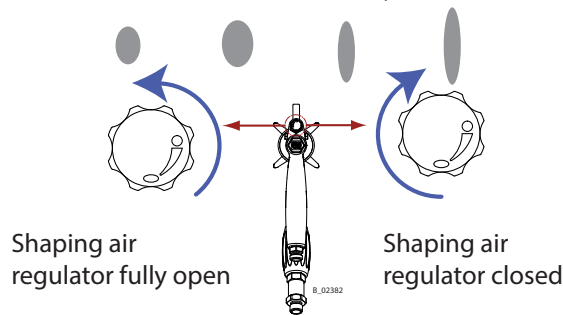

7.3 PRESSURE RELIEF/WORK INTERRUPTION

The pressure must always be relieved:

- after the spraying tasks are finished,
- before servicing or repairing the spraying system,
- before carrying out cleaning tasks on the spraying system,
- Before moving the spraying system to another location.
- before something must be checked on the spraying system,
- before the nozzle or the filter is removed from the spray gun.

The components for pressure relief on a CE-compliant spraying system include:

- Air cock with pressure relief hole mounted between compressed air source and pneumatic pump.
- Outlet equipment (return valve) mounted between pump and spray gun.

Pressure relief procedure

1. Close and secure the spray gun.
2. Relieve the air and product pressure in the product pressure generator in accordance with the respective operating manual.
3. Point the spray gun into the grounded metal tank for return product.
4. Release and open spray gun to relieve the pressure. Avoid splashback.
5. When no further overpressure is detected, close and secure the spray gun.
 - In the case of a clogged nozzle, proceed in accordance with Chapter [7.4.1](#).
 - If the product hose is obstructed: slowly loosen the hose connection to release the remaining pressure.

Note:

Always follow the procedure described above if pressure relief is specified in the operating manual.

If the spraying system has been used with 2K products:

⚠ NOTICE

Hardened product in the spraying system when 2K product is processed!

Destruction of pump and injection system.

- Observe the manufacturer's processing rules, particularly in regards to the pot life.
- Flush thoroughly before the end of the pot life.
- The pot life is decreased by warmth.

7.4 CHANGING AIRCOAT NOZZLE**⚠ NOTICE****Defective AirCoat nozzle!**

Insufficient paint application quality.

→ Do not use sharp-edged objects to treat carbide on the AirCoat nozzle.

1. Relieve the pressure on the spray gun and product pressure generator.
2. Secure the spray gun with the trigger locking device.
3. Unscrew union nut (A).
4. Remove air cap (B).
5. Press AirCoat nozzle (C) out of air cap (B) by hand and treat with cleaning agent until all remaining paint has been dissolved.

Assembly:

6. Fit AirCoat nozzle (C) in nozzle seal (D).
7. Fit air cap (B) over nozzle (C).
Note the flattened parts (X) on the nozzle and in the air cap.
8. Fit the union nut with nozzle guard (A) and tighten by hand.

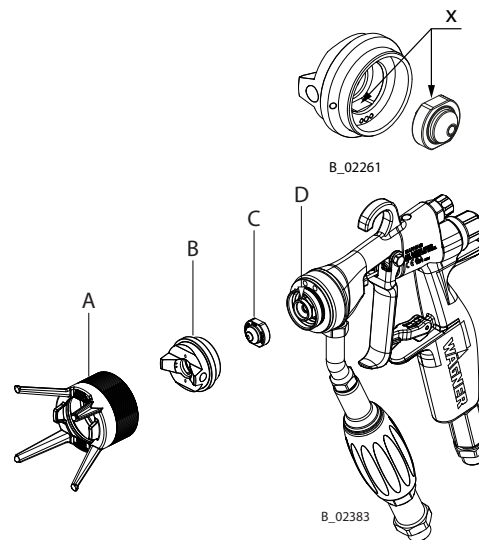
**7.4.1 CLEANING AIRCOAT NOZZLE**

For disassembly and assembly of AirCoat nozzles, see Chapter [7.4](#).

The AirCoat nozzle (C) can be placed into a cleaning solution which has been recommended by the paint manufacturer.

7.4.2 ELIMINATING NOZZLE CLOGGING

1. Relieve the pressure of the spray gun and device.
2. Secure the spray gun with the trigger locking device.
3. Unscrew the union nut with nozzle guard (A).
4. Remove air cap (B).
5. Push AirCoat nozzle (C) manually out of the air cap (B), reverse it and put it onto the nozzle seal (D) with nozzle tip facing towards the rear.
6. Refit air cap (B) on nozzle (C). Note the flattened parts (X) on the nozzle and in the air cap.
7. Screw the union nut with nozzle guard (A) over the air cap (B) onto the spray gun and tighten by hand.
8. Switch the product pressure back on.
9. Turn the locking device to the spraying position and briefly pull trigger.
10. When the blockage has been flushed out, secure the spray gun with the trigger locking device.
11. Relieve the pressure of the spray gun and device.
12. Unscrew the union nut with nozzle guard (A).
13. Remove air cap (B) and push AirCoat nozzle (C) out by hand.
Clean the nozzle and put it back on nozzle seal (D) in the spray position.
14. Refit air cap (B) on nozzle (C). Note the flattened parts (X) on the nozzle and in the air cap.
15. Screw the union nut with nozzle guard (A) over the air cap (B) onto the spray gun and tighten by hand.
16. Switch the product pressure and the air pressure back on.

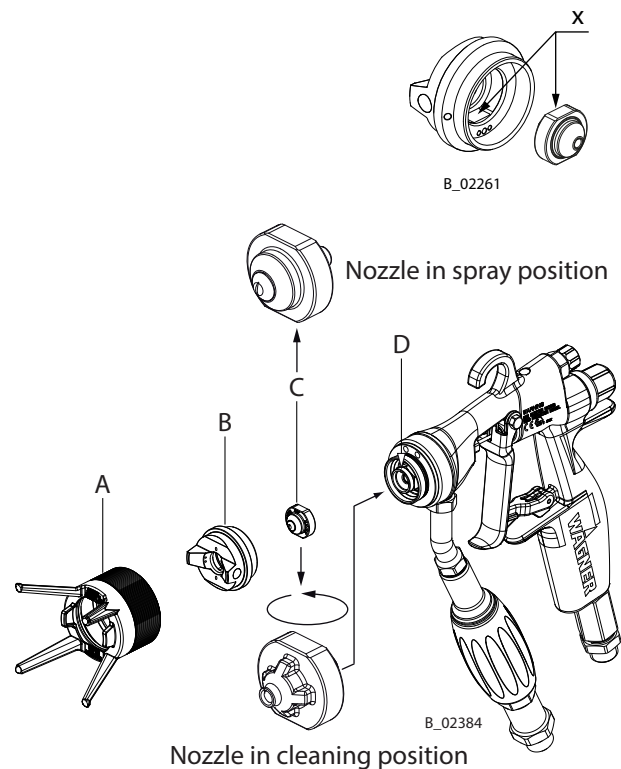

8 CLEANING AND MAINTENANCE

8.1 CLEANING

8.1.1 CLEANING PERSONNEL

Cleaning work should be undertaken regularly and carefully by qualified and trained personnel. They should be informed of specific hazards during their training.

The following hazards may arise during cleaning work:

- Health hazard from inhaling solvent vapors.
- Use of unsuitable cleaning tools and aids.

8.1.2 FLUSHING AND CLEANING THE SPRAY GUN

⚠ NOTICE

Flushing agent in the air duct!

Functional faults caused by swollen seals.

- Always point the spray gun down when cleaning.
- Ensure that neither paint nor flushing agent enters the air duct.
- Never immerse the spray gun in cleaning agent.

The spray gun and the device must be cleaned and flushed daily. The cleaning/flushing agents used for cleaning or flushing must correspond with the working material.

Note:

Methylene chloride is not recommended as an agent for flushing or cleaning the spray gun or other system components.

1. Visual check: personal safety equipment, grounding and all devices ready to use.
2. Relieve the pressure of the product pressure generator and of the spray gun in accordance with Chapter [7.3](#).
3. Secure the spray gun.
4. Dismount nozzle and clean separately (see Chapter [7.4](#) and [7.4.1](#)).
5. Supply product pressure generator with flushing agent according to the operating manual of the product pressure generator.
6. Set product pressure generator to a maximum product pressure of 4 MPa; 40 bar; 580 psi.
7. Flush product pressure generator in accordance with the respective operating manual.
8. Point the spray gun without nozzle into the grounded metal tank for return product.
9. Unlock the spray gun and rinse out thoroughly.
10. Cleaning or replacing the product filter in accordance with Chapter [8.2.5](#).
11. Repeat steps 7–10 if necessary.
12. Relieve the pressure of the product pressure generator and of the spray gun in accordance with Chapter [7.3](#).
13. Secure the spray gun.
14. Clean the gun body with a cleaning agent recommended by the lacquer manufacturer. Clean the trigger locking device area.
15. Dry with a cloth or a blow gun.
16. Dispose of the contents of the tank for return product according to the local regulations.

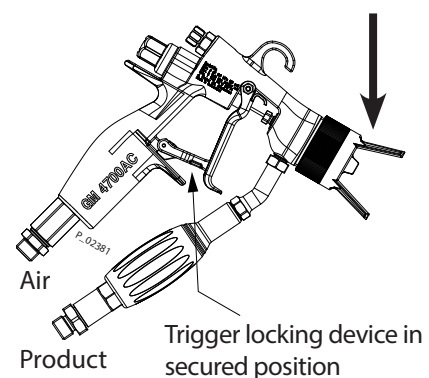

8.2 MAINTENANCE

8.2.1 MAINTENANCE PERSONNEL

Maintenance work should be undertaken regularly and carefully by qualified and trained personnel. They should be informed of specific hazards during their training.

The following hazards may arise during maintenance work:

- risk to health from inhaling solvent vapors,
- use of unsuitable tools and aids.

An authorized person must ensure that the device is checked for being in a reliable state after maintenance work is completed.

8.2.2 SAFETY INSTRUCTIONS

DANGER

Incorrect maintenance/repair!

Danger to life and equipment damage.

- Only a WAGNER service center or a suitably trained person may carry out repairs and replace parts.
- Use only WAGNER original spare parts and accessories.
- Only repair and replace parts that are listed in the "Spare parts" chapter and that are assigned to the unit.
- Before all work on the device and in the event of work interruptions:
 - Relieve the pressure from the spray gun, high-pressure hoses and all devices.
 - Secure the spray gun against actuation.
 - Switch off the energy and compressed air supply.
 - Disconnect the control unit from the mains.
- Observe the operating and service manual for all work.



Prior to Maintenance

- Flush and clean the system. → Chapter [8.1.2](#)
- Interrupt the air supply.

After maintenance

- Carry out safety checks in accordance with Chapter [8.2.3](#).
- Put the system into operation and check for leaks as described in Chapter [6.7](#).
- Have the system checked for safe condition by an authorized person.
- Function test in accordance with Chapter [11](#).

8.2.3 SAFETY CHECKS AND MAINTENANCE INTERVALS**Every day**

- Check grounding: see Chapter [6.5](#).
- Check hoses, tubes and couplings: see Chapter [8.2.4](#).
- Flush and clean the spray gun in accordance with Chapter [8.1.2](#).

Weekly

- Check spray guns for damage.
- Check that the safety fixtures function properly (see Chapter [5.3](#)).

Yearly or as required

- In accordance with DGUV regulation 100-500 Chapter 2.29 and 2.36:
 - The liquid ejection devices should be checked by an expert (e.g., WAGNER service technician) for their safe working conditions as required and at least every 12 months.
 - For shut down devices, the examination can be suspended until the next start-up.

8.2.3.1 PRODUCT HOSES, PIPES AND COUPLINGS

The service life of the complete hoses between product pressure generator and application device is reduced due to environmental influences even when handled correctly.

- Check hoses, pipes, and couplings every day and replace if necessary.
- Before every commissioning, check all connections for leaks.
- Additionally, the operator must regularly check the complete hoses for wear and tear as well as for damage at intervals that he/she has set. Records of these checks must be kept.
- The complete hose is to be replaced as soon as one of the two following intervals has been exceeded:
 - 6 years from the date of the hose crimping (see fitting embossing).
 - 10 years from the date of the hose imprinting.

Fitting embossing	Meaning
xxx bar	Pressure
yymm	Crimping date (year/month)
XX	Internal code

Hose imprinting	Meaning
Wagner	Name / Manufacturer
yymm	Date of manufacture (year/month)
xxx bar (xx MPa) e.g., 270 bar (27 MPa)	Pressure
XX	Internal code
DNxx (e.g., DN10)	Nominal diameter

8.2.4 REPLACING THE PRODUCT HOSE OR AIR HOSE

1. Flush and clean the spray gun in accordance with Chapter 8.1.2.
2. Relieve the pressure of the spray gun and device.
3. Secure the spray gun with the trigger locking device.

Product hose

4. Place the size A open-end wrench on the upper part of the product connection and hold it in place.
5. Unscrew the product hose nut using the size B open-end wrench.

Air hose

4. Place the size D open-end wrench on the upper part of the air connection and hold it in place.
5. Loosen the air hose's nut with a size C open-end wrench.

Assembly:

6. Screw on the product hose or air hose by hand and tighten with the two open-end wrenches.

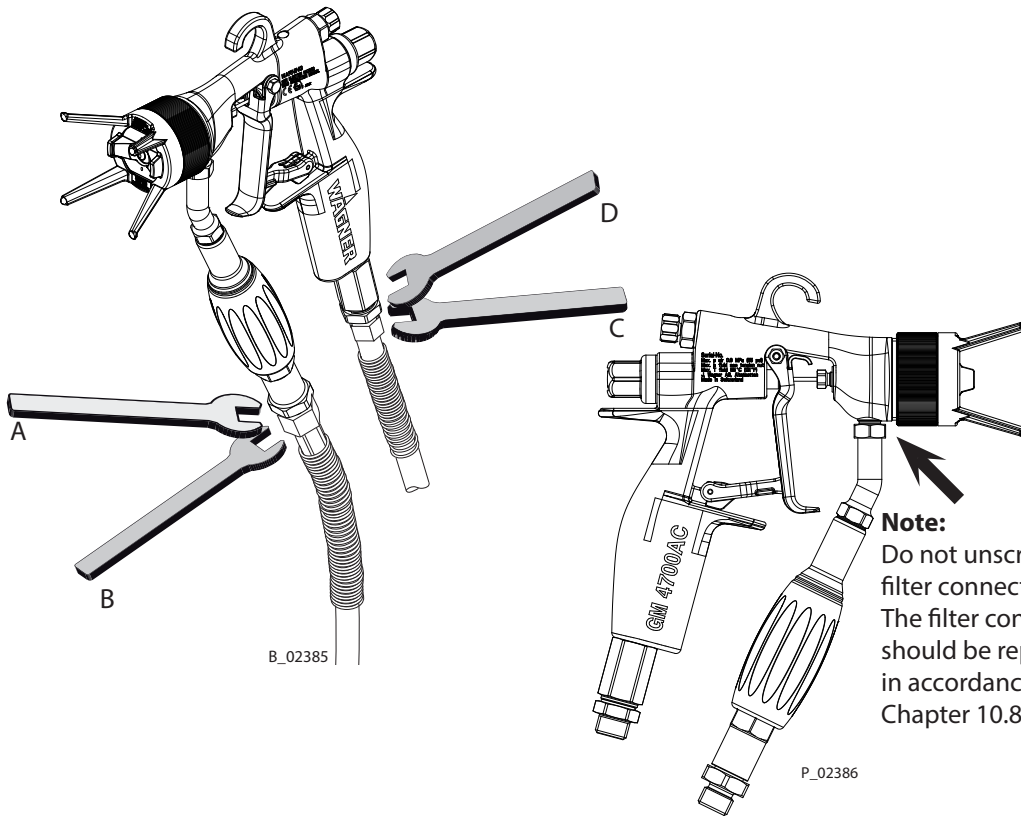

Description	Wrench A	Wrench B	Wrench C	Wrench D
GM 4700AC with NPS1/4" filter	19 mm 0.75 inch	19 mm 0.75 inch	17 mm 0.67 inch	17 mm 0.67 inch



8.2.5 CHANGING OR CLEANING FILTER INSERT

1. Flush and clean the spray gun in accordance with Chapter [8.1.2](#).
2. Relieve the pressure of the spray gun and device.
3. Secure the spray gun with the trigger locking device.
4. Loosen the filter housing (67) manually with turning handle (66) and unscrew it. When the product hose together with filter housing and filter insert has been exposed, push the turning handle (66) back onto the upper filter connection.
5. Pull the filter insert (64) out of the filter housing (67).
6. Thoroughly clean all parts with flushing agent.

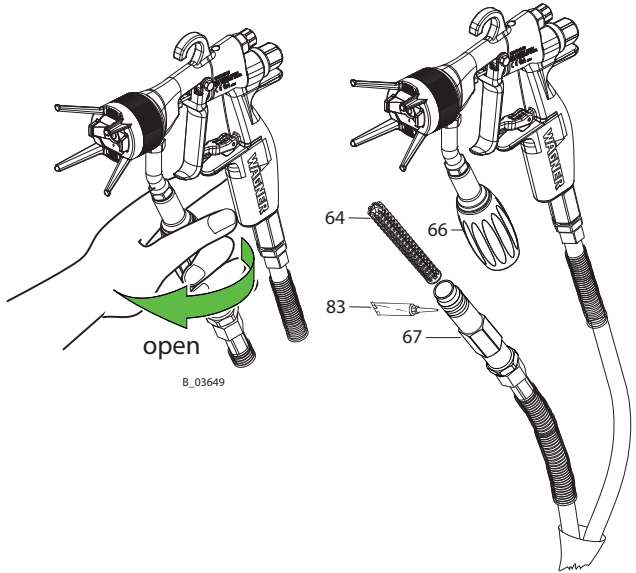

Assembly:

7. Push the cleaned or new filter insert (64) with opening downwards into the filter housing (67).
8. Insert the filter housing (67) into the turning handle, screw in manually with the turning handle and tighten.

Procedure if connection is difficult to loosen:

Loosen filter housing (67) with wrench size B open-end wrench, supporting the filter connection with size A open-end wrench.

Wrench A	Wrench B
13 mm 0.51 inch	17 mm 0.67 inch

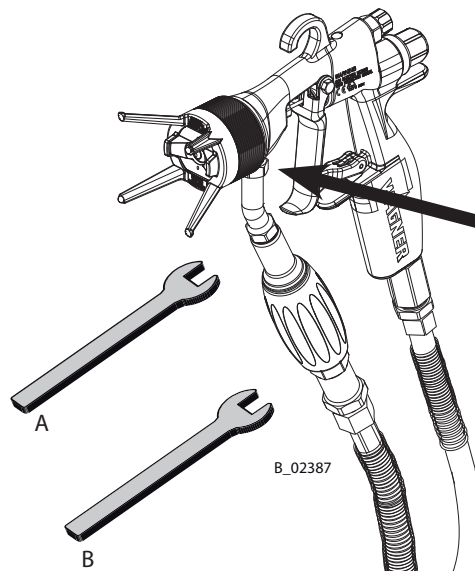

Note:
Do not unscrew the filter connection. The filter connection should be replaced in accordance with Chapter [10.9](#).

9 TROUBLESHOOTING AND RECTIFICATION

Functional fault	Cause	Remedy	See Chapter
Insufficient product output	Nozzle too small	Select larger nozzle.	13
	Product pressure too low.	Increase product pressure.	
	Spray gun filter or high-pressure filter clogged at pump.	Clean or replace filter.	8.2.5
	Nozzle clogged.	Nozzle cleaning	7.4.2
	The valve rod path is too short.	Replace the valve rod.	10.4
Poor spray pattern	Atomizing air incorrectly adjusted.	Readjust the atomizing air.	7.2.1
	Nozzle worn.	Replace the nozzle.	7.4
	Product pressure too low.	Increase the product pressure at pump.	
	The product viscosity is too high.	Dilute the spray product in accordance with the manufacturer's instructions.	
	Nozzle partially clogged.	Nozzle cleaning	7.4 and 7.4.2
	The drilled holes in the air cap are damaged or clogged.	Clean or replace the air cap.	7.4 and 13.2
	Incorrectly selected air cap.	Insert the correct air cap (solvent/water based lacquer).	7.4 and 13.2
Valve rod leaks (paint path or air path)	The seals on the valve rod are damaged or the valve rod itself is damaged.	Replace the entire valve rod or the individual seals.	10.4
	Air valve seals are leaky.	Replace the air valve seal.	10.6
	Pretension is too low.	Tighten the sealing screw.	10.4.3
Spray gun will not shut off correctly	The valve seat or the valve ball is damaged.	Replace the parts.	10.4
	Pretension of the seals is too strong.	Replace the seals.	10.4 and 10.5

10 REPAIR WORK

10.1 REPAIR PERSONNEL

Repair work should be undertaken carefully by qualified and trained personnel. They should be informed of specific hazards during their training.

The following hazards may arise during repair work:

- risk to health from inhaling solvent vapors,
- use of unsuitable tools and aids.

A skilled person must check to ensure that the device is in a reliable state after it is repaired. Carry out function test in accordance with Chapter [11](#).

10.2 REPAIR NOTES

DANGER

Incorrect maintenance/repair!

Danger to life and equipment damage.

- Only a WAGNER service center or a suitably trained person may carry out repairs and replace parts.
- Use only WAGNER original spare parts and accessories.
- Only repair and replace parts that are listed in the "Spare parts" chapter and that are assigned to the unit.
- Before all work on the device and in the event of work interruptions:
 - Relieve the pressure from the spray gun, high-pressure hoses and all devices.
 - Secure the spray gun against actuation.
 - Switch off the energy and compressed air supply.
 - Disconnect the control unit from the mains.
- Observe the operating and service manual for all work.



Before Repair Work

- Flush and clean the system in accordance with Chapter [8.1.2](#).
- Interrupt the air supply.

After Repair Work

- Carry out safety checks in accordance with Chapter [8.2.3](#).
- Put the system into operation and check for leaks as described in Chapter [6.8](#).
- Have the system checked for safe condition by an authorized person.
- Function test in accordance with Chapter [11](#).

10.3 TOOLS

The following tools are required for carrying out the repair work on the gun described below:

- | | |
|--------------------------|---|
| - Open-end wrench, SW 5 | - Socket wrench, size 15 |
| - Open-end wrench, SW 6 | - Mounting key, Order no. 179989 |
| - Open-end wrench, SW 7 | - Nozzle wrench, complete, Order no. 128901 |
| - Open-end wrench, SW 13 | - Torque wrench 12±1 Nm; 8.85 lbft |
| - Open-end wrench, SW 15 | - Pipe wrench |
| - Socket wrench, size 13 | - Pin ø 1.5 mm |

Assembly aids:

Order no.	Quantity	Designation	Smaller tanks
9992831	1 pc = 50 ml	Loctite [®] 542	
9992833	1 pc = 250 ml	Loctite [®] 638 green	
9992590	1 pc = 50 ml	Loctite [®] 222	
9992698	1 pc = 200 g	Vaseline white, PHHV II	
9992616	1 pc = 1 kg can	Molykote [®] DX grease	50 g tube = Order no. 2355419

Brand notice:

The brands specified in this document are property of the respective owners. Loctite[®], for example, is a registered brand of Henkel.

10.4 REPLACING PARTS ON THE VALVE ROD

1. Relieve the pressure of the spray gun and device.
2. Decommission and clean in accordance with Chapter [8.1.2](#).
3. Secure the spray gun with the trigger locking device.
4. Unscrew the spring cap (5) using a size 15 mm; 0.59 inch socket wrench and remove the pressure springs (2) and (3).
5. Loosen the screw (22) and remove together with the nut (20).
6. Remove the trigger (21).
7. Loosen the sealing screw (10) using a size 7 mm; 0.28 inch single open-end wrench.

! NOTICE**Unsuitable tool!**

Damage to seals and sealing surfaces.

→ Do not hold the valve rod with pliers or a similar tool.

8. Carefully pull the valve rod unit (B), together with sealing screw (10), rearwards out of the gun housing (A).
9. Hold the clamping sleeve (4) with a size 6 mm; 0.24 inch open-end wrench and loosen collet chuck (18) with a size 5 mm; 0.20 inch open-end wrench.
10. Carefully pull valve rod (34) out forwards. Replace relevant parts.

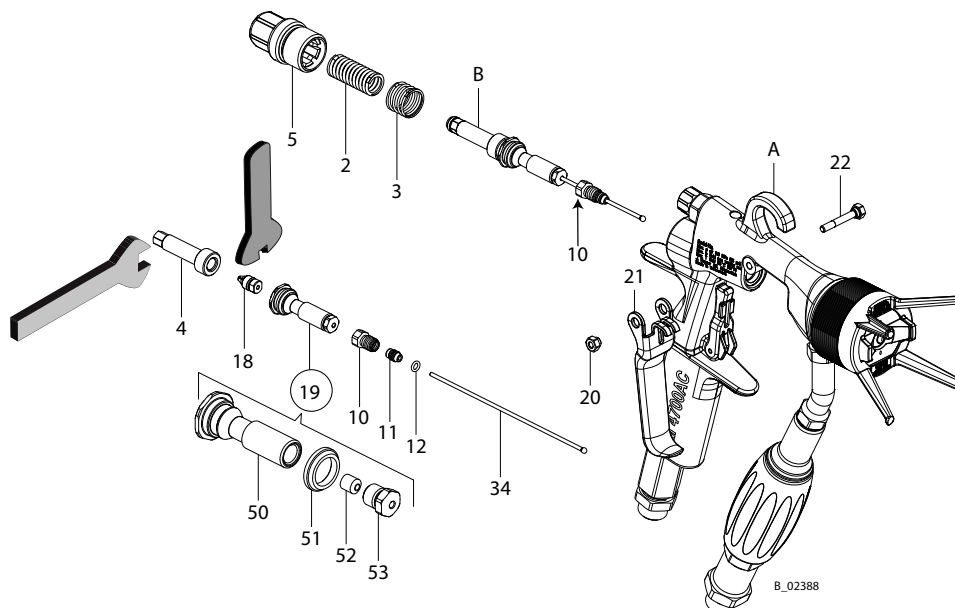

10.4.1 REPLACING VALVE TAPPET SEALS

1. Using a size 13 mm; 0.51 inch open-end wrench, counterhold valve tappet (50) and, using a size 7 mm; 0.28 inch open-end wrench, unscrew cap (53).
2. Remove the air valve seal (51) and seal (52) and replace with new seals. A special tool (order number 179989) is necessary for the assembly of the air valve seal (51).
3. Screw the valve tappet (50) and cover (53) together by hand. Carefully tighten in small increments with a 7 mm; 0.28 inch and 13 mm; 0.51 inch open-end wrench until a slight resistance is perceptible when moving the valve rod (34) in the valve tappet.

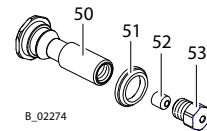
**Note:**

The seal (52) can be pulled out of the cover (53) with the help of an eye bolt.

10.4.2 REPLACING THE ROD SEAL

1. Carefully pull the rod seal (35) out of the gun housing.
2. Clean sealing surfaces in the gun housing.
3. Fit the new rod seal (35) to the rod seal tool (84).

Note:

Note the installation position of the rod seal (35).

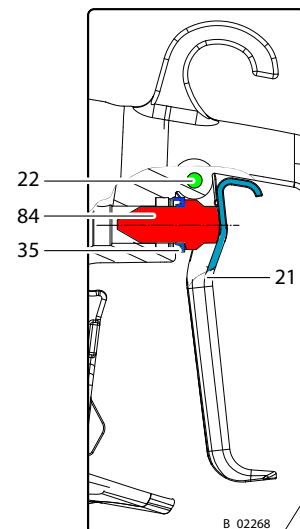
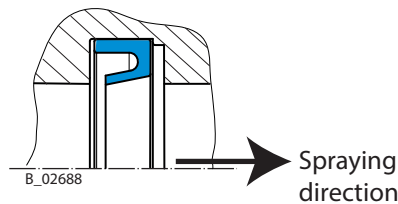

4. Insert the rod seal tool (84) together with the rod seal (35) into the drilled hole.
5. Fit the trigger (21) with screw (22) to the gun body.
6. Carefully push the tool with the rod seal (35) over the trigger (21) into the recess in the housing.
7. Remove the trigger (21), screw (22) and rod seal tool (84).

10.4.3 ASSEMBLY

1. Attach the sealing collar (11) to the valve rod (34) together with the inserted O-ring (12) and sealing screw (10).
2. Push the completely assembled valve tappet (19) onto the valve rod (34).
3. Screw the collet chuck (18) into the clamping sleeve (4) (do not tighten).
4. Insert the preassembled valve rod into the preassembled clamping sleeve (4 and 18) up to the stop.
5. Hold the clamping sleeve (4) with size 6 mm; 0.24 inch wrench in position, screw the preassembled valve rod to the clamping sleeve and tighten with a size 5 mm; 0.20 inch open-end wrench, tightening torque 5 ± 1 Nm; 3.69 lbft. Note reference dimension.
6. Carefully insert the complete valve rod (B) into the gun housing.
7. Screw in the sealing screw (10) but do not tighten yet.
8. Position the trigger (21) and fasten with screw (22) and nut (20).
9. Insert the pressure springs (3) and (2) and screw on the spring cap (5), tightening torque 8 ± 1 Nm; 5.9 lbft.
10. Carefully tighten the sealing collar (11, 12) over the sealing screw (10).
11. Ensure that the trigger moves smoothly.

Note: Only use silicone and resin-free grease.

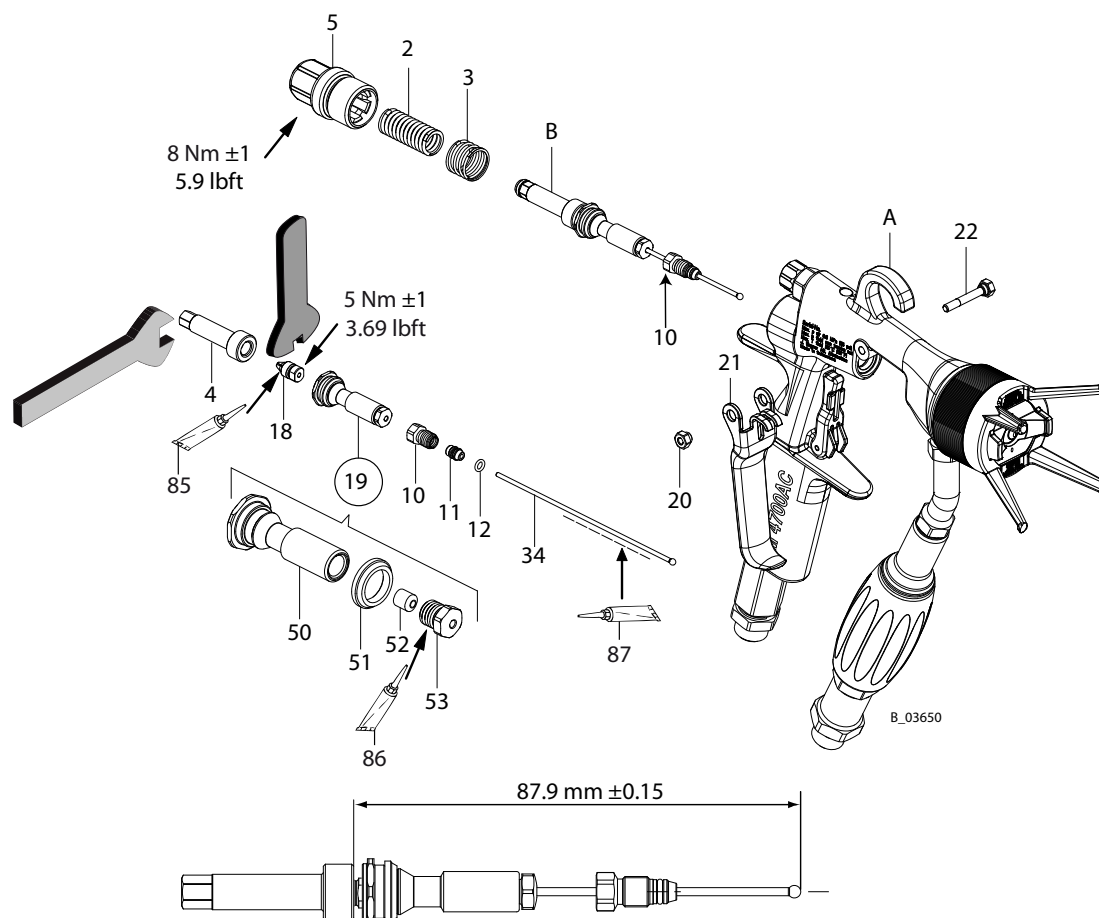

10.5 REPLACING THE NOZZLE SEAL**! NOTICE****Defective nozzle seal!**

Product sprays into the air cap next to the nozzle.

- Do not clean the nozzle seal with sharp-edged objects.
- Replace the nozzle seal if the sealing surface is damaged.

1. Relieve the pressure of the spray gun and device in accordance with Chapter 7.3.
2. Decommission and clean in accordance with Chapter 8.2.1.
3. Secure the spray gun with the trigger locking device.
4. Unscrew the union nut with nozzle guard (33).
5. Remove the air cap (36) together with the nozzle (13).
6. Carefully release the nozzle seal (17) using a screwdriver.
7. Attach the new nozzle seal to the valve housing (16).
8. Continue assembly in the reverse order.

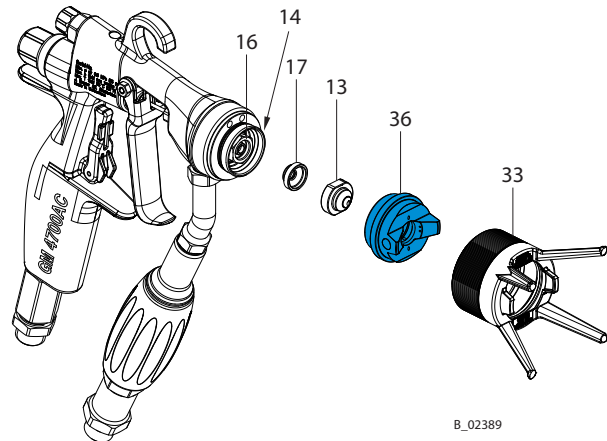

B_02389

10.6 REPLACING THE "AIR" SEALING RING**! NOTICE****Shaping air and atomizer air not separate!**

Poor spray pattern.

Spray jet cannot be adjusted.

- Handle the sealing ring (14) with care.

1. Relieve the pressure of the spray gun and device in accordance with Chapter 7.3.
2. Decommission and clean in accordance with Chapter 8.1.2.
3. Secure the spray gun with the trigger locking device.
4. Unscrew the union nut with nozzle guard (33).
5. Remove the air cap (36) together with the nozzle (13).
6. Remove the defective sealing ring (14/F) with the help of pipe tongs or with a large screwdriver.

Assembly:

7. Plug the new sealing ring (14) onto the air cap (36).
8. Place air cap in body of gun together with sealing ring (14).
9. Attach the union nut (33) and screw it in until the sealing ring snaps into place in the mounting groove (audible snap).
10. Demount the union nut (33) and air cap (36) and complete the spray gun in accordance with Chapter 7.4.

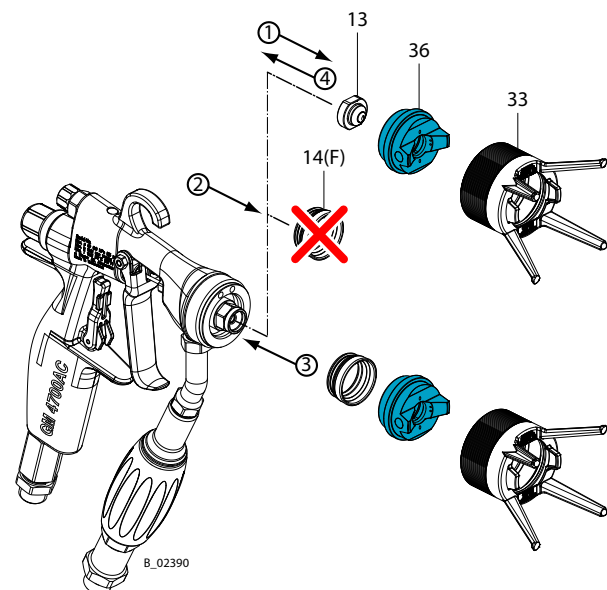

B_02390

10.7 REPLACING THE SEALING FITTING OF THE ROUND JET NOZZLE

! NOTICE

Defective nozzle body!

Poor spray pattern.

→ Handle the nozzle body (A) with care.

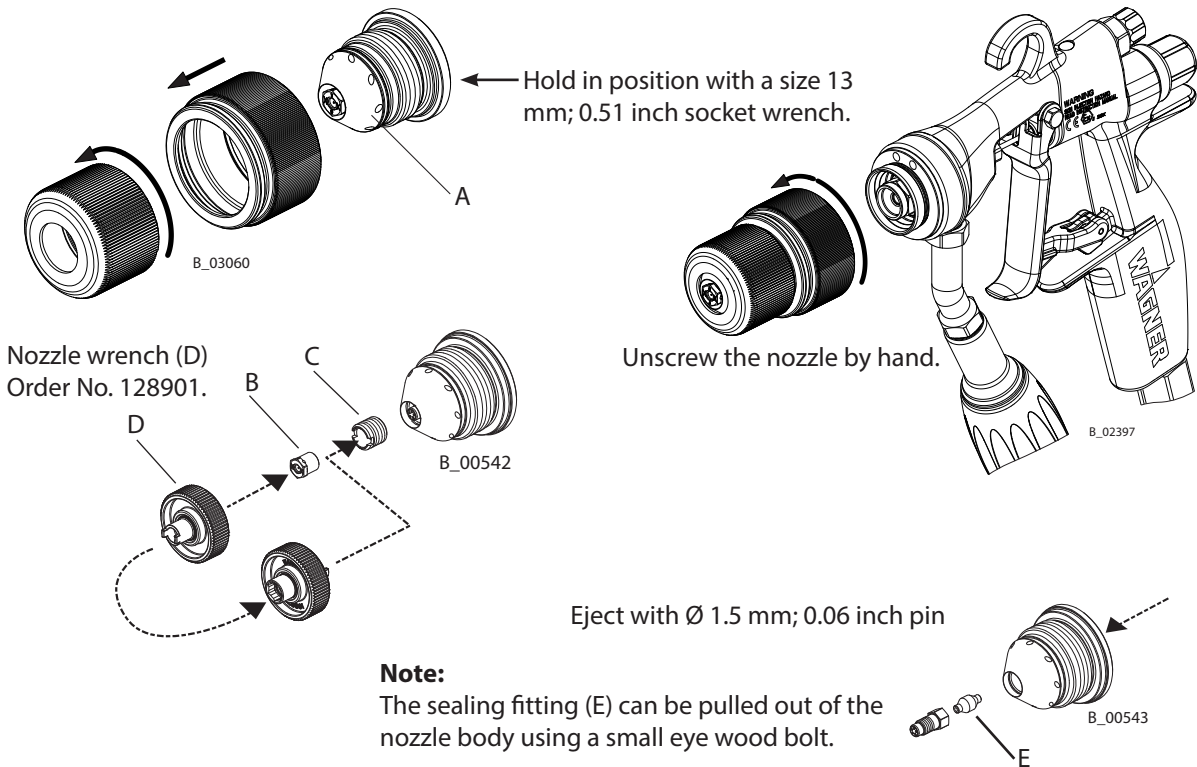

10.8 REPLACING THE SPRING CAP

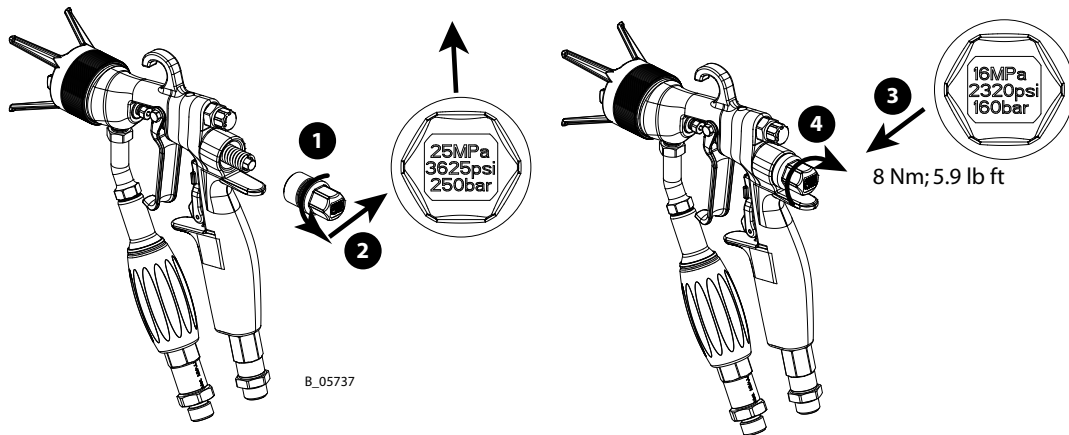

10.9 REPLACING THE FILTER CONNECTION (ONLY GM 4700AC)

The following tools are required for carrying out the repair work on the spray gun described below:

- Filter connection GM 4700AC, complete Order no. 2320114
- Open-end wrench, SW 13; 0.51 inch
- Loctite[®] 638
- Hot-air gun
- Suitable oven for curing the adhesive

10.9.1 DISASSEMBLY**⚠ WARNING****Incompatibility of cleaning agent and working medium!**

Risk of explosion and danger of poisoning by toxic gases.

- Examine the compatibility of the cleaning agents and working media on the basis of the safety data sheets.

**⚠ WARNING****Hot gun housing!**

Burns.

- Wear protective gloves when dismantling the filter connection.



1. Dismount all movable and heat-sensitive (positions X) of the spray gun.
2. Use the air gun to heat the area around the hollow screw to approx. 150 °C; 302 °F.
3. Loosen the hollow screw with a size 13; 0.51 inch open-end wrench, then remove the filter connection.
4. Thoroughly clean all re-usable parts with a suitable solvent.

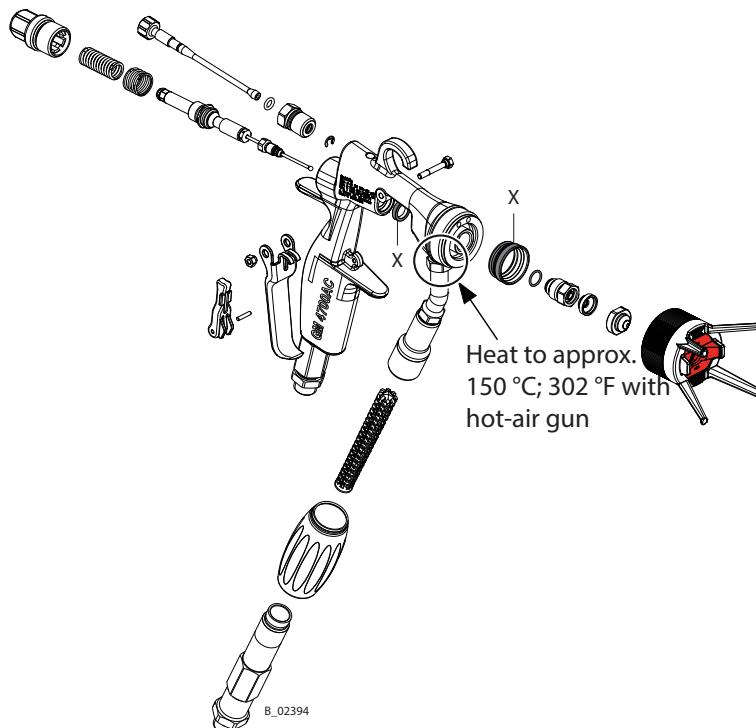

B_02394

10.9.2 ASSEMBLY

1. Apply the Loctite ® 638 to the thread and between the hollow screw and filter connection.
2. Put the filter connection into the gun connection, align and tighten the hollow screw with a tightening torque of 15 Nm; 11 lbft.
Exceeding the allowable torque will damage the filter connection.

⚠ WARNING
Hot gun housing!
 Burns.
 → Wear protective gloves when dismantling the filter connection.



3. Harden the adhesion point in the housing in an oven at 40 °C; 104 °F for at least 30 minutes.
4. After cooling off, completely assemble the spray gun. In doing so, note the assembly information in the spare part drawing in Chapter 14.2 of the operating manual.
5. Use a suitable medium to check the spray gun for leaks at 25 MPa; 250 bar; 3626 psi or 16 MPa; 160 bar; 2320 psi.

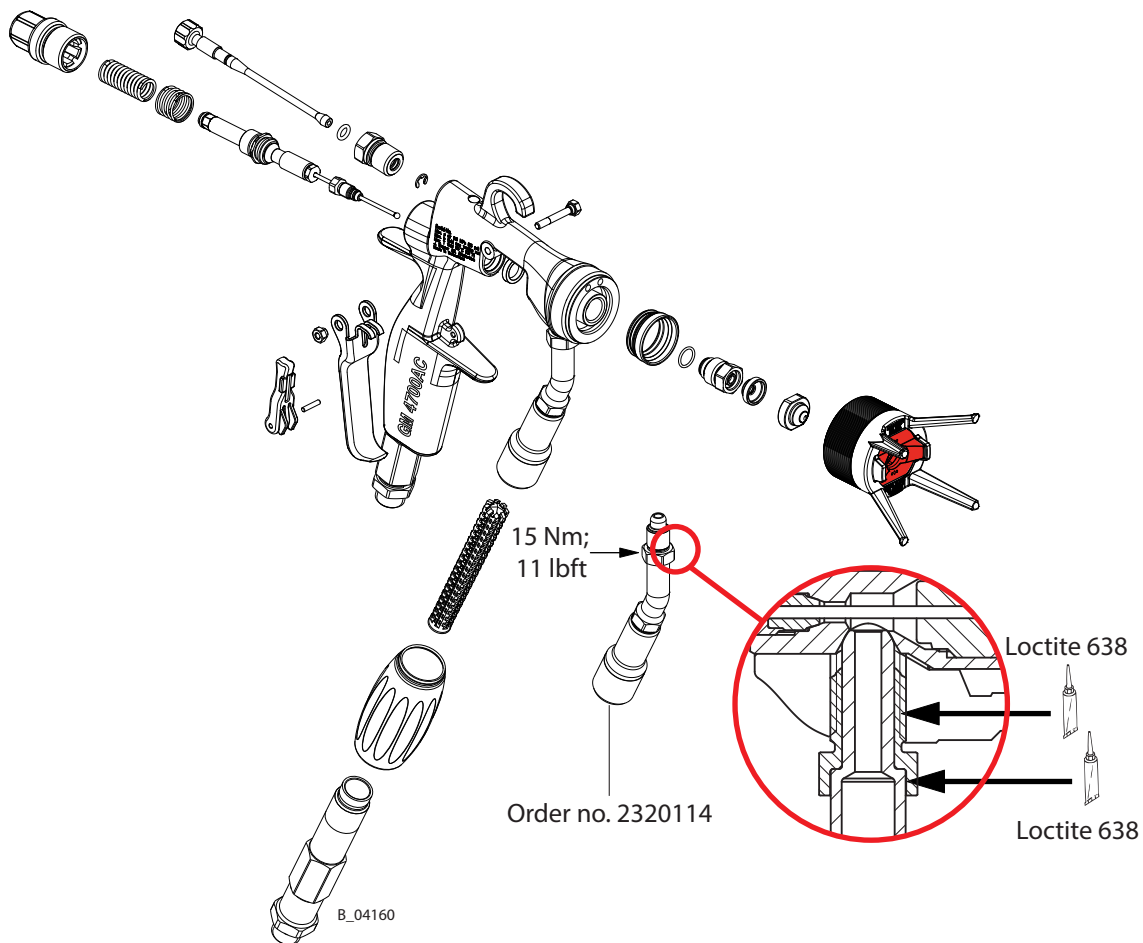

11 FUNCTION TEST AFTER REPAIR WORK

After all repair work, the spray gun must be checked for safe condition before recommissioning. The necessary scope of inspection and testing depends on the repair carried out and must be documented by the repair personnel.

Assembly inspection	
Activity	Means
<p>1. Leak test</p> <ul style="list-style-type: none"> – Connect 1 bar; 0.1 MPa; 14.50 psi and 8 bar; 0.8 MPa; 116 psi air pressure to the air connection and product connection. <p>Place the spray gun completely into the water bath and check all sealing points with 1 bar; 0.1 MPa; 14.50 psi and 8 bar; 0.8 MPa; 116 psi for leaks. At 8 bar; 0.8 MPa; 116 psi bar, the gun must be completely sealed. At 1 bar; 0.1 MPa; 14.50 psi, a slight leak can be tolerated: 5 air bubbles per minute.</p>	<p>Air connection 1 bar / 8 bar</p> <p>Water bath</p>
Injection and Final Inspection	
Activity	Means
<p>2. Trigger lever function test</p> <ul style="list-style-type: none"> – The trigger lever must be pulled as far as it will go. Make sure that the trigger lever can move slightly in its rest position. – Put the trigger lever locking device into the locking position, configure the air product pressure, and pull the trigger lever. Neither air nor product may leak or escape. – Check that the trigger lever locking device is not reset by the trigger lever when pulling in the locking position. 	<p>Manual inspection</p>
<p>3. Leak test</p> <ul style="list-style-type: none"> – Connect the gun, slowly increase the product pressure in increments using a suitable medium until the maximum pressure (250 bar, 25 MPa; 3625 psi or 160 bar, 16 MPa; 2320 psi) specified on the spring cap is reached. – Trigger and flush the spray gun multiple times. – Check the following: <ul style="list-style-type: none"> - Is the product connection sealed when the gun is closed? - Is the product valve sealed? - Is there no product discharge at the valve rod seal? <p>If product leaks, tighten the sealing screw:</p> <p>The sealing screw on the valve rod must be tightened.</p> <p>Tighten the sealing screw with the open-end wrench if necessary. (In doing so, it is important to make sure that the valve rod still runs smoothly and the gun closes reliably).</p>	<p>Visual inspection</p> <p>The 160 bar variant is inspected at 160 bar.</p> <p>250 bar or 160 bar product connection</p> <p>Atomizing air 3 bar</p> <p>Size 7 open-end wrench for the sealing screw</p>

Activity	Means
4. Checking the switching sequence <ul style="list-style-type: none"> – Attach the AC nozzle and air cap. – Set the injection pressure to 100 bar; 10 MPa; 1450.40 psi, pull the trigger slowly, note the switching sequence "switch on" and "switch off". Switch on: atomizing air / shaping air on, product on Switch off: product off, atomizing air / shaping air off 	Visual inspection
5. Flush the spray gun <ul style="list-style-type: none"> – Switch off the air and product supply, open flushing valve, pull trigger lever and flush gun or blow out with air. Flush the gun without the valve and air cap. In doing so, you can remove the air connection hose. – Close the flushing valve. When almost no more product comes out, remove the product connection hose and blow the rest of the test medium out of the spray gun using an air gun. 	

12 DISPOSAL

When the equipment must be scrapped, please differentiate the disposal of the waste materials.

The following materials have been used:

- Stainless steel
- Aluminum
- Elastomers
- Plastic
- Carbide

The consumable products (lacquers, adhesives, solvents) must be disposed of in accordance with the applicable specific standards.

13 ACCESSORIES

13.1 ROUND JET NOZZLE ATTACHMENT

Order no.	Designation
394180	Round jet nozzle attachment (without nozzle insert)

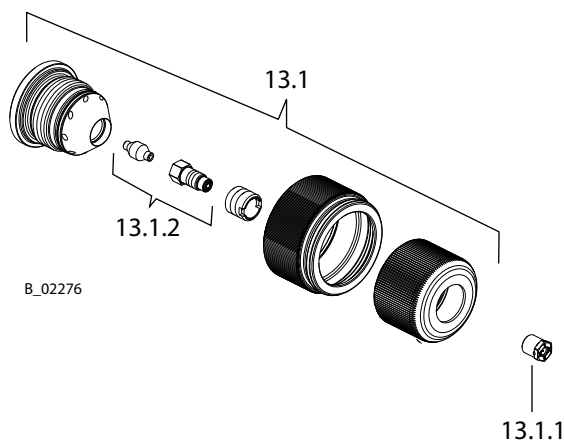

13.1.1 NOZZLE INSERTS RXX

Order no.	Designation	Marking	Volumetric flow rate*	Jet Ø**
132720	Nozzle insert R11	11	0.16; 160	approx. 250; 9.84
132721	Nozzle insert R12	12	0.22; 220	approx. 250; 9.84
132722	Nozzle insert R13	13	0.27; 270	approx. 250; 9.84
132723	Nozzle insert R14	14	0.34; 340	approx. 250; 9.84
132724	Nozzle insert R15	15	0.38; 380	approx. 250; 9.84
132725	Nozzle insert R16	16	0.43; 430	approx. 250; 9.84
132726	Nozzle insert R17	17	0.48; 480	approx. 250; 9.84
132727	Nozzle insert R18	18	0.53; 530	approx. 250; 9.84
132728	Nozzle insert R19	19	0.59; 590	approx. 250; 9.84
132729	Nozzle insert R20	20	0.65; 650	approx. 250; 9.84
132730	Nozzle insert R21	21	0.71; 710	approx. 250; 9.84
132731	Nozzle insert R22	22	0.77; 770	approx. 250; 9.84

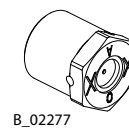

* Volumetric flow in l/min; cc/min water at 10 MPa; 100 bar; 1450 psi

** Jet ø in mm; inches at a distance of 30 cm; 11.8 inches from the object and at a pressure of 10 MPa; 100 bar; 1,450 psi, synthetic resin lacquer, 20 DIN 4 seconds.

13.1.2 NOZZLE SCREW JOINT, COMPLETE

Order no.	Designation
132922	Nozzle screw joint, complete

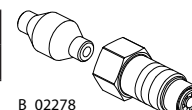

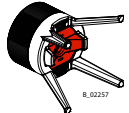
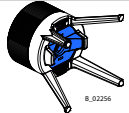
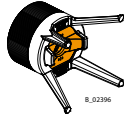

13.2 AIR CAPS

Order no.	Designation	
2313494	Air cap LV plus (red) for low viscosity products	
2313497	Air cap HV plus (blue) for high viscosity products	
2313498	Air cap LA plus (bronze) low air	

13.3 ANODIZED UNION NUT

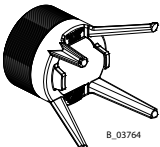
Order no.	Designation	
2330340	Completely anodized union nut (without air cap) suitable for the processing of water-based coatings	

13.4 AIRCOAT NOZZLES ACF3000

Article No. 379xxx In order to determine the article number of a nozzle, please select the number from the table and replace the three xxx.
 Example: nozzle 411 -> article number 379411



Size	Spray angle						
	10°	20°	30°	40°	50°	60°	80°
07	107	207		407			
09		209	309	409	509	609	
11	111	211	311	411	511	611	811
13	113	213	313	413	513	613	813
15	115	215	315	415	515	615	815
17		217	317	417	517	617	817
19		219	319	419	519	619	819
21		221		421	521	621	821
23				423		623	823

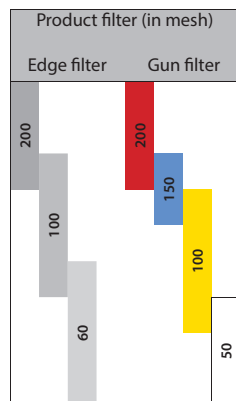

Drilled hole	Product flow*
0,007 (0,18)	0,23 (0,061)
0,009 (0,23)	0,26 (0,069)
0,011 (0,28)	0,38 (0,100)
0,013 (0,33)	0,55 (0,145)
0,015 (0,38)	0,75 (0,198)
0,017 (0,43)	0,96 (0,254)
0,019 (0,48)	1,20 (0,317)
0,021 (0,53)	1,45 (0,383)
0,023 (0,58)	1,79 (0,473)

B_02399

55	100	145	195	250	300	400
(2,17)	(3,94)	(5,71)	(7,68)	(9,84)	(11,81)	(15,75)
∅ Spray pattern width mm (inch)**						

* Tested with water and 100 bar pressure.

** Tested with 110 bar (1595 psi), 30 cm (11.81 inches) distance and lacquer 56DIN-4s.



13.5 AIRCOAT PRE-ATOMIZER NOZZLES AC3000 PLUS

Article No. 321xxx In order to determine the article number of a nozzle, please select the number from the table and replace the three xxx.
 Example: nozzle 410 -> article number 321410



Size	Spray angle				
	20°	30°	40°	50°	60°
08	208	308	408	508	
10	210	310	410	510	610
12	212	312	412	512	612
14	214	314	414	514	614
16	216	316	416	516	616
18	218	318	418	518	618
20		320	420		620
22			422		622

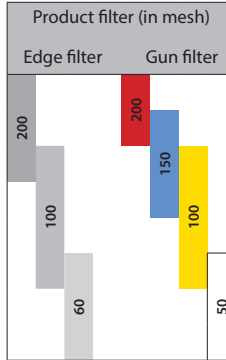

Drilled hole inch (mm)	Product flow* l/min (gal/min)
0,008 (0,20)	0,22 (0,058)
0,010 (0,25)	0,32 (0,084)
0,012 (0,30)	0,44 (0,116)
0,014 (0,36)	0,60 (0,159)
0,016 (0,41)	0,76 (0,201)
0,018 (0,46)	0,92 (0,244)
0,020 (0,51)	0,11 (0,030)
0,022 (0,56)	0,14 (0,036)

B_05736

100	145	195	250	300
(3,94)	(5,71)	(7,68)	(9,84)	(11,81)
∅ Spray pattern width mm (inch)**				



* Tested with water and 100 bar pressure.
 ** Tested with 110 bar (1595 psi), 30 cm (11.81 inches) distance and lacquer 56DIN-4s.

13.6 PUSH-IN FILTER

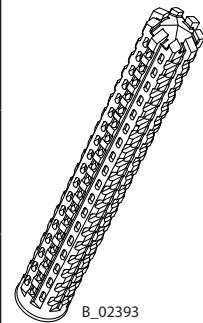
Order no.	Filter sizes	Mesh	Use for nozzles
2315723	Push-in filter, red (10 pieces)	200	0.007" - 0.011"
2315724	Push-in filter, blue (10 pieces)	150	0.011" - 0.013"
2315725	Push-in filter, yellow (10 pieces)	100	0.013" - 0.019"
2315726	Push-in filter, white (10 pieces)	50	0.019" - 0.023"
2315729	Push-in filter, green (10 pieces)	30	0.019" - 0.023"

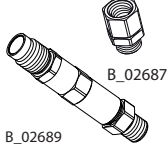
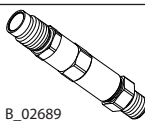

13.7 SWIVEL JOINTS

Order no.	Designation	
394933	Swivel joint set for product (NPSM 1/4") and air hose connection (G1/4")	 B_02689
394928	Swivel joint for product connection (NPSM 1/4")	 B_02689
364938	Swivel joint for air connection G1/4"	 B_02687

13.8 HOSE SETS FOR GM 4700AC

Order no.	Designation
2309705	AC hose set DN3 PN270 1/4"NPS 7.5 m PA T Product: 1/4"NPS, 7.5 m; 24.6 ft, DN 3; ID 0.12 inch, 27 MPa; 270 bar; 3916 psi Air: G1/4", 7.5 m; 24.6 ft, DN 6 mm; ID 0.24 inch, 1 MPa, 10 bar; 145 psi
2309706	AC hose set DN4 PN270 1/4"NPS 7.5 m PA T Product: 1/4"NPS, 7.5 m; 24.6 ft, DN 4; ID 0.16 inch, 27 MPa; 270 bar; 3916 psi Air: G1/4", 7.5 m; 24.6 ft, DN 6 mm; ID 0.24 inch, 1 MPa, 10 bar; 145 psi
2312801	AC hose set DN4 PN270 1/4"NPS 10.0 m PA T Product: 1/4"NPS, 10 m; 32.8 ft, DN 4; ID 0.16 inch, 27 MPa; 270 bar; 3916 psi Air: G1/4", 10 m; 32.8 ft, DN 6 mm; ID 0.24 inch, 1 MPa, 10 bar; 145 psi
2309634	AC hose set DN4 PN270 1/4"NPS 15.0 m PA T Product: 1/4"NPS, 15 m; 49.2 ft, DN 4; ID 0.16 inch, 27 MPa; 270 bar; 3916 psi Air: G1/4", 15 m; 49.2 ft, DN 6 mm; ID 0.24 inch, 1 MPa, 10 bar; 145 psi
2309635	AC hose set DN4 PN270 1/4"NPS 20.0 m PA T Product: 1/4"NPS, 20 m; 65.6 ft, DN 4; ID 0.16 inch, 27 MPa; 270 bar; 3916 psi Air: G1/4", 20 m; 65.6 ft, DN 6 mm; ID 0.24 inch, 1 MPa, 10 bar; 145 psi
2322656	AC hose set DN3 PN270 1/4"NPS 3.0 m PA T Product: 1/4"NPS, 3 m; 9.84 ft, DN 3; ID 0.12 inch, 27 MPa; 270 bar; 3916 psi Air: G1/4", 3 m; 9.84 ft, DN 6 mm; ID 0.24 inch, 1 MPa, 10 bar; 145 psi
9987136	Protective hose, per meter

All AC hose sets consist of a section each of product, air and protective hose.



13.9 HOSE SETS FOR GM 4700AC-H

Use hose sets with sufficient pressure load (35 Mpa; 5076 psi; 350 bar).

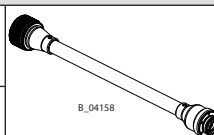
13.10 NOZZLE EXTENSIONS

Order no.	Designation	
394090	Nozzle extension AC 300	 B_04158
394091	Nozzle extension AC 600	

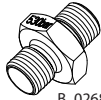
13.11 MISCELLANEOUS

Order no.	Designation	
9997001	Nozzle cleaning brush	
394940	Service set GM 4700AC	
367560	Double connector NPSM1/4" (external thread), for product hose extension	 B_02685
9985720	Double nipple G1/4" (external thread), for air hose extension	 B_02686
2324747	Sealing collar UHMW-PE, complete, suitable for 2K-PU lacquers	 B_04187

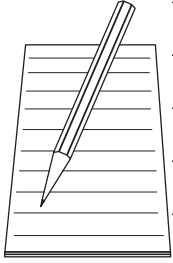

A series of horizontal lines for writing, starting from the top of the page and extending down to the bottom. The lines are evenly spaced and cover most of the width of the page.

14 SPARE PARTS

14.1 HOW CAN SPARE PARTS BE ORDERED?

Always supply the following information to ensure delivery of the right spare part:

Order number, designation and quantity

The quantity need not be the same as the number given in the quantity column "**Stk**" on the list. This number merely indicates how many of the respective parts are used in each component.

The following information is also required to ensure smooth processing of your order:

- address for the invoice,
- address for delivery,
- name of the person to be contacted in the event of any queries,
- type of delivery (normal mail, express delivery, air freight, courier, etc.).

Identification in spare parts lists

Explanation of column "**K**" (labeling) in the following spare parts lists:

- ◆ Wearing parts/ Wearing parts are not included in the warranty terms.
- ★ Included in service set

Notice

These parts are not covered by warranty terms.

- Not part of standard equipment, available, however, as additional extra.

Explanation of order no. column

- Item not available as spare part.
- / Position does not exist.

DANGER

Incorrect maintenance/repair!

Danger to life and equipment damage.

- Only a WAGNER service center or a suitably trained person may carry out repairs and replace parts.
- Use only WAGNER original spare parts and accessories.
- Only repair and replace parts that are listed in the "Spare parts" chapter and that are assigned to the unit.
- Before all work on the device and in the event of work interruptions:
 - Relieve the pressure from the spray gun, high-pressure hoses and all devices.
 - Secure the spray gun against actuation.
 - Switch off the energy and compressed air supply.
 - Disconnect the control unit from the mains.
- Observe the operating and service manual for all work.



Pos	K	Stk	Order no.	Designation
1		1	2313585	GM 4700AC 25 MPa NPSM1/4"
2		1	9999501	Helical spring on the product side
3		1	9999500	Helical spring on the air side
4		1	2312140	Clamping sleeve
5		1	394335	Spring cap 16 MPa; 160 bar; 2320 psi
5		1	394333	Spring cap 25 MPa; 250 bar; 3625 psi
6	◆	1	394924	Air tappet, complete
8	◆	1	2311320	Valve rod unit, complete
10		1	394327	Sealing screw
11	★ ◆	1	394328	Sealing collar
11	◆ ●	1	2324747	Sealing collar UHMW-PE, complete (including pos. 12)
12	★ ◆	1	9971445	O-ring
13	◆ ●	1	379xxx	AC nozzle (see Chapter 13.4)
13	◆ ●	1	321xxx	AC nozzle plus (see Chapter 13.5)
14	★ ◆	1	394339	Sealing ring
15	★ ◆	1	9974245	O-ring
16	★ ◆	1	394922	Valve housing, complete
17	★ ◆	1	394338	Nozzle seal
18		1	2312149	Collet chuck
19		1	394257	Valve tappet, complete
20		1	394318	Nut
21		1	394601	Trigger
22		1	394319	Screw
23		1	394334	Safety clip
24		1	9935088	Parallel pin
25		1	394313	Air tappet
26	★ ◆	1	9974243	O-ring
27		1	394303	Mounting bracket
28	★ ◆	1	9921906	Lock washer
29		1	2324766	Air swivel, complete
34	★ ◆	1	394920	Valve rod, complete
35	★ ◆	1	394323	Rod seal
36	◆ ●	1	2313494	Air cap LV plus (red)
36	◆ ●	1	2313497	Air cap HV plus (blue)
36	◆ ●	1	2313498	Air cap LA plus (bronze)
50		1	394309	Valve tappet
51	★ ◆	1	179338	Air valve seal
52	★ ◆	1	179395	Seal
53	★ ◆	1	394322	Cap
55	●	1	394336	Nozzle body
56	◆ ●	1	128327	Sealing fitting
57	◆ ●	1	132516	Nozzle screw joint, complete
58	●	1	132351	Nozzle screwed connection holder
59	●	1	394308	Union nut
60	●	1	394337	Nozzle nut
61	◆ ●	1	132...	Nozzle insert R (various dimensions see Chapter 13.1.1)
62	●	1	394180	Round jet nozzle attachment (see Chapter 13.1.)
63	◆ ●	1	132922	Nozzle screw joint, complete

◆ = Wearing part

★ = Included in service set

● = Not part of the standard equipment but available as a special accessory

Pos	K	Stk	Order no.	Designation
64	◆	1	--	Filter insert, yellow (middle), 100 mesh per inch*
	◆ ●	1	2315723	*Filter insert, red (fine), 200 mesh per inch, 10 pieces
	◆ ●	1	2315724	*Filter insert, blue (middle), 150 mesh per inch, 10 pieces
	◆ ●	1	2315725	*Filter insert, yellow (middle), 100 mesh per inch, 10 pieces
	◆ ●	1	2315726	*Filter insert, white (coarse), 50 mesh per inch, 10 pieces
	◆ ●	1	2315729	*Filter insert, green (coarse), 30 mesh per inch, 10 pieces
65	★ ◆	1	128389	Seal
66	◆	1	2311491	Turning handle
67		1	2320016	Filter housing, complete
68		1	2320114	Filter connection GM 4700AC, complete
69	●	1	2352651	Spring cap 35 MPa; 350 bar; 5076 psi
70	★ ●	1	--	Pressure spring for spring cap 35 MPa; 350 bar; 5076 psi
	●	1	394941	Service set GM 4600/4700AC

◆ = Wearing part

★ = Included in service set

● = Not part of the standard equipment but available as a special accessory

14.2.1 ASSEMBLY AIDS GM 4700AC AND GM 4700AC-H

Pos	K	Bestellnr.	Designation
80	●	9992831	Loctite [®] 542
81	●	9992833	Loctite [®] 638 green
82	●	9992590	Loctite [®] 222
83	●	9992609	Anti-seize paste
84	★ ●	394342	Tool valve rod seal
85	●		Molykote [®] DX grease
86	●	9992528	Loctite [®] 270
87	●	9992698	Vaseline white, PHHV II
88	●	179989	Tool air valve seal

★ = Included in service set

● = Not part of the standard equipment but available as a special accessory

Pos	K	Stk	Order no.	Designation
1		1	2315700	GM 4700AC-H, 35 MPa NPSM1/4"
2		1	9999501	Helical spring on the product side
3		1	9999500	Helical spring on the air side
4		1	2312140	Clamping sleeve
5		1	394333	Spring cap 25 MPa; 250 bar; 3625 psi
6	◆	1	394924	Air tappet, complete
8	◆	1	2311320	Valve rod unit, complete
10		1	394327	Sealing screw
11	★ ◆	1	394328	Sealing collar
11	◆ ●	1	2324747	Sealing collar UHMW-PE, complete (including pos. 12)
12	★ ◆	1	9971445	O-ring
13	◆ ●	1	379xxx	AC nozzle (see Chapter 13.4)
13	◆ ●	1	321xxx	AC nozzle plus (see Chapter 13.5)
14	★ ◆	1	394339	Sealing ring
15	★ ◆	1	9974245	O-ring
16	★ ◆	1	394922	Valve housing, complete
17	★ ◆	1	394338	Nozzle seal
18		1	2312149	Collet chuck
19		1	394257	Valve tappet, complete
20		1	394318	Nut
21		1	394601	Trigger
22		1	394319	Screw
23		1	394334	Safety clip
24		1	9935088	Parallel pin
25		1	394313	Air tappet
26	★ ◆	1	9974243	O-ring
27		1	394303	Mounting bracket
28	★ ◆	1	9921906	Lock washer
29		1	2324766	Air swivel, complete
34	★ ◆	1	394920	Valve rod, complete
35	★ ◆	1	394323	Rod seal
36	◆ ●	1	2313494	Air cap LV plus (red)
36	◆ ●	1	2313497	Air cap HV plus (blue)
36	◆ ●	1	2313498	Air cap LA plus (bronze)
50		1	394309	Valve tappet
51	★ ◆	1	179338	Air valve seal
52	★ ◆	1	179395	Seal
53	★ ◆	1	394322	Cap
55	●	1	394336	Nozzle body
56	◆ ●	1	128327	Sealing fitting
57	◆ ●	1	132516	Nozzle screw joint, complete
58	●	1	132351	Nozzle screwed connection holder
59	●	1	394308	Union nut
60	●	1	394337	Nozzle nut
61	◆ ●	1	132...	Nozzle insert R (various dimensions see Chapter 13.1.1)
62	●	1	394180	Round jet nozzle attachment (see Chapter 13.1.)
63	◆ ●	1	132922	Nozzle screw joint, complete

◆ = Wearing part

★ = Included in service set

● = Not part of the standard equipment but available as a special accessory

Pos	K	Stk	Order no.	Designation
64	◆	1	--	Filter insert, yellow (middle), 100 mesh per inch*
	◆ ●	1	2315723	*Filter insert, red (fine), 200 mesh per inch, 10 pieces
	◆ ●	1	2315724	*Filter insert, blue (middle), 150 mesh per inch, 10 pieces
	◆ ●	1	2315725	*Filter insert, yellow (middle), 100 mesh per inch, 10 pieces
	◆ ●	1	2315726	*Filter insert, white (coarse), 50 mesh per inch, 10 pieces
	◆ ●	1	2315729	*Filter insert, green (coarse), 30 mesh per inch, 10 pieces
65	★ ◆	1	128389	Seal
66	★ ◆	1	2311491	Turning handle
67		1	2320016	Filter housing, complete
69	◆	1	9998910	Instruction label "hot surfaces"
70	◆	1	9998911	Protection label for 9998910
71	●	1	2352651	Spring cap 35 MPa; 350 bar; 5076 psi
72	★ ●	1	--	Pressure spring for spring cap 35 MPa; 350 bar; 5076 psi
	●	1	394941	Service set GM 4600/4700AC

◆ = Wearing part

★ = Included in service set

● = Not part of the standard equipment but available as a special accessory

15 EU DECLARATION OF CONFORMITY

Herewith we declare that the supplied version of:

GM 4700AC 25 MPa

GM 4700AC-H 25 MPa

complies with the following guidelines:

2006/42/EC
2014/34/EU

Applied standards, in particular:

EN ISO 12100:2010	EN 1127-1:2011
EN 1953:2013	EN ISO 80079-36:2016
EN ISO 13732-1:2008	EN ISO/IEC 80079-34:2011
EN 14462:2015	--

Applied national technical standards and specifications, in particular:

DGUV regulation 100-500 Chapter 2.29
DGUV regulation 100-500 Chapter 2.36
TRGS 727

Identification:   II 2G X

EU Declaration of Conformity

The EU Declaration of Conformity is enclosed with this product. If needed, further copies can be ordered through your WAGNER dealer by specifying the product name and serial number.

Order number: 2316429

WAGNER



Document No. 11099801
Version H

Order no. 2311730
Edition 06/2018

Germany

J. Wagner GmbH
Otto-Lilienthal-Str. 18
Postfach 1120

88677

Markdorf

Phone +49/ (0)7544 / 5050
Telefax +49/ (0)7544 / 505200
E-Mail ts-liquid@wagner-group.com

Switzerland

Wagner International AG
Industriestrasse 22

9450

Altstätten

Phone +41/ (0)71 / 757 2211
Telefax +41/ (0)71 / 757 2222

More contact addresses:

www.wagner-group.com

Subject to changes without notice