



FILTERED WATER PITCHER

Quick-Start Guide





Congrats & Welcome

Congrats on your new Clearly Filtered Water Pitcher. You've made a wise investment in your health.

Like you, we have high standards for our water. That's why we developed your pitcher's filter with our renowned Affinity® Filtration Technology; the most powerful filtration technology on the planet. Now you can finally stop worrying about what's in your water.

In this short guide, we'll show you how to upgrade your water from questionable to clean, reveal the benefits of our breakthrough technology, and ensure you make the most of your Clearly Filtered experience.

TABLE OF CONTENTS	PAGE
What Makes Us Superior	3
How Affinity® Filtration Technology Works	4
A Look Inside Your Filter	5
Filter Prep & Replacement	6
Tested, Trusted, & Transparent	9
Setup	11
Quick Tips	17
Troubleshooting	18
Help & Resources	18
Next Steps	19
Warranty	20

What Makes Clearly Filtered Superior?

The Clear Difference

Others focus on taste. **We focus on safety.**

Others reduce some contaminants. **We reduce more contaminants.**

Others say cleaner. **We say cleanest.**

By The Numbers

365+

Standard pitcher filters capture as few as 5 contaminants. **Our pitcher filter captures more than 365 contaminants.**

6

A dynamic water pathway + a powerful blend of 6 superior filtration materials join forces to produce the cleanest, safest, and healthiest water possible.

100

Our filters have a 100-gallon life. That's up to 4 months longer than the industry standard.

How Affinity® Filtration Technology Works

In 2017, Affinity® Filtration Technology made waves as the new standard for water safety.

Thanks to our decade-long journey developing the technology in your filter, “better tasting” and “better smelling” water is no longer the gold standard of safety. After all, Simple carbon or charcoal filters focus on reducing unpleasant odors and tastes. Their basic technology leaves you vulnerable as hundreds of harmful contaminants that can't be seen, smelled, or tasted remain in your water.

Our filters never fall short. The breakthrough technology inside targets and **removes up to 99.99% of 365+ contaminants**. This includes those dangerous chemicals, metals, and toxins that most filters miss. Here's how our technology transforms your water from polluted to pure.

In its simplest form, Affinity® Filtration Technology leverages 2 cutting-edge components:

- 1** **A dynamic physical structure:** The maze-like interiors of our filters require water to pass through twists and turns to give the filter more time to capture and filter contaminants. That alone means superior performance.
- 2** **A potent contaminant magnet:** The precise and powerful collection of unique medias in our filters separate the good and the bad. They identify and bond to dangerous contaminants others miss, and do not target beneficial minerals.

Ultimately, Affinity® Filtration Technology recognizes what should stay and what should go. Its one-two punch of structure and magnets helps target dangerous chemicals, metals, and toxins other filters can't.

A Look Inside Your Filter

Here's a quick look at the filtration components inside your pitcher's filter:



Stage 1: Screening Layer

This delicately woven protective layer keeps larger particles and sediment out of the filter, and out of your water.

Stage 2: Granulated Carbon Layer

Primes water for advanced filtration by capturing common contaminants that affect taste and smell.

Stage 3: Proprietary Composite Layer

6+ proprietary filtration medias target the toughest contaminants that the vast majority of filters miss.

Filter Prep & Replacement

Your Clearly Filtered Water Pitcher comes with one filter. The components inside your filter work synergistically to provide you with the cleanest water. **Your filter must be primed before first use to deliver superior results. Then it must be replaced regularly to maintain performance.**

Priming Your Filter

Every filter **must** be primed before first use to perform properly. Priming is the process of preparing the filter by forcing water through it. This simple step pushes air out of the filter, loosens up the filtration media, and ensures it's ready for water to flow through so contaminants are captured.

Refer to the 'Setup' section on page 11 of this guide for detailed priming instructions.

Replacing Your Filter

To maintain peak performance, a filter change is recommended at every 100 gallons filtered*. Your pitcher's top reservoir holds 1/2 gallon of water. That means if you fill the top reservoir twice a day, your filter should be changed every 100 days (or roughly every 3 months).

If you are not tracking gallons, follow the guidelines below for replacing your filter:

3+ People: Replace filter every 2-3 months.

2 People: Replace filter every 3-4 months.

1 Person: Replace filter every 4-6 months.

**Filter life can be impacted by water quality.*

Filter Autoship

Keep your pitcher performing its best by regularly replacing the filter. Enroll in our filter autoship service to ensure you always have a replacement ready and you never forget to reorder.

Filters are mailed straight to your doorstep at no additional cost and you're rewarded with a discount on every filter.

Autoshipping is the simplest, quickest, and most cost-effective way to guarantee you have clean water year-round and to make the most of your Clearly Filtered experience.

Additional benefits:

- Save 10% on every filter.
- Free shipping (USA).
- Pick your preferred shipping frequency.
- Pause, skip, and adjust shipping frequency, or cancel at any time.
- No long-term contract required.

Get Enrolled

If you purchased your pitcher without a filter autoship and do not need a replacement filter immediately, please contact our support team to create an account and get enrolled. Our support staff is available Monday-Friday 9am-4pm PT (excluding holidays).

4 Easy Ways To Get Enrolled:

1. Select “Autoship & Save 10%” during checkout of your next purchase.
2. Email our support team at info@clearlyfiltered.com.
3. Live chat with a team member at clearlyfiltered.com (M-F 9am-4pm PT).
4. Call our support team at +1 (877) 876-2740 (M-F 9am-4pm PT).

Manage Your Account Online

To manage your filter autoship, activate your Clearly Filtered account with the email address you used to purchase your pitcher. Then go to ClearlyFiltered.com/Account to log in. Here you can update your address and payment information, pause, skip, or adjust shipping frequency, and cancel your autoship. You always have complete control of your account.

Tested, Trusted, & Transparent

Our filters have been independently tested to the rigorous NSF/ANSI standards by accredited labs.

While the EPA regulates less than 100 tap water contaminants, our filtered water pitcher is effective against 365+ contaminants for your protection. **Plus, we test all of our filtration systems against EPA-regulated contaminants at 3-10x the established legal limits to guarantee performance in extreme conditions.**

We also keep an eye on unregulated and emerging contaminants. When a new or emerging contaminant is discovered, we look to test our filters and share the results on our website.

Remember, the contaminants we target and filter can be linked to everything from cancer, thyroid conditions, and bone disease to liver, kidney, and reproductive problems. Our ongoing commitment to clean water ensures you can count on us to cover your health, your family, and your future.



Tested



Trusted



Transparent



ClearlyFiltered



Setup

Components

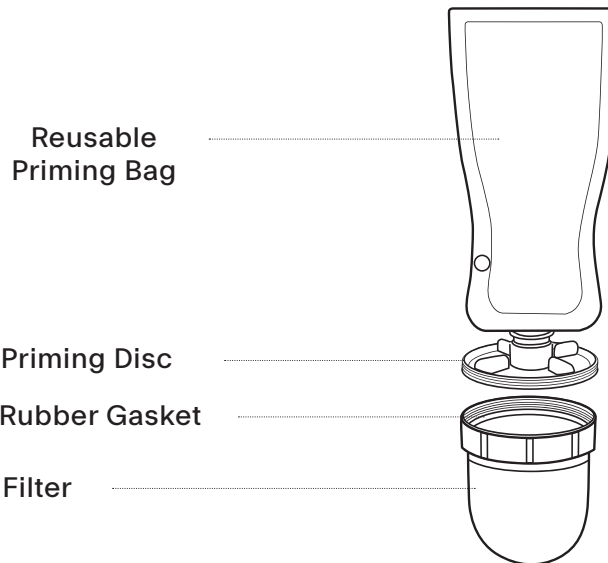
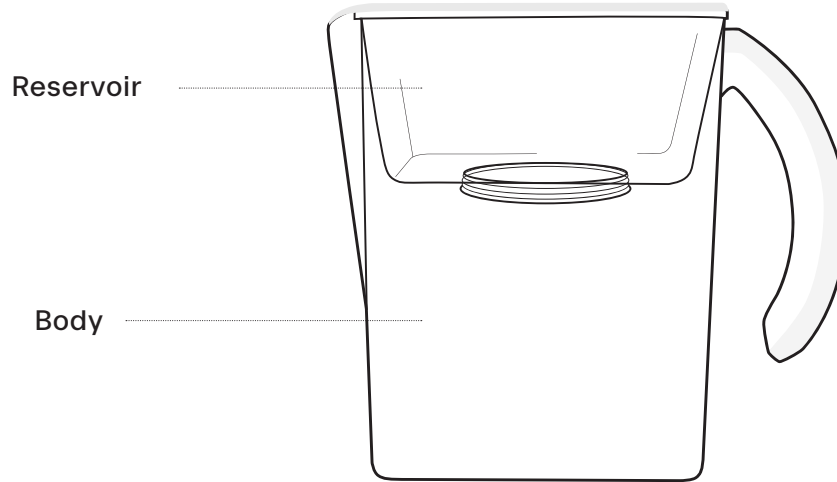

Scan Here

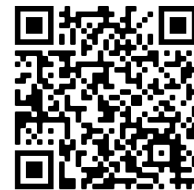

Installation
Video Tutorial

STEP 1

REMOVE STICKER

- 1 Hand twist the disc to disconnect the priming bag from the filter.

Please note: The priming disc and priming bag should always remain connected to one another throughout the priming process.

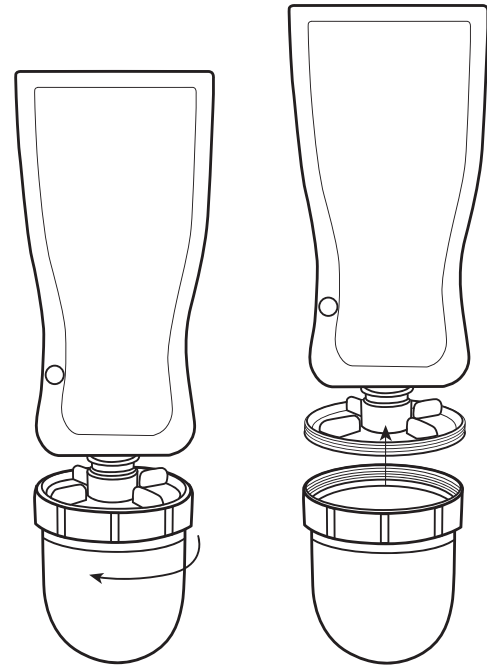

- 2 Remove the blue protective sticker covering the filter's intake holes.

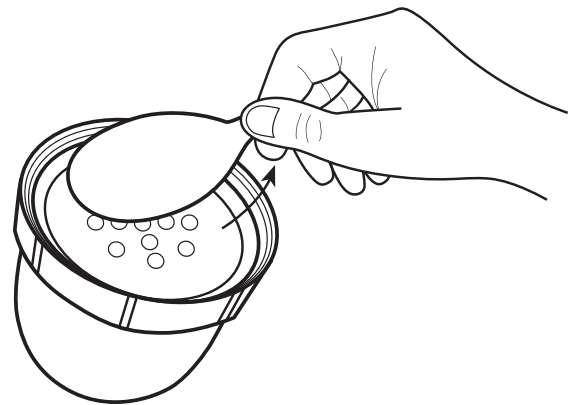

STEP 2

PRIME FILTER (DO NOT SKIP)

To ensure your filter works efficiently and effectively, you must prime it prior to first use.

- 1 Flip the included priming bag upside down so the priming disc is facing the faucet. Hold the disc below the faucet, then turn the cold water on gradually until a steady stream of cool water flows through the disc's hole into the bag.



- 2 Run water until the bag is full.

- 3 Once the bag is full, twist the threaded base of the filter (flat side) onto the disc until snug to create a seal between the two.

Ensure the rubber gasket stays in place on the filter when twisting the filter onto the disc.

- 4 Flip the bag right side up so the filter is oriented beneath the bag.

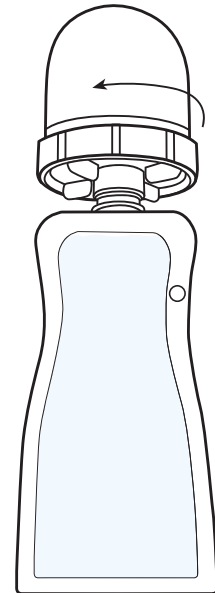

- 5 Hold the bag over the sink, then forcefully squeeze it with both hands to force the water inside down through the filter. Squeeze hard enough to see water dripping out of the bottom of the filter. We recommend using the same amount of pressure as you would to force the last few drops of toothpaste out of a tube. Continue to squeeze the bag until empty.

Please note: It is normal for water to escape from the edges of the priming disc and spill over the edges of the filter where the two components connect.

- 6 Repeat this process 2-3 times by refilling the priming bag, then squeezing the bag to force the water inside through the filter. Water dripping out of the filter is a sign that the filter is now primed and activated.

- 7 Once the bag is empty, hand twist the filter to disconnect it from the disc and bag. Pour out any remaining water left.

Please note: Save the priming bag in a cool, dry location for future use.

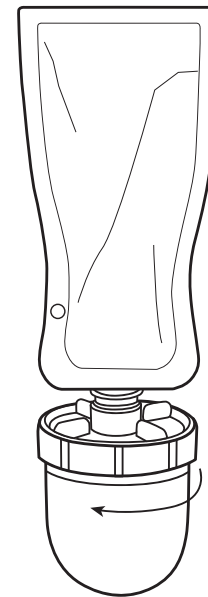
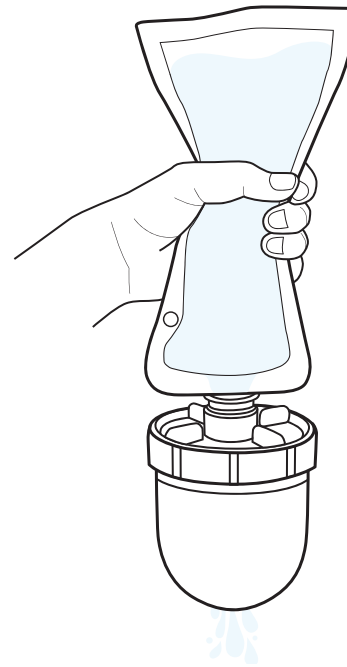

STEP 3

CONNECT FILTER TO RESERVOIR

- 1 Remove the back lid from the reservoir, then pull out the reservoir.

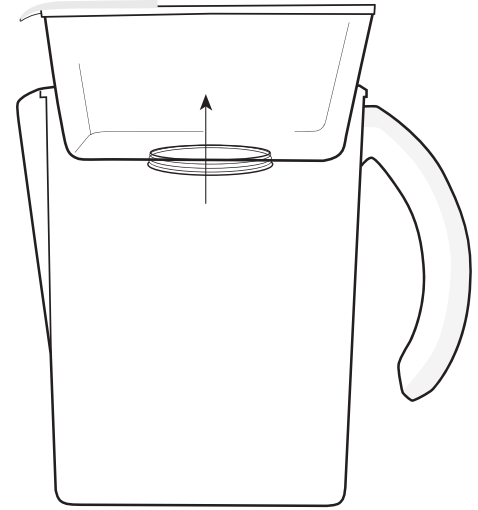

- 2 Twist the filter onto the threaded base of the reservoir.

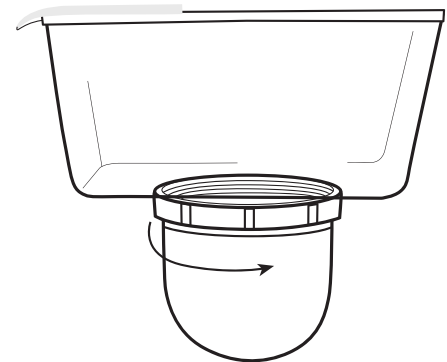

STEP 4

INSTALL & ENJOY

- 1 Place the filter and reservoir into the pitcher body.
- 2 Fill the reservoir with cold or room temperature tap water.
- 3 Slide the back lid on top of the reservoir until it clicks into place.
- 4 Enjoy your clean and safe water.

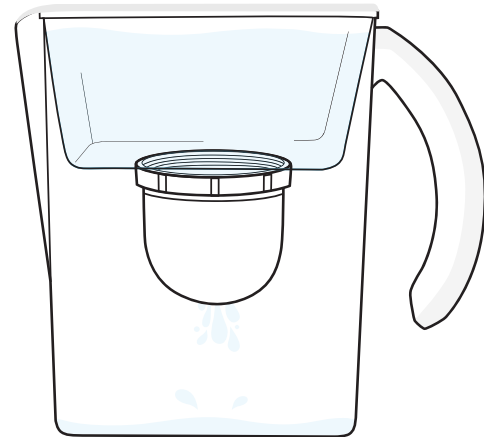

Quick Tips

Your filter is built for cold tap water only. Do not attempt to filter hot water.

Superior filtration takes time. A full reservoir of water can take up to 35 minutes to filter. This means your filter is doing its job to make every drop as clean as possible.

Never wash your filter with soap, however your pitcher body can be hand washed with soap and water regularly.

Replace your filter every 100 gallons filtered. For most customers, this is every 3-4 months. See the 'Filter Prep & Replacement' section of this guide for more details.

Go to <https://clearlyfiltered.com/products/clean-water-pitcher-replacement-filter> to get replacement filters and learn more about our filter autoship service.

Always store the priming bag and any unused filters in a cool, dry location.

Troubleshooting

Pressure is key to force water through the filter during step 2 of setup; 'Prime Filter'. That's why we recommend squeezing the bag forcefully with two hands.

If your filter is leaking, remove then reattach it to the base of the reservoir to ensure the gasket is securely in place.

If you find filtration is taking more than 35 minutes, "soak" your filter by leaving it submerged upright in tap water in a large bowl, container or glass for 4-6 hours.

Excessive sediment can slow down and prematurely clog your filter. If filtration is taking abnormally long, check the sediment levels of your water.

Help & Resources

Need help with your pitcher?

We have a friendly support team and a library of online resources dedicated to you.

Here are 4 easy and convenient ways to get help:

- Visit our Help & FAQs page at help.clearlyfiltered.com.
- Email our support team at info@clearlyfiltered.com.
- [Live chat](#) with a team member at clearlyfiltered.com.
- Call our support team at **+1 (877) 876-2740**.

**Business Hours: M - F 9am-4pm PT; excluding holidays.*

Get More Clean Water

Experience Our Full Line of Premium Products

Can't get enough clean water? Visit ClearlyFiltered.com to learn more about our full line of premium products.

We have filters for everything including bottles, refrigerators, and sinks, so you can enjoy the benefits of clean water at home and on the go.



Filtered Water Pitcher



Replacement Filters



Filtered Water Bottles



3-Stage Under Sink System



Fridge Filter

Warranty

All Clearly Filtered products are manufactured to the highest standard and are individually inspected prior to shipping.

We offer a limited lifetime warranty on all items:

To view our full policy, please visit our warranty page at ClearlyFiltered.com/Warranty

Join the Movement:

Stay clear on the latest and greatest by visiting ClearlyFiltered.com.

Connect with us on social media to tap into our Clearly Filtered family:



[/ClearlyFiltered](https://www.facebook.com/ClearlyFiltered)



[@Clearly_Filtered](https://www.instagram.com/Clearly_Filtered)



[ClearlyFiltered](https://www.youtube.com/ClearlyFiltered)

When Do I Change My Filter?

Your filter must be replaced regularly to deliver superior results. Based on proven performance data, tracking usage is the best way to determine the right time for a filter change.

Use the chart below to estimate your usage and find out when to change your filter:

Step 1.

Determine how many people use the filter (Bottom of chart).

Step 2.

Estimate how many glasses of water each person uses per day (Left side of chart).

Step 3.

Trace your inputs to determine when you'll need a filter change (Middle of chart).

Change Tracker Chart

Daily glasses of water per person	10+ GLASSES	5 MONTHS	2 MONTHS	2 MONTHS	1 MONTH	1 MONTH	1 MONTH
	9-10 GLASSES	6 MONTHS	3 MONTHS	2 MONTHS	2 MONTHS	1 MONTHS	1 MONTH
	7-8* GLASSES	6 MONTHS	3 MONTHS	3 MONTHS	2 MONTHS	2 MONTHS	1 MONTH
	5-6 GLASSES	6 MONTHS	4 MONTHS	3 MONTHS	3 MONTHS	2 MONTHS	2 MONTHS
	3-4 GLASSES	6 MONTHS	5 MONTHS	4 MONTHS	3 MONTHS	3 MONTHS	2 MONTHS
	1-2 GLASSES	6 MONTHS	6 MONTHS	6 MONTHS	6 MONTHS	5 MONTHS	4 MONTHS
		1 PERSON	2 PEOPLE	3 PEOPLE	4 PEOPLE	5 PEOPLE	6 PEOPLE

of people drinking from the pitcher

* 8 Glasses of Water

is the physician-recommended daily intake



Time To Change My Filter

Record your filter installation date below. Then use the 'Change Tracker Chart' on the previous page to estimate your filter replacement date. Record the estimated replacement date below for easy reference.

Filter Installation Date

Date 1

Date 2

Date 3

Date 4

Date 5

Date 6

Filter Replacement Date

Date 1

Date 2

Date 3

Date 4

Date 5

Date 6

