



HYPERSCORPION OWNER'S MANUAL

TABLE OF CONTENTS

Introduction	1	Initial Ride	16
Safety	2	Safety Check Before Each Ride	16
Before Riding the E-Bike.....	2	Using the Brakes	16
While Riding the E-Bike.....	3	Shifting the Gears	16
Off-Road Riding.....	3	Pedal Assist Control System	17
Wet-Weather Riding.....	4	Using the Pedal Assist Control System	17
Night Riding.....	4	Throttle Operation	18
Extreme and Aggressive Riding.....	4	Reading the Battery Pack Level	18
Electric Bicycle Safety.....	4	Understanding the Battery Pack Range	18
10 Safety Topics from the U.S. Government.....	5	Factors that Will Decrease Your Range	19
General Information	6	How to Increase Your Range	19
Features.....	6	Advanced Matrix Display Overview.....	20
Electronic Modules.....	11	Button Overview.....	20
Specifications.....	11	Main Display Screen Overview	21
Assembly	12	Battery Voltage (Volts).....	21
Installing the Front Wheel.....	12	Headlight Graphic.....	21
Installing the Handlebars.....	13	Assist Level.....	21
Installing the Pedals.....	14	Power (Watts).....	21
Adjusting Ride Comfort.....	14	Battery Level Graphic.....	21
Operation	16	Speed (mph or km/h).....	21
		Trip Distance (mi or km).....	21
		Turning the E-Bike On and Off	22
		How to Turn the E-bike On	22

**California
Proposition 65 Warning**

Certain components in this product and its related accessories contain chemicals known to the state of California to cause cancer, birth defects or other reproductive harm. Wash hands after handling.

DISCLAIMERS:

All information, illustrations and specifications in this manual are based on the latest information available at the time of publishing. This e-bike is under a continuous improvement policy. Thus, information, illustrations and/or specifications to explain and/or exemplify a product, service or maintenance improvement may be changed at any time without notice.

- How to Turn the E-bike Off..... 22
- Automatic Shutoff..... 22
- Adjusting the Assist Levels 22**
 - How to Increase the Assist Levels 22
 - How to Decrease the Assist Levels 22
- Activating the LED Headlight..... 23**
 - To Turn On the Halo Light 23
 - To Turn On the full Headlight..... 23
- Activating the Walk Mode 23**
 - To Activate the Walk Mode 23
 - To Stop Using the Walk Mode 23
- Activating the Cruise Control Function 23**
 - To Activate the Cruise Control Function..... 23
 - Important Notes About the Cruise Control Function..... 24
- Resetting the Trip Counter 24**
 - To Reset the Trip, Ah, and Wh Counter to Zero..... 24
- Activating the Advanced Display Screen..... 24**
 - This Data Includes 25
 - To Toggle Between the Main Screen and the Advanced Display Screen..... 25
- Understanding the Advanced Display Mode 25**
 - Voltage..... 25
 - Amps..... 25
 - Power..... 25
 - Amp-Hours..... 25
 - Watt-Hours 25
 - Assist Level..... 25

- Speed 26
- Controller Temperature..... 26
- Trip Distance 26
- Adjusting Parameters in the Setup Menu 26**
 - To Enter the Settings Menu 26
 - Available Menu Options 26
 - Navigating and Entering a Menu Setting..... 26
 - Unit 26
 - Speed Limit..... 27
 - Backlight 27
 - Wheel Size 27
 - “Power Off” Delay 27
 - NDW..... 27
 - NDW Setting 27
 - Torque 27
 - Low Volts..... 28
 - Error Codes..... 29
- Maintenance 30**
 - Battery 30
 - Removing the Battery Pack 30
 - Charging the Battery Pack 30
 - Onboard Charging..... 32
 - Hydraulic Brakes..... 32
 - Mineral Oil Cups..... 32
- Troubleshooting 33**

- Basic Troubleshooting 33**
- Juiced Bikes Warranty 34**
 - Covered Products 34
 - Warranty Period..... 34
 - Warranty Exclusions..... 34
 - The Scope of Warranty Service..... 36
 - Severability 36
 - Shipping Damage Claims..... 36



INTRODUCTION

THANK YOU FOR CHOOSING TO BE PART OF THE JUICED BIKES TEAM.

We invite you to read through this *Owner's Manual* to learn about your e-bike and what owning an e-bike looks like.

First and foremost, remember to be safe out there. Your bike is an accessory to your lifestyle and activities. Always follow the best practices and traffic rules.

Even in an evolving technology, your e-bike is a bike at heart, so it will require basic maintenance and care to always perform properly.

Preventive maintenance is the name of the game. We invite you to grow with us, taking advantage of the modular design we use for our technology.

Instructions, videos and live support are being created to offer all the knowledge you need to understand your Juiced Bike and get the best out of it.

Contact Information

Juiced Bikes
1669-A Brandywine Ave.
Chula Vista, CA 91911, USA

Tel: +1-888-303-8889 (option 3 for support)

support@juicedbikes.com

www.JuicedBikes.com

1 SAFETY

⚠️ WARNING

Indicates a hazardous situation which, if not avoided, could result in death or serious injury.

NOTICE

Indicates a situation which can cause damage to the e-bike, personal property, and/or the environment, or cause the e-bike or equipment to operate improperly.

In e-biking, as in cycling, the user's safety is paramount. It's important to understand that e-bike riders tend to ride e-bikes at greater speeds than traditional bicycles and e-bikes are therefore more dangerous. Be sure to understand and follow all local laws and regulations and to have maintenance/repairs done by an authorized Juiced Bikes dealer. Never use/ride any Juiced Bikes product in ways unintended by the manufacturer and never exceed the weight limit of any product.

⚠️ WARNING

Do not operate this product in traffic or any other environment that may present danger until you are confident with the product and all installed accessories such as lights, passenger seat, etc. Failure to do so could result in death or serious injury.

Use only parts/accessories approved by Juiced Bikes, and have all installation performed by a mechanic authorized by Juiced Bikes. Installation of unauthorized parts/accessories may void the product's warranty. In addition, improper installation of any parts/accessories as well as improper maintenance may void the product's warranty.

⚠️ WARNING



Never disassemble or modify any electronic component of the bicycle. Doing so is extremely dangerous and could result in death, serious injury or void the warranty.

⚠️ WARNING



Never ride your e-bike under the influence of alcohol or drugs.

⚠️ WARNING



Always review your state & local laws before allowing a minor to ride an e-bike. In many states, including California, riders must be 16 and older to operate a Class 3 e-bike.

Always wear a helmet, whether the law requires one or not! Wear a properly fitting ANSI or Snell (CE for Europe) approved bicycle safety helmet at all times when riding the e-bike.

Wear shoes that will grip the pedals and stay on your feet. Be sure shoelaces cannot become caught in moving parts. Never ride barefoot or wear sandals.

Wear eye protection to prevent dirt, bugs and other airborne objects from entering your eyes. Wear tinted eye protection when the sun is bright.

Wear proper fitting clothing that is not too loose. Loose clothing can be caught in moving parts and become snagged by objects alongside the road or trail.

BEFORE RIDING THE E-BIKE

Always perform a mechanical check before riding the e-bike:

- Hardware is properly fastened
- Tires are properly inflated
- Brakes properly operate
- Handlebars are adjusted and secured
- Front wheel is secure & properly locked

WHILE RIDING THE E-BIKE

Obey all rules of the road and local traffic laws.

Respect motorists, pedestrians and other cyclists. Do not race or taunt other cyclists.

Ride defensively since others may not see you. Do not follow other cyclists or vehicles too close.

Ride alertly and watch for:

- Cars turning in front of you
- Parked car doors opening
- Children and pets
- Road or trail conditions such as potholes, sewer grates, railroad tracks and other obstructions

Ride in lanes and trails designated for bikes.

Obey traffic stop signs and lights.

Use appropriate hand signals for turning and stopping.

Do not wear headphones.

Never carry an adult passenger.

Never carry anything that obstructs your vision or compromises control of the e-bike.

Never hold on to moving vehicles to hitch a ride.

Do not make any moves that could surprise other people with whom you share the road. Never weave through traffic.

Avoid riding when:

- Visibility is poor, such as dawn, dusk or in the dark
- Bad weather
- Rider is extremely tired
- E-Bike maintenance is needed

OFF-ROAD RIDING

Off-road riding requires paying close attention and using specific skills. Practice riding in easier terrain to build up your skills. Obey local laws pertaining to off-road riding.



Always wear appropriate safety gear.

Always ride with a companion in remote areas.

Always carry a form of identification so others know who you are in case of an accident.

Yield the right-of-way when pedestrians and animals are present.



WET-WEATHER RIDING

 WARNING	
	Avoid riding in wet weather if possible. Reduce your speed if necessary to ride in wet weather. Wet weather impairs visibility, braking and traction of the e-bike and affects others sharing the road. Accidents increase in wet weather conditions.

NIGHT RIDING



Night riding is far more dangerous than riding during the day. Be sure to wear reflective clothing. Verify that you comply with local laws about night riding.

Reflectors are not a substitute for required lights. Reflectors help others see you by picking up and reflecting car lights and streetlights. Be sure the reflectors are in good condition before riding at night. Do not remove the reflectors from the e-bike.

 WARNING	
	Be sure to use an adequate lighting system when riding at night or at any other times of poor visibility. Riding at night or at any other times of poor visibility without an adequate lighting system and without reflectors may result in death or serious injury.

If necessary, equip the e-bike with an aftermarket battery or generator lighting system.

EXTREME AND AGGRESSIVE RIDING

 WARNING	
	The e-bike design has limitations regarding strength and integrity. Extreme, stunt and competition riding can exceed those limitations. The manufacturer does not recommend these types of riding. Also, extreme, stunt and competition riding increases the risks of death and serious injury.

If you choose to ride extremely and aggressively, at least:

- Take lessons from a competent instructor.
- Start easy and slowly develop your skills.
- Wear a full-face mask helmet and other safety equipment.
- Understand the stress imposed on the e-bike.
- Do not ride the e-bike if it is damaged.
- Most importantly, understand your skills and experience.

ELECTRIC BICYCLE SAFETY

- Always review your state & local laws before allowing a minor to ride an e-bike.
- For maximum stability, avoid accelerating or braking while turning.

- Avoid riding in extremely wet conditions.
- Do not leave the e-bike in the rain.
- Discontinue the use of the e-bike if the battery pack is damaged due to a crash or a drop.
- Do not ride up or down extremely steep inclines.
- Do not ride off-road or jump the e-bike.
- Always use the kickstand or center stand when not on the bicycle.
- Do not exceed the carrying capacity.
- Do not ride on sand.
- The motor can get hot; do not touch the body of the motor for at least 2 hours after riding.
- Brake disc rotors can get extremely hot for brief periods after braking.
- Stay alert. Always keep a lookout for obstacles in your path.
- Go with the flow. The safe way is the RIGHT way.
- Check for traffic. Always be aware of the traffic around you.
- Learn rules of the road. Obey traffic laws.
- Don't flip over your bicycle. Wheels should be securely fastened.

10 SAFETY TOPICS FROM THE U.S. GOVERNMENT

- Protect your head. Wear a helmet.
- Assure bicycle readiness. Make sure your bicycle is adjusted properly.
- Stop it. Always check brakes before riding.
- See and be seen.
- Avoid biking at night.

FEATURES

An e-bike is similar to a normal bicycle. The major difference is the addition of an electric motor that provides a boost when desired. An onboard rechargeable lithium battery pack supplies the motor with electric power. Users can ride the bicycle using both pedal power and battery pack power at the same time.

The controller regulates how much power the battery pack sends to the motor. The controller is located under the seat.

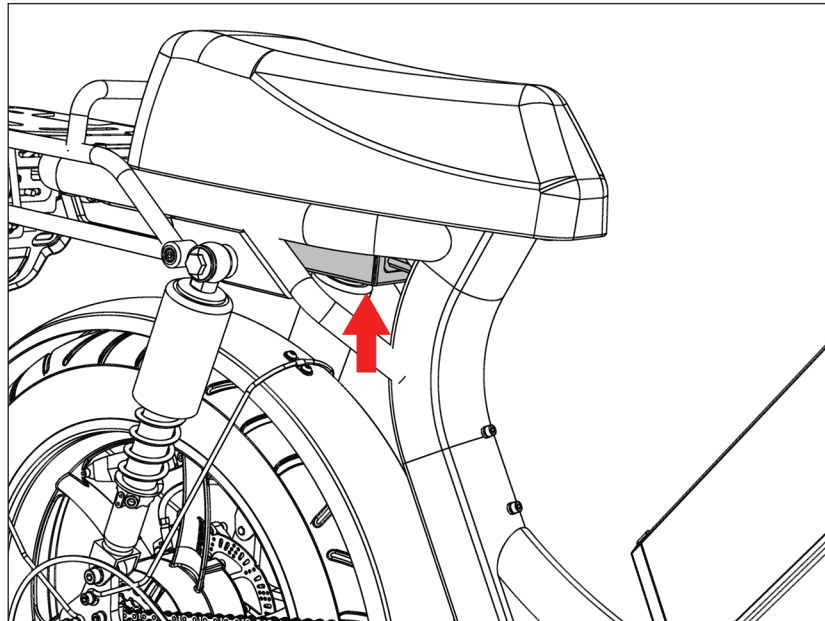

Fig. 1 - Controller

Throttle - The throttle allows the rider to ride the bike & control the bike's speed without pedaling. It sends a signal to the controller telling it how much power to send to the motor. The throttle is located on the right handlebar.

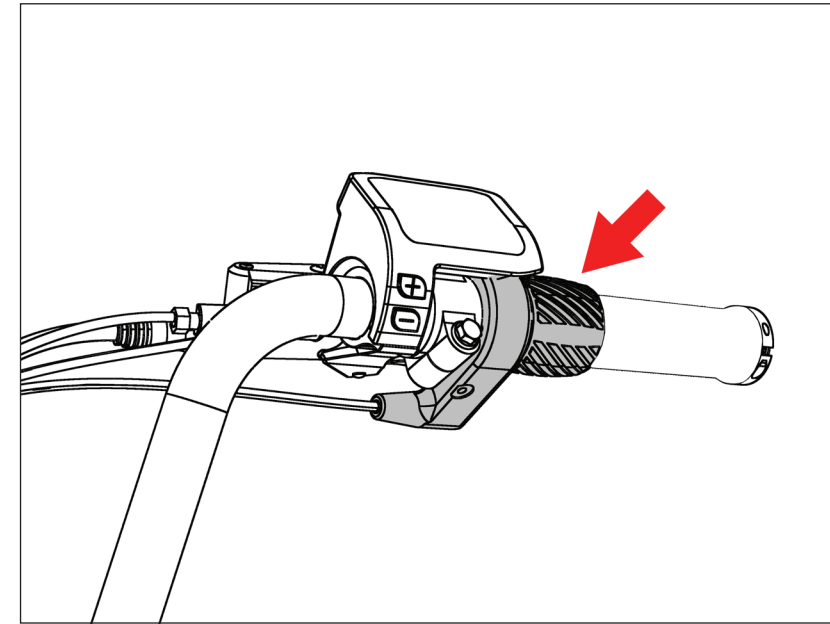

Fig. 2 - Throttle

Battery Pack - The battery pack stores electrical energy. It is composed of many smaller battery pack cells that act similar to that of a modern mobile phone.

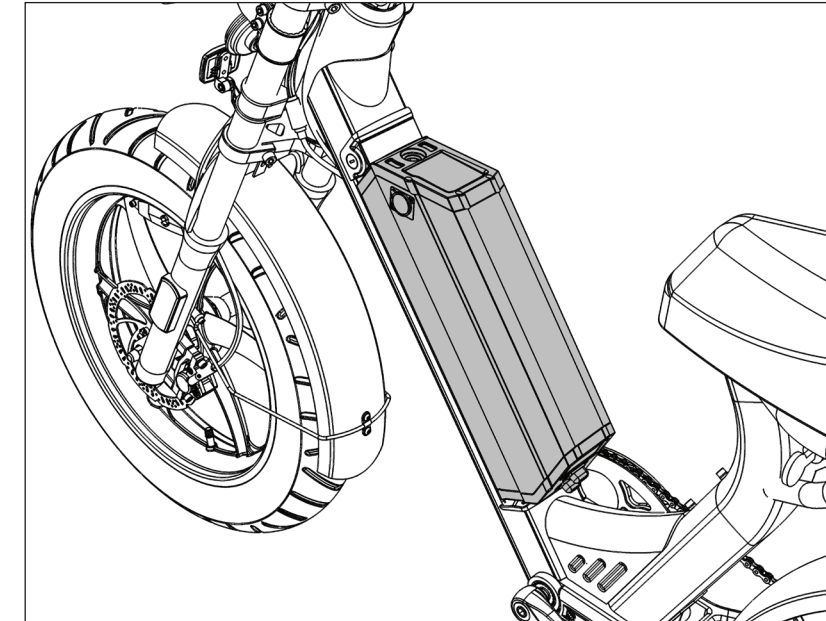

Fig. 3 - Battery Pack

LCD Display - The display reads the battery pack's voltage. This will provide an estimate of the battery pack's charge state. The display may have other buttons to control other functions.

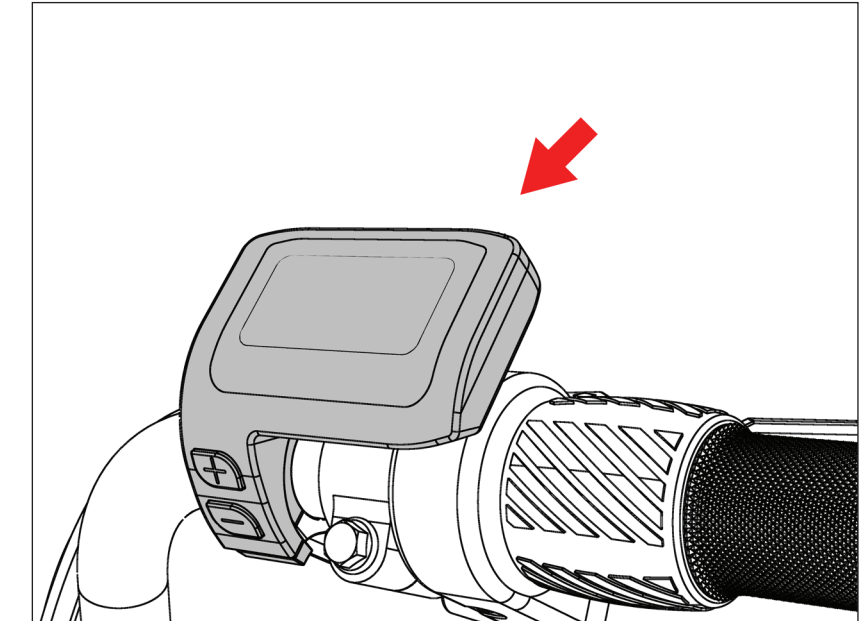

Fig. 4 - LCD Display

Electric Motor - The electric motor is built into the hub of the rear wheel. When power reaches the motor, the motor begins to spin, propelling the bike forward.

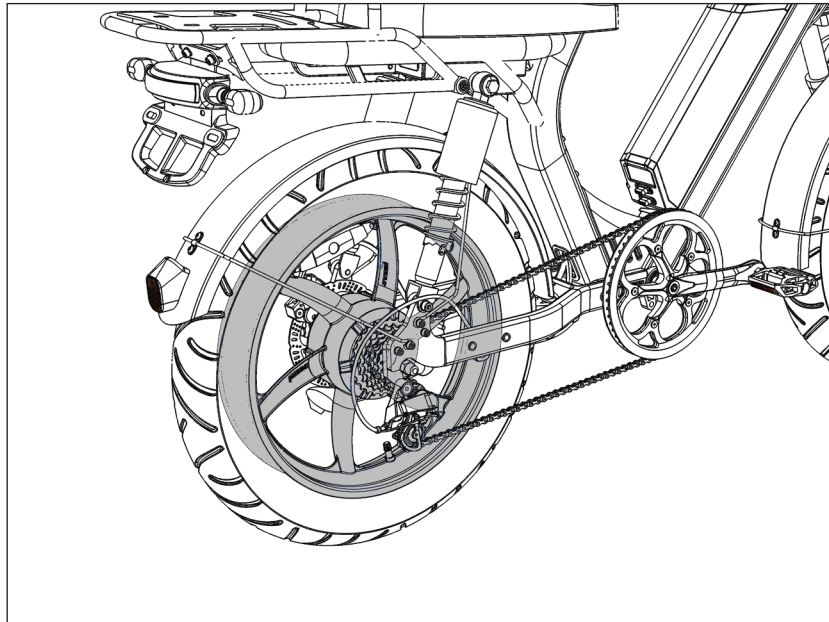

Fig. 5 - Electric Motor

Gear Shifter - The gear shifter changes the ratio between the pedals and the rear wheel. Use it to find a more comfortable pedaling cadence under different riding conditions. Try the low gear for pedaling during starts, uphill or loaded riding. Choose the higher gears when pedaling downhill or during faster riding. The gear shifter is located on the left handlebar.

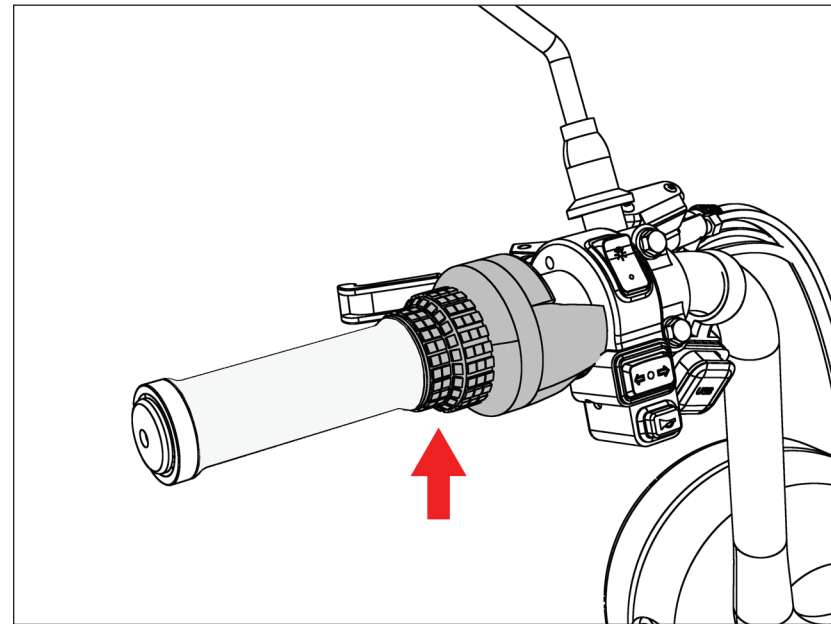

Fig. 6 - Gear Shifter

Brakes - The brakes use friction to slow the bike down. The levers on the handlebars control the braking. The brakes have an electrical switch that cuts the power to the electric motor when the rider uses the brakes. This feature prevents unintentional accelerations while braking.

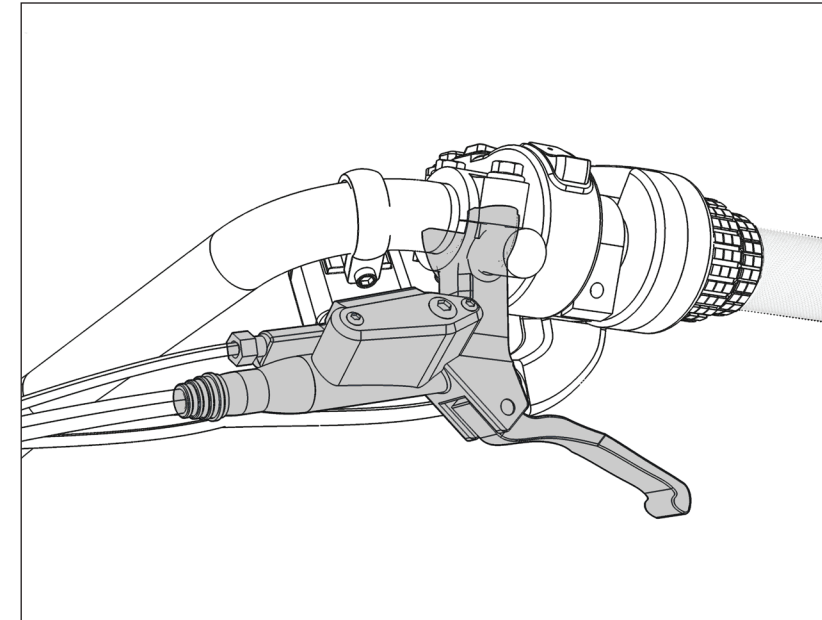

Fig. 7 - Brake Lever

Fuse - The battery pack has two replaceable 30-amp fuses that protect the electronics.

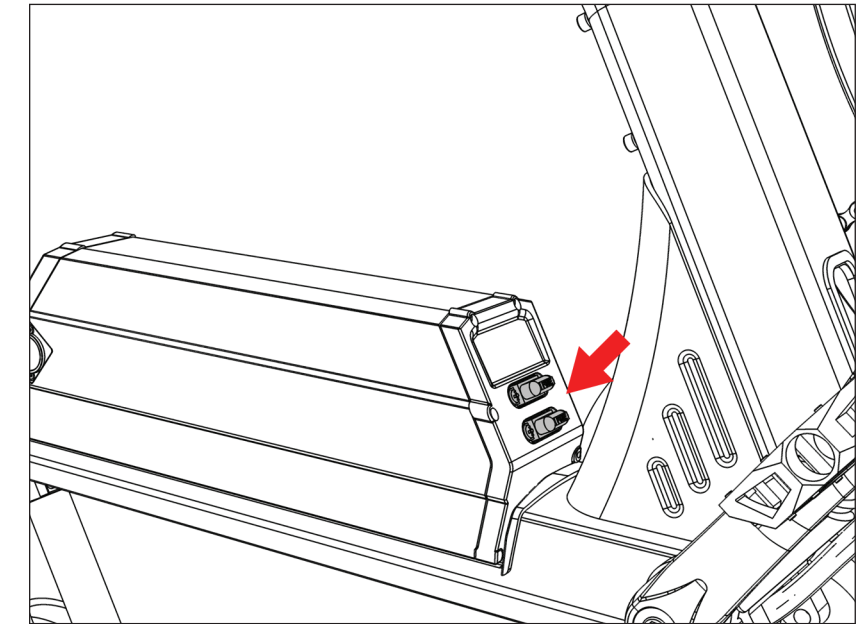

Fig. 8 - Fuse

Visually inspect your shipping box and the e-bike to see that everything arrived without shipping issues. Take pictures if you suspect excessive rough handling and contact support@juicedbikes.com.

Watch our assembly videos and feel free to invite a handy friend. Call us with any assembly questions. Also, you can e-mail support@juicedbikes.com and we can send you more specific information. We often generate new user guides based on the feedback we receive from our customers.

Charge the battery pack. See “Charging the Battery Pack” on page 30.

NOTICE

The kickstand is designed to support the e-bike only. Do not sit on the e-bike with the kickstand engaged. Sitting on the e-bike with the kickstand engaged could result in damaged to the kickstand.

NOTICE

The front wheel must be inspected before every ride to ensure it is securely attached to the bike. Failure to test that the front wheel is properly secured could result in significant injury or even death.

INSTALLING THE FRONT WHEEL

Remove the shipping spacer, bolt and nut from the front wheel fork.

1. Remove the spacer between the front disc brake caliper. Do not squeeze the front brake handle. Squeezing the front brake handle will cause the pads to move and it may be difficult to position the front brake disc within the pads.

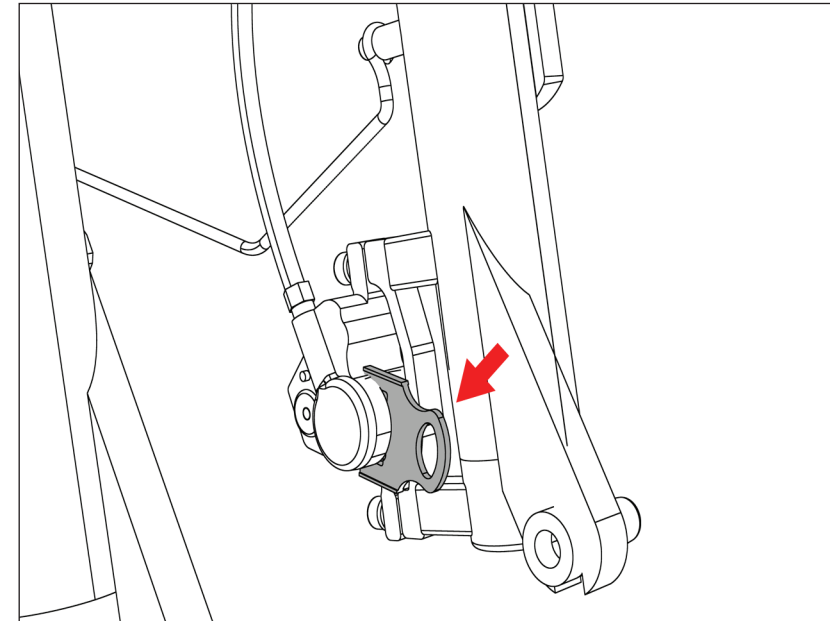

Fig. 10 - Removing Shipping Spacer

2. Insert the axle into the front wheel hub. Position the wide spacer (chain drive side) and slim spacer (disc brake side) on the axle. Insert the front wheel in between the forks while positioning the front brake disc in the brake caliper. Spacers must be in between the forks.
3. Place a washer onto the axle on the outside of the forks.

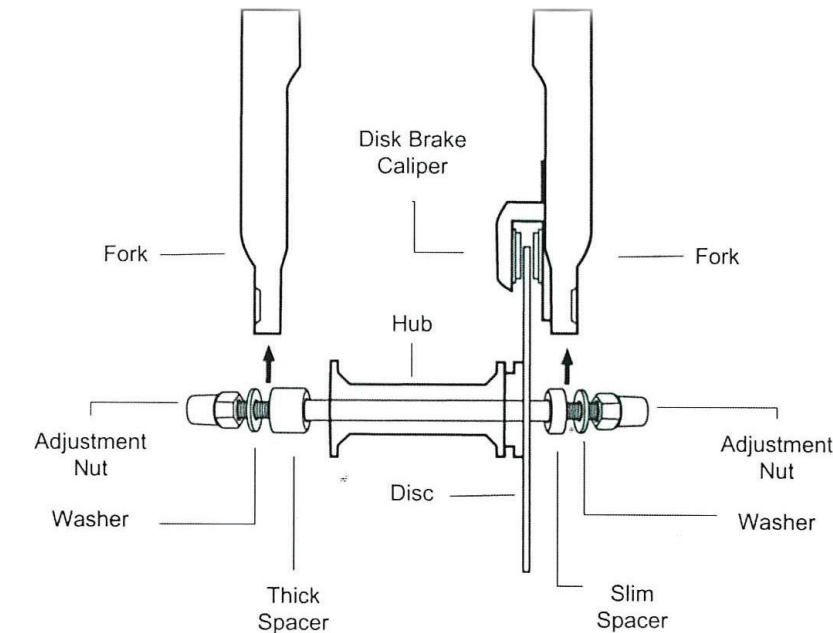

Fig. 11 - Installing the Front Wheel

4. Install and hand-tighten the two adjustment nuts equally. Use the supplied 15 mm socket and 15 mm wrench to finish tightening the adjustment nuts, being sure each nut is tightened equally on both sides.
5. The adjustment nuts must be very tight; be sure to retighten them after your first two rides.

INSTALLING THE HANDLEBARS

1. Point the headset towards the front of the bike.
2. Center the handlebar in the headset, taking care not to damage any wires.
3. Install the clamp and screws. Alternately tighten the screw side-to-side until secure.
4. Verify that the front tire lines up with the headset.
5. Verify that all headset items are tight.

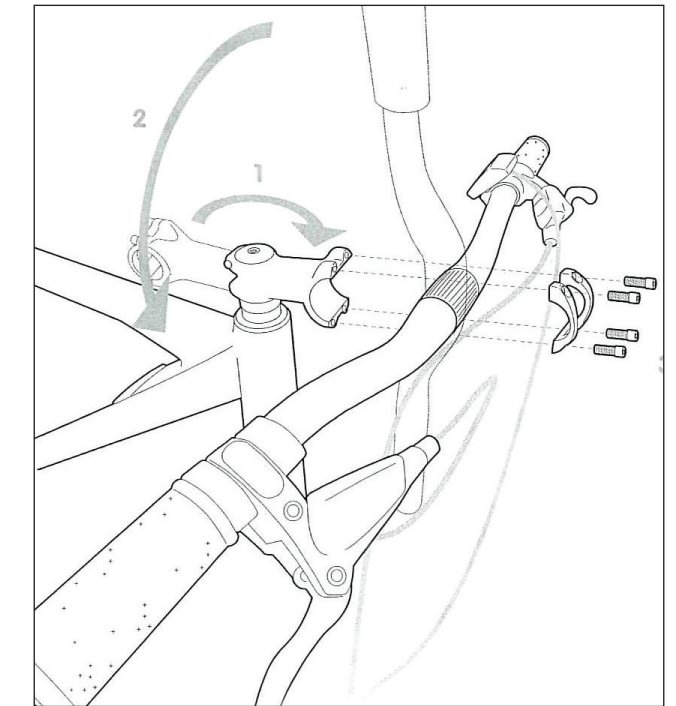

Fig. 12 - Installing the Handlebars

INSTALLING THE PEDALS

NOTICE

It's critical that the pedals are tightened firmly in the crank arm to prevent the pedals from loosening while riding, which will result in significant damage to the bike.

1. Identify the left and right markings on the pedals. Be sure to install the pedals on their respective side.
 - "L" is for the left pedal and is installed on the left crank arm.
 - "R" is for the right pedal and is installed on the right crank arm (chain side).

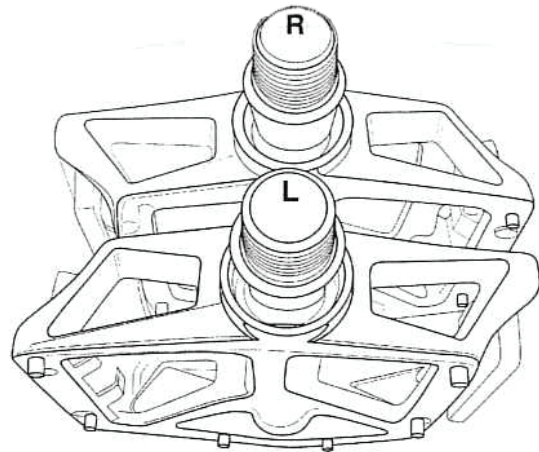

Fig. 13 - Left and Right Identification Marks

NOTE: Both pedals tighten toward the front of the e-bike.

2. While keeping the pedal horizontal, carefully hand-start the threads of the pedal into the crank arm.

3. Finish tightening the pedals using the supplied 15 mm wrench. The pedals must be very tight. Check and retighten the pedals after your first two rides.

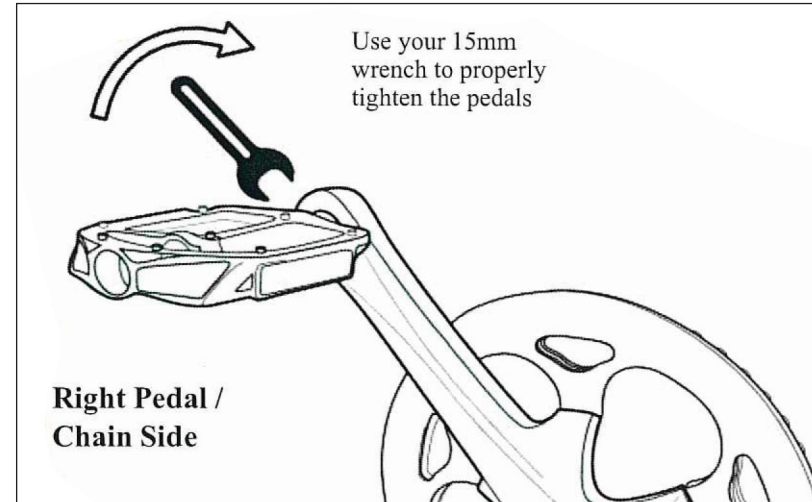

Fig. 14 - Installing Pedals

ADJUSTING RIDE COMFORT

WARNING



Changing suspension adjustment can change the handling and braking characteristics of your bicycle. After making an adjustment, test-ride the e-bike in a hazard-free area. Continue to adjust until you achieve the desired ride.

In most cases, the factory settings for the forks and rear shocks will not require adjustment. But, if you desire a softer or stiffer ride, adjust the forks and rear shocks as follows.

NOTE: Always adjust the forks and rear shocks in small increments. Adjust the forks and rear shocks at the same time.

To adjust the forks:

- Rotate the pre-load knob and compression knob counterclockwise to soften the ride. Rotate both knobs equally.
- Rotate the pre-load knob and compression knob clockwise to stiffen the ride. Rotate both knobs equally.

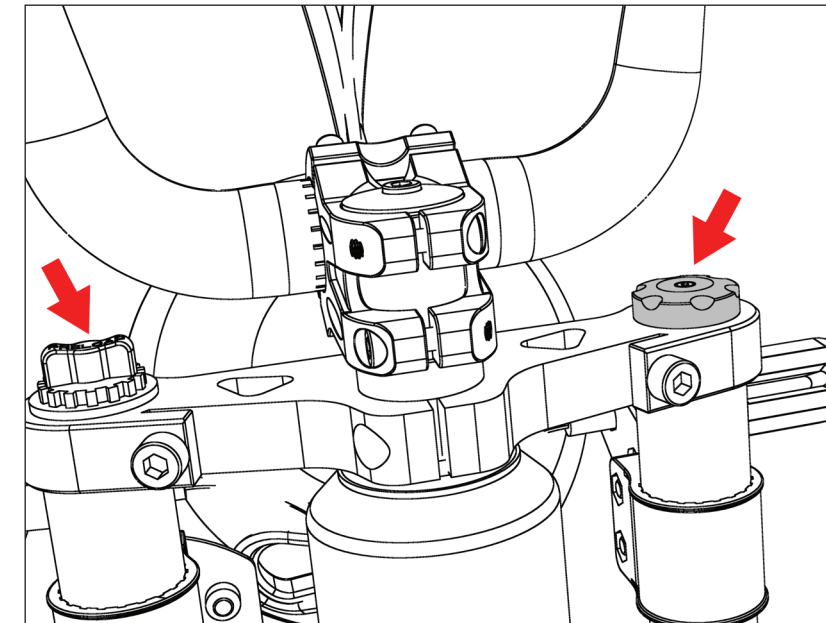

Fig. 15 - Adjusting the Forks/Fork Lockout

To adjust the rear shocks using a 5 mm hex wrench:

- Rotate the plug on both the left and right shocks counterclockwise to soften the ride. Rotate both plugs equally.
- Rotate the plug on both the left and right shocks clockwise to stiffen the ride. Rotate both plugs equally.

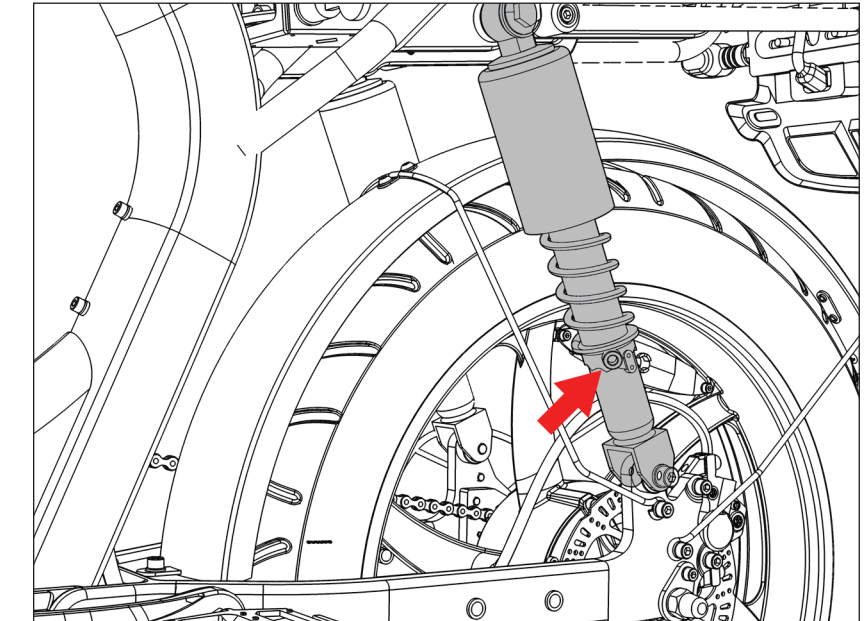

Fig. 16 - Adjusting the Rear Shocks

NOTE: Be sure all the items you installed are properly torqued, tightened and connected. If you have any questions, contact us. See "Contact Information" on page 1.

INITIAL RIDE

NOTE: Users can ride the e-bike like a normal bicycle with the power turned ON or OFF. However, the pedal assist and throttle will activate only if the power is turned ON.

We recommend that you ride your e-bike with the pedal assist off at first, to get familiar with the braking and gear shifting. Then, you can start testing the pedal assist levels incrementally to gain familiarity with the optimal settings for your riding style.

SAFETY CHECK BEFORE EACH RIDE

- The battery pack must be charged and properly installed.
- The display must turn on and function properly.
- The brakes must function properly.
- The tires must be inflated to the proper psi.
- The front and rear lights must work properly.
- The cable connections must be tight.

USING THE BRAKES

The e-bike is equipped with front and rear disc brakes. Their main function is to slow down or to stop the bicycle.

NOTE: Apply the rear brake before using the front brake in low-traction conditions.

- The brake on the front wheel is controlled by the lever on the left-hand side of the handlebar.
- The brake on the rear wheel is controlled by the lever on the right-hand side of the handlebar.
- The front brake provides the majority of the e-bike's stopping power.
- When slowing down on slippery surfaces, use the rear brake first before applying the front brake.
- A signal wire from each brake lever automatically turns off the motor when either brake is being used. This feature prevents undue wear on the electric motor and battery.

Your new brakes will undergo a "bedding-in" period and will wear down after the first 40-50 full stops. The brakes will reach 100% of their grip capacity after this period. Adjust the brake lever so that it adapts to the newly bedded-in brakes.

SHIFTING THE GEARS

The e-bike is equipped with a multi-speed gear set. Choose the lower gears when starting off from a stop or when riding slowly or climbing steep hills. Use higher gears when riding at speed. When using this bike as a normal bike, you will get used to using the gear settings that are most comfortable for your ride and trip. The gear shifter is located on the left side of the handlebar. Rotating the left handlebar grip will change the gear selection.

The gear shifting system and pedal assist control system are entirely independent; neither affects the other's performance.

PEDAL ASSIST CONTROL SYSTEM

The pedal assist control system also is known as a "pedelec." The pedal assist uses a combination of sensors that measure torque and cadence (force and speed) of your pedaling. This information transfers to the bike's controller, which generates the needed power. The control system can be used to maintain a constant level of pedal assist.

USING THE PEDAL ASSIST CONTROL SYSTEM

1. Press the battery power button to turn on the battery.

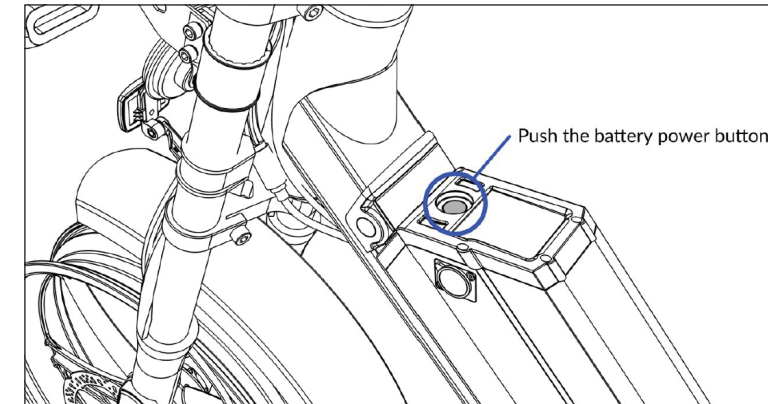

Fig. 17 - Battery Power Button

2. Insert the key and turn the ignition key switch. Be sure to have both feet off the pedals, as the torque sensor will calibrate when turning on. The LCD display panel will turn on and indicate the battery's charge level and selected pedal assist level.

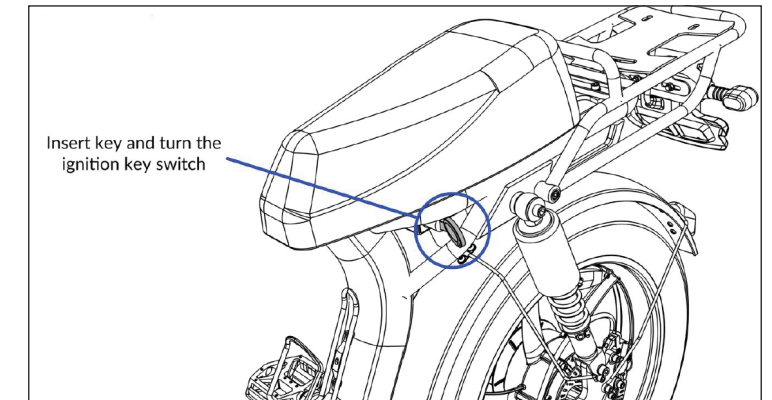

Fig. 18 - Ignition Key Switch

- Use the “+” or “-” buttons to select the desired pedal assist level.



Fig. 19 - Selecting Pedal Assist Level

The levels are between:

0	Throttle Operation Only
ECO	Battery Efficiency
1, 2, 3	Speed Ranges
S	Sport / Off-Road
R	Race Track Mode

The LCD will indicate the pedal assist level that you select. Once you start pedaling, the controller will make the motor turn accordingly. Use the ECO mode for your first test ride to get used to your e-bike.

The e-bike will now maintain a constant pedal assist until:

- The brakes are applied
- The “+” or “-” buttons are pressed to adjust the pedal assist level
- You stop pedaling
- The battery pack runs down completely

NOTE: If the battery pack level is low, we recommend selecting a lower assist level. Keep in mind that the battery management system can deactivate the pedal assist support to protect the battery pack level from getting too low. Be sure to charge the battery pack fully before each ride.

- To turn the headlight and taillight on or off, press and hold the “+” button for 3 seconds.
- Press and hold the controller power button to turn off the controller.
- Turn off the battery power button after each ride to avoid draining the battery pack.

THROTTLE OPERATION

Use the throttle and pedal assist at the same time or you can just use the throttle feature to ride the e-bike. The throttle control is located on the right-side handlebar next to the LCD screen.

To use the throttle feature:

- Turn on the battery and the controller. See “Using the Pedal Assist Control System” on page 17.

- Set the LCD to the desired setting. If you select “0,” the pedal assist control system is unavailable.
- Rotate the throttle control to increase the e-bike speed.

READING THE BATTERY PACK LEVEL

The LCD display indicates the battery pack’s voltage. The voltage can vary greatly depending on a variety of conditions.



Fig. 20 - Battery Level Indicator

The voltage will decrease temporarily when using the throttle and/or pedal assist. The voltage may drop when going uphill regardless of the charge state. This is normal operation. The voltage will be lower if the battery pack has been in a cold environment.

To more accurately read the battery pack’s charge state, let off the throttle. The display lights will stabilize after 1 second to indicate the battery pack’s level.

When the battery pack level is low and it reaches:

- 2 Bars - Recharge battery pack soon. Select a lower pedal assist level.
- 1 Bar - Stop using the throttle; recharge the battery pack.

UNDERSTANDING THE BATTERY PACK RANGE

All electric bicycles have a riding range that can vary greatly depending on riding style, terrain, tire pressure, temperature, payload and wind. After a few rides, you will get a sense of the electric bicycle’s range capability.

FACTORS THAT WILL DECREASE YOUR RANGE

- Rapid accelerations using the motor
- Uphill riding
- Heavy payloads
- Headwinds
- Underinflated tires
- Extreme hot or cold weather

HOW TO INCREASE YOUR RANGE

- Start by pedaling instead of only using the motor.
- Avoid rapidly accelerating using the throttle.
- Pedal to help the motor up steep hills. Use the gears.
- Reduce your average pedal assist level and pedal along with the motor.

- Reduce payload weight.
- Properly inflate the tires between 30-35 psi. Do not overinflate the tires.
- Coast to a stop and avoid rapid decelerations.

NOTICE
 If the battery pack power is low, choose a lower level of pedal assist if going on stops and hills. The sports mode will demand enough power to convince the battery pack that it is depleted, but you may still use a lower level of pedal assist.

NOTICE
 Riding downhill or pedaling when not using the throttle will not recharge the battery pack.

ADVANCED MATRIX DISPLAY OVERVIEW

The advanced matrix display acts as the dashboard for your e-bike. It has the ability to show the basic status of the electronics system such as speed, distance traveled and battery level.

It also has an “advanced mode” that can give additional information on how your electric vehicle is working. The display also lets you adjust a limited set of parameters to better customize the performance of your e-bike.

BUTTON OVERVIEW

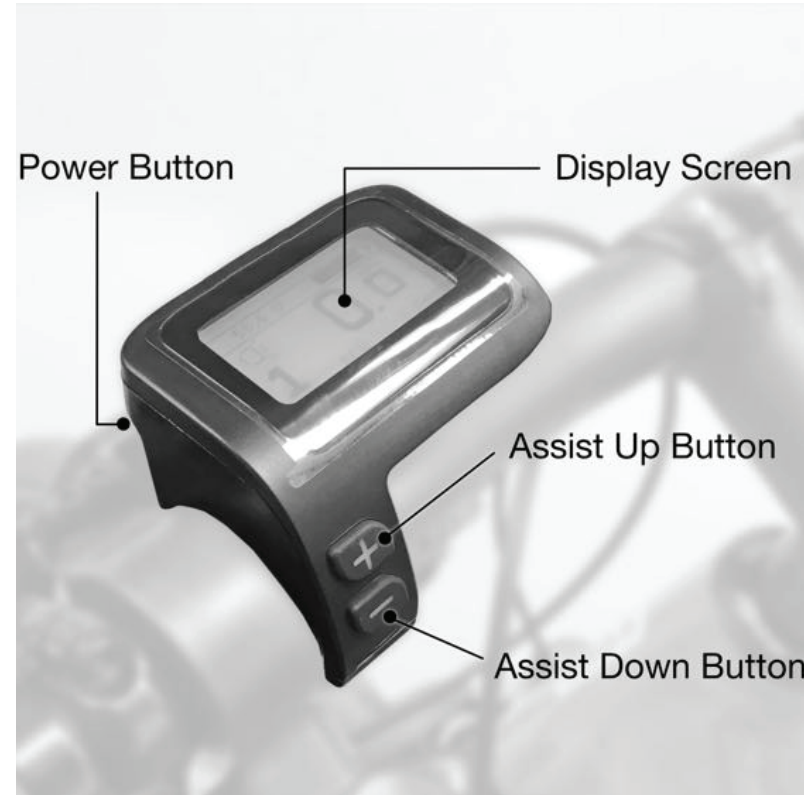

Fig. 21 - Buttons on the Advanced Matrix Display

Three buttons control the functions of the display.

Power Button: Located on the back side of the display

“Assist Up” Button: Located on the front face of the display

“Assist Down” Button: Located on the front face of the display

MAIN DISPLAY SCREEN OVERVIEW

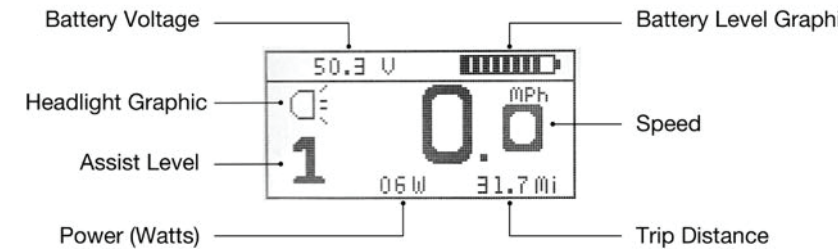

Fig. 22 - Advanced Matrix Display Screen

The main display shows several important metrics:

BATTERY VOLTAGE (VOLTS)

This is the voltage level of the battery. It is measured in volts (V).

HEADLIGHT GRAPHIC

The headlight graphic appears when you turn on the LED headlight. Turning on the headlight will also turn on the display’s backlight so the screen is visible in the dark.

ASSIST LEVEL

The assist level indicator displays which assist mode the bike is in.

The assist levels progress in the following order:



POWER (WATTS)

The power indicator shows how many watts the system is using in real time. When you turn the e-bike on, the bike uses about 4-6 watts even when not moving. This number will never be zero, as the system requires some small amount of power to operate.

BATTERY LEVEL GRAPHIC

The battery level graphic is a graphical representation of how much charge remains in the battery. More bars will appear in the graphic when the battery is charged. Less bars will appear when the battery is depleted.

SPEED (MPH OR KM/H)

The speed indicator shows the current speed that the e-bike is traveling. The speed can be shown in mph or km/h depending on which unit setting is used. The speed sensor picks up information from the rear wheel.

TRIP DISTANCE (MI OR KM)

The trip distance keeps track of how far the bike has traveled until the rider resets it.

TURNING THE E-BIKE ON AND OFF

HOW TO TURN THE E-BIKE ON

1. Press the battery power button to turn on the battery.

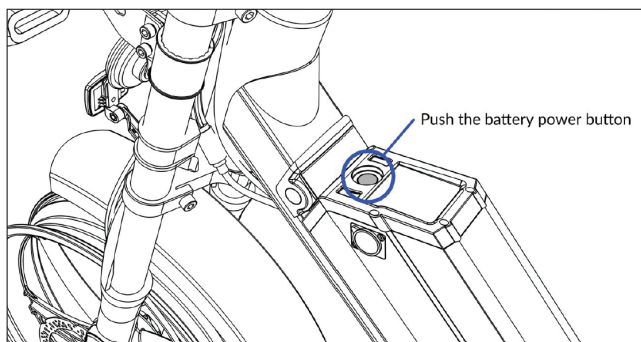

Fig. 23 - Battery Power Button

2. Insert the key and turn the ignition key switch. Be sure to have both feet off the pedals, as the torque sensor will calibrate when turning on. The LCD display panel will turn on and indicate the battery's charge level and selected pedal assist level.

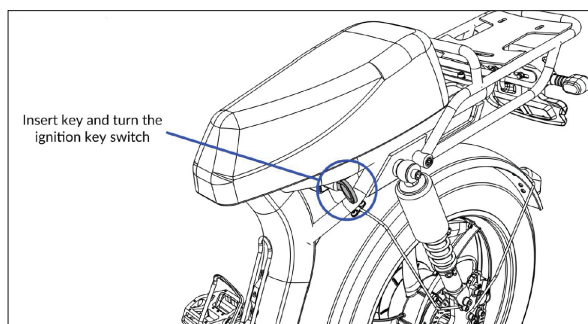

Fig. 24 - Ignition Key Switch

HOW TO TURN THE E-BIKE OFF

Turn the key and remove it from the ignition. Then press the battery power button and the bike will shut off.

AUTOMATIC SHUTOFF

The electronic system will also automatically shut down after a preset period of time. This duration can be adjusted in the setup menu.

ADJUSTING THE ASSIST LEVELS

HOW TO INCREASE THE ASSIST LEVELS

When the bike is on, push and release the “assist up” button. The assist will advance by one level until SPORT mode is reached.

HOW TO DECREASE THE ASSIST LEVELS

To decrease the assist level, push and release the “assist down” button. The assist will decrease by one level until ECO mode is reached.

The default assist setting is assist level 1. This will appear each time the e-bike is turned off and back on.

ACTIVATING THE HEADLIGHT

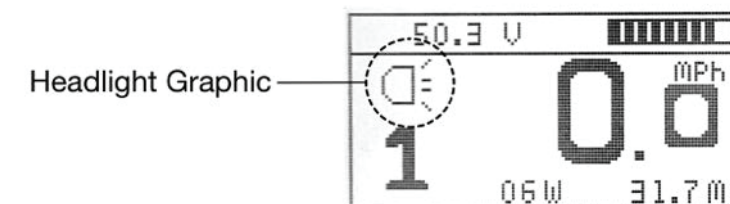

Fig. 25 - Headlight Graphic on the Main Display

TO TURN ON THE HALO LIGHT

After turning on your bike, the halo headlight will automatically turn on.

TO TURN OFF THE HALO LIGHT

Push and hold the “assist up” button for 2 seconds and the halo headlight will turn off.

TO TURN ON THE FULL HEADLIGHT

Use the combo switch located on the left side of the handlebar and switch the button up to turn it on.

TO TURN OFF THE FULL HEADLIGHT

Use the combo switch located on the left side of the handlebar and move the button down to turn it off.

ACTIVATING THE TURN SIGNALS

You can find the turn signal switch just below the headlight button. Toggle the switch left to turn on the left turn signals and right to turn on the right turn signals. To turn them off, position the switch back in the center.

ACTIVATING THE WALK MODE

When pushing the bike uphill, use the WALK mode. This mode will turn the motor at walking speed to assist you in moving the bike.

TO ACTIVATE THE WALK MODE

To activate the WALK mode, push and hold the “assist down” button. After 2 seconds the motor will begin to turn at walking speed.

TO STOP USING THE WALK MODE

To stop using the WALK mode, release the “assist down” button. The motor will stop turning and resume normal operation. Using either brake lever will also stop the WALK mode.

ACTIVATING THE CRUISE CONTROL FUNCTION

Use the cruise control feature to maintain a desired speed without using the throttle or pedal assist.

TO ACTIVATE THE CRUISE CONTROL FUNCTION

Use the throttle or pedal assist to reach your desired speed. Push and hold the “assist down” button for 2 seconds. When the “C” graphic appears, release the “assist down” button and the current speed will be maintained without the need to pedal or use the throttle. In CRUISE mode, the throttle is automatically modulated so that the desired speed is maintained.

To discontinue the use of the cruise control function, choose one of the following actions:

1. Use the brakes by squeezing the brake lever

2. Use the throttle
3. Push the “assist up” or “assist down” button

IMPORTANT NOTES ABOUT THE CRUISE CONTROL FUNCTION

- The cruise is considered a type of throttle and the maximum cruise controllable speed is 20 mph in accordance with regulations.
- If you set the cruise control speed above 20 mph, the cruise control speed will default to 20 mph. The speed will decrease until it reaches 20 mph.
- The pedal assist is still available when the cruise control is active. It may be possible to pedal the e-bike faster than the preset cruise speed. However, the cruise will automatically resume if the speed decreases to the preset cruise-controlled speed.
- If you need more power to achieve a preset speed (for example, when encountering resistance such as a hill or headwind) more power will automatically go to the motor to help maintain the preset speed.
- If the resistance is too much for the system to retain the preset speed, the resulting speed will be limited by the capability of the motor.

RESETTING THE TRIP COUNTER

The LCD display has a trip counter function to keep track of the distance of your ride over time. The Amp-hours (Ah) and Watt-hour (Wh) drawn from the battery pack are also linked to the trip counter data. You can reset the trip data to zero at any time.

TO RESET THE TRIP, AH, AND WH COUNTER TO ZERO

Push and hold both the power button and “assist down” button for 3 seconds, then release both buttons. The trip and Ah counter will reset to zero.

ACTIVATING THE ADVANCE DISPLAY SCREEN

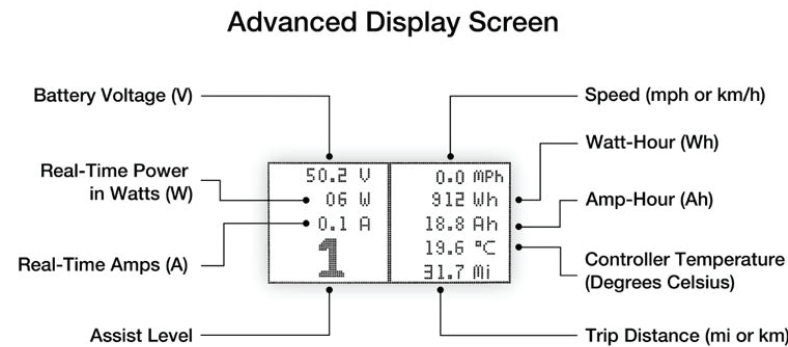

Fig. 26 - Data on the Advanced Display Screen

In some instances it is useful to see additional ride statistics. The display can be switched into the advanced display mode. This function will allow you to see expanded real-time data on one screen.

THIS DATA INCLUDES

Voltage, Power, Amps, Assist Level, Speed, Watt-hours, Amp-hours, Controller Temperature and Trip Distance

TO TOGGLE BETWEEN THE MAIN SCREEN AND THE ADVANCED DISPLAY SCREEN

Push the power button and the “assist up” button at the same time for 1 second. The display screen will change to the advanced mode.

NOTE: The default display is the standard screen. This is the first display that will appear when you turn on the e-bike.

UNDERSTANDING THE ADVANCED DISPLAY MODE

VOLTAGE

The voltage displayed is the voltage of the pack. When the battery is charged, the voltage will be higher (around 54V). When the battery pack is depleted, the voltage will be lower (around 43V). Voltage fluctuates when the battery is under load.

NOTE: The voltage display is only accurate to about +/- 0.3 Volts and should not be used for any scientific measurements.

AMPS

The amperage is the current flow through the wires. In this case we measure the current flow through the controller. The average will not be non-zero, as the system needs some small amount of current to operate. When the motor is under load, the Amp value will increase. The maximum value should be 20-22A on the nine-transistor controller.

NOTE: The Amperage display is only accurate to about +/- 1 A and should not be used for any scientific measurements.

POWER

Power is the Voltage x Amperage and appears in Watts. This is the power output at any moment of your e-bike. The more power used to propel the e-bike, the higher this value will be.

NOTE: Do not use the power display for any scientific measurements.

AMP-HOURS

The amp-hour figure measures the amount of current flowing out of the battery for a given hour. Reset the amp-hour and watt-hour value by resetting the trip counter.

WATT-HOURS

The watt-hour is the measurement of how many watts are sustained for a given hour. The watt-hour is the energy consumed by the system. You can get a good indication of how much energy remains inside the battery by subtracting the total watt-hours consumed by the total “Wh” available in the battery.

NOTE: Because there is a small error rate in the Amp and Voltage measurements, the Watt-hour value will also have some degree of error. Use the measurement for informational purposes and not for scientific measurements.

ASSIST LEVEL

The assist level indicator shows the assist level you are in at any given moment. It appears in both the advanced and the standard display modes.

SPEED

The speed indicator measures the speed of the bike. This value is measured from the motor's internal speed sensor. If you have changed to a new tire with a larger or smaller diameter than the included tire, you may need to manually adjust the wheel speed setting.

CONTROLLER TEMPERATURE

The controller temperature is measured by a temperature sensor mounted inside of the controller near the transistors. The temperature displays on the screen in Celsius. When the e-bike is under load, the controller's temperature will increase. The bike's performance will begin to decrease when the temperature exceeds 80 degrees Celsius.

TRIP DISTANCE

The trip distance counts up from zero. The distance is calculated by each rotation of the rear wheel. To reset the trip distance, refer to *"Resetting the Trip Counter" on page 24*.

ADJUSTING PARAMETERS IN THE SETUP MENU

Adjust some of the parameters to control the behavior of your e-bike.

TO ENTER THE SETTINGS MENU

Hold the "assist up" and "assist down" buttons for about 3 seconds, then release. You will now enter the setup menu. Here you can adjust a few settings to control the behavior of the e-bike.

AVAILABLE MENU OPTIONS

Unit	Power Off Delay
Speed Limit	NDW
Backlight	Torque
Wheel Size	Low Volts

NAVIGATING AND ENTERING A MENU SETTING

Use the "assist up" button and "assist down" button to navigate through the menu. When you have selected a parameter you wish to adjust, push the power button once and you will enter that setting.

You will then have the ability to adjust this setting's value with the "assist up" and "assist down" buttons. When you have adjusted the setting to your preference, push the power button to exit that setting. Continue pressing and releasing the power button until you have exited out of the setup menu and return to the main screen.

The parameters you have adjusted will not be programmed into the system. Check to see if the settings meet your needs with a short test-ride. If the settings need adjustment, follow the setup instructions again.

UNIT

The unit setting allows you to select between miles per hour (mph) and kilometers per hour (kmh).

- mph: miles per hour
- km/h: kilometers per hour

SPEED LIMIT

The speed limit setting allows you to set the speed limit of the bike.

The bike will accelerate up to the maximum speed specified in this setting.

CLASSIFICATION	SET POWER LIMIT	SET PEDAL ASSIST	THROTTLE OPERATION
USA Class 1 / 750W	Set NDW to 4	20 mph	Not allowed
USA Class 2 / 750W*	Set NDW to 4	20 mph (32 km/h)	20 mph (32 km/h)
USA Class 3 / 750W	Set NDW to 4	28 mph (45 km/h)	20 mph (32 km/h)
Europe 250W / 25 km/h	Set NDW to 1	15.5 mph (25 km/h)	Not Allowed
Europe S-Pedelec / 45 km/h	Set NDW to 4	28 mph (45 km/h)	Not Allowed
Off-road mode**	Set NDW to 5	30+ mph	30 mph (48.2 km/h)

**default configuration **please refer to local laws & regulations before using*

BACKLIGHT

Set the brightness of the backlight to the desired level.

WHEEL SIZE

Set the circumference of the tire according to the particular wheel specification.

The wheel circumference is set in mm (millimeters).

"POWER OFF" DELAY

The "power off" delay timer lets you set the duration that bike will remain inactive before the electronics system will automatically shut down to conserve power.

NDW

The NDW is the pedal assist level limiter. In the default configuration pedal assist has 5 modes:

ECO, 1, 2, 3, and SPORT

Adjust the maximum pedal assist level that can be selected by changing the value of the NDW setting.

NDW SETTING

- 1 - The maximum assist level that can be selected is assist level 1.
- 2 - The maximum assist level that can be selected is assist level 2.
- 3 - The maximum assist level that can be selected is assist level 3.
- 4 - The maximum assist level that can be selected is assist level SPORT.
- 5 - The maximum assist level that can be selected is assist level RACE.

TORQUE

The pedal assist system provides you with motor assistance when you pedal. Choose if you want to use the torque sensor

measurement for the pedal assist. The torque sensor is on by default. In normal operation, both the torque sensor and cadence sensor measurements will be used to determine the pedal assist support level.

ON: The torque sensor will activate and the pedal assist will factor in torque and cadence measurements to determine the pedal assist support level.

OFF: The torque sensor will be turned off and only the cadence sensor measurement will be used to determine the pedal assist support level.

LOW VOLTS

The low voltage setting controls how deeply the battery discharges. The lower this setting, the lower the battery discharges.

Studies have shown that avoiding a deep discharge state can significantly increase battery life. The “low volts” setting will determine a limit to the lowest voltage before the battery pack discharges.

When the motor draws power from the battery pack, the voltage of the battery will decrease. When the voltage further decreases and reaches the preset limits, the control system will automatically limit power so the voltage never decreases below this pre-set limit.

When the nominal voltage of the pack approaches the low voltage limits that have been set, very little power will be available to propel the e-bike. You must recharge the battery to regain full power.

ERROR CODES

The electronics system has some ability to self-diagnose and report a limited set of faults. The faults will appear on the screen as error codes. The chart below explains the meaning of each error code.

ADVANCED MATRIX DISPLAY - ERROR CODE CHART		
Error Code	Error	Notes
4	Open Throttle Fault	Throttle has not returned to the start position on start-up. Check to see if the throttle can return to the start position or if there is something blocking the throttle unit.
5	Throttle Fault	Throttle may be damaged. Check the throttle or throttle cable for damage.
6	Low Voltage Protection	The battery voltage is too low to operate. Incorrect battery was used on the bike. The battery is in sleep mode or not functioning correctly.
7	Over Voltage Protection	The battery voltage is too high to operate. Incorrect battery was used on the bike. Check to be sure that the correct battery is being used on the bike.
8	Motor Hall Signal Fault	At least one of the motor's hall sensor wires have been disconnected or damaged. Disconnect and reconnect the motor cable.
9	Motor Phase Line Fault	At least one of the motor's phase wires has been disconnected or damaged.
10	High Temperature Fault	The controller has reached the highest allowable temperature. Allow the controller to cool down before using the e-bike again.
11	Temperature Sensor Fault	The controller's temperature sensor has become disconnected or damaged. Contact technical support.
12	Current Sensor Fault	The controller's current sensor has become disconnected or damaged. Contact technical support.
21	Speed Sensor Fault	The speed sensor has become disconnected or damaged. Contact technical support.
30	Communication Fault	Poor connection between the controller and the display. Check all cable connectors. Check for corrosion damage.

BATTERY

NOTICE

Failure to properly charge, store or use the battery will void the warranty.

REMOVING THE BATTERY PACK

You can remove the battery pack from the bike. Remove the battery pack when storing or transporting the e-bike.

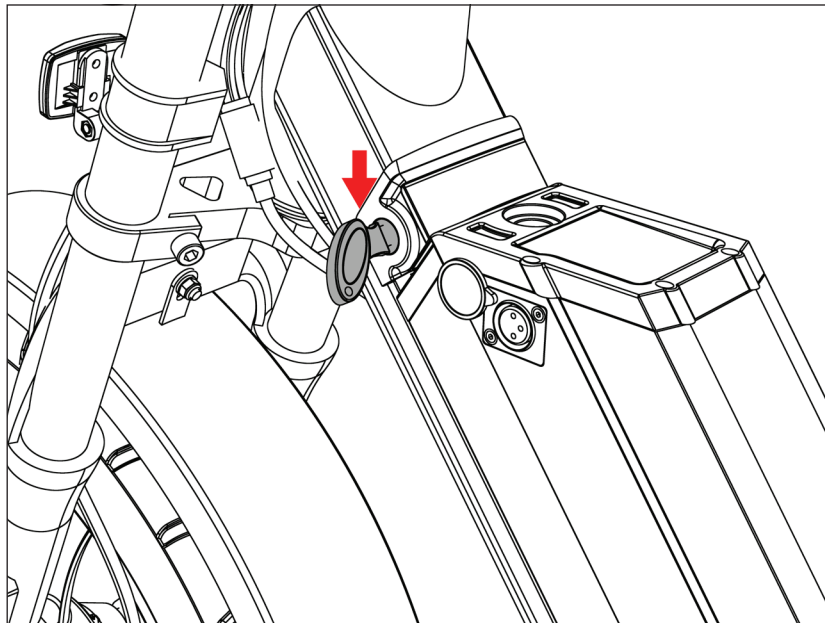

Fig. 27 - Removing Battery Pack

1. Turn off the bicycle.
2. Stand on the left side of the bicycle. Locate the keyhole on the frame near the top of the battery pack.

3. Insert the key into the battery pack lock keyhole.
4. Turn the key clockwise and hold.
5. Pull the upper portion of the battery pack toward you.
6. Let go of the key from the battery pack lock.
7. Pivot the battery pack sideways and lift it away from the bike.

CHARGING THE BATTERY PACK

The charger can become warm during charging.

 **WARNING**

Read and understand all instructions. Failure to follow all instructions listed below could result in death or serious personal injury.



- Use only the charger supplied with the bicycle. Do not charge the battery pack with any charger that is not supplied or approved to charge the bike.
- Do not place anything over the charger while it is charging.
- Do not use the charger in damp or wet locations.
- Do not cover the body of the charger when charging.
- Do not drop the charger or subject it to high vibration. Do not use a charger that has been dropped.
- Do not short-circuit the battery pack's terminals.

- Do not charge the battery pack if the temperature is over 140°F (60°C).
- Do not disassemble the battery pack.
- Do not submerge the battery pack in liquid or use it in wet areas.
- Do not place the battery pack near fire or heat.
- Do not expose the battery pack to freezing temperatures for an extended period. Do not charge a frozen battery pack. Allow it to reach room temperature.

The e-bike features a high-capacity lithium ion rechargeable battery pack. The lithium battery pack does not have a “memory effect” associated with older battery technologies. It is highly recommended you charge the battery pack after every ride, even if the battery pack is only lightly used.

An onboard circuit prevents the battery pack from overcharging. The battery pack can achieve 500-700 full charge cycles. As the battery pack receives more charge cycles, the capacity will decrease. Charging a partially discharged battery pack is not considered a full charge cycle.

NOTICE

Recharge the battery pack at least once every month. A battery pack left unused for several months may result in permanent capacity loss.

Cold environments temporarily reduce the battery pack's capacity. Avoid using the electric bicycle in very hot weather. Store the e-bike in a sheltered place.

Fully charge the battery pack before your first use. The charger

included with the e-bike recognizes the battery pack's initial charge and will automatically cease charging when the battery pack is fully charged. Always charge the battery pack before a long trip.

- Be sure the e-bike is powered off.
- Be sure to use the proper 48 VDC or 52 VDC charging profile if using the Cycle Satiator® charger.
- The battery pack can be charged while connected to the e-bike or while removed from the e-bike. (See “Removing the Battery Pack” on page 30.)

ONBOARD CHARGING

1. Stand on the left side and locate the charge port dust cover on the top of the battery pack.
2. Rotate the dust cover to expose the DC charge port.

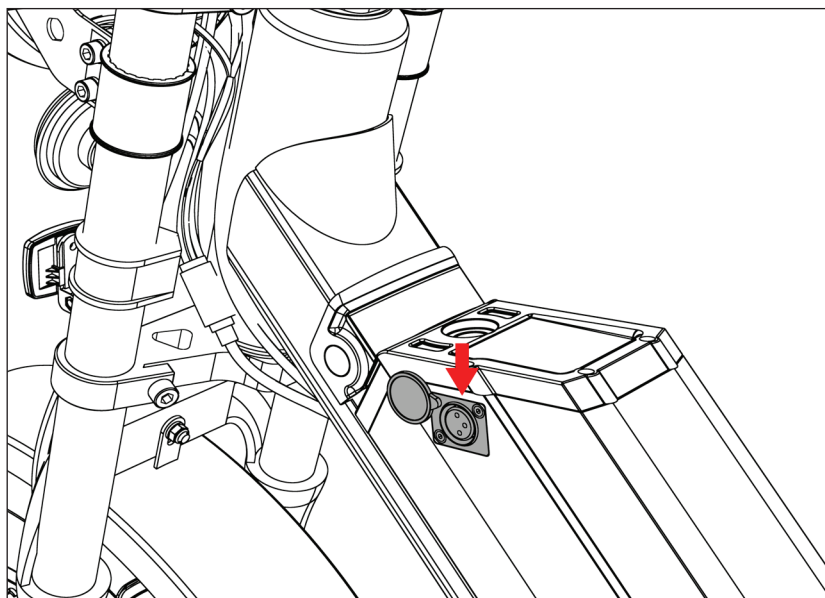

Fig. 28 - Charge Port

3. Carefully plug the charger into the charge port.
4. Connect the AC power cable into the charger and plug the cable into the power outlet. The charger will automatically start charging the battery pack.
5. When the charger is charging the battery pack, the indicator LED will turn red. When the battery pack is fully charged, the light will turn green and the battery will automatically stop charging. Charging takes 1-8 hours,

depending on battery size and initial charge level. (See “Reading the Battery Pack Level” on page 19.)

6. Disconnect the charger from the wall.
7. Remove the charger plug from the DC charge port. Rotate the dust cover to protect the port.

HYDRAULIC BRAKES

There are several components that make up your braking system. The hydraulic part needs to be inspected and serviced to check for wear and tear. If the hydraulic brakes are worn, replacement will be needed. When a replacement is needed varies by amount of time riding, mileage, riding style and location.

We recommend inspecting your brakes before every ride.

Notice: If there appears to be any issue with your braking system (or any other item) do not use your bike and contact our Support Team or visit an authorized mechanic.

MINERAL OIL CUPS

Have a trained mechanic service the mineral oil cups on the handlebars.

BASIC TROUBLESHOOTING

SYMPTOMS	POSSIBLE CAUSES	SOLUTIONS
Throttle and pedal assist not working	<ul style="list-style-type: none"> • Battery off • Battery installation • LCD display not on • Discharged battery • Brake sensors engaged 	<ul style="list-style-type: none"> • Turn on battery • Reseat battery • Turn on LCD display • Charge battery • Inspect brake lever
Reduced speed	<ul style="list-style-type: none"> • Low battery power 	<ul style="list-style-type: none"> • Charge battery
Reduced battery range	<ul style="list-style-type: none"> • Low battery power • Low tire pressure • Heavy load on bike • Driving on rough terrain • Using throttle only 	<ul style="list-style-type: none"> • Charge battery • Inspect tire • Adjust bike load • Adjust route • Include pedal assist use
Battery does not charge	<ul style="list-style-type: none"> • Charger not properly connected • Battery temperature • Damaged charger • Issue with battery 	<ul style="list-style-type: none"> • Inspect connections • Visit our website for best practices • Replace charger • Contact Support Team
E-bike making strange noises	<ul style="list-style-type: none"> • Loose hardware • Issue on drivetrain • Issue with motor 	<ul style="list-style-type: none"> • Tune-up and inspection needed • Maintenance needed • Contact Support Team

For additional troubleshooting, go to our FAQ section on our website at: <https://support.juicedbikes.com/hc/en-us/sections/360002709492-Troubleshooting>

Or contact us at: <https://support.juicedbikes.com/hc/en-us/requests/new>

JUICED BIKES WARRANTY

<https://www.juicedbikes.com/pages/warranty>

At Juiced Bikes, we take great pride in the quality and durability of our products. We're confident that you will be impressed as well, and we stand behind all of our products.

Every e-vehicle we sell is covered by a limited warranty against manufacturing defects subject to the terms below:

COVERED PRODUCTS

- This warranty applies only to products, parts, and components (hereafter PRODUCTS) that have been manufactured, assembled, or sold in new condition by Juiced Bikes/Juiced Riders, Inc. (hereafter, JUICED).
- This warranty applies only to replacement/repair of PRODUCTS in case of a manufacturing flaw in materials or workmanship, in accordance with the Scope of Warranty Service, and subject to any and all exclusions, limitations, and procedures explained below.
- This warranty is **not transferable in any way** and may not be exercised by anyone other than the original retail buyer (hereafter BUYER) of the PRODUCTS, only if the BUYER has retained constant ownership of the PRODUCTS since their original purchase of the PRODUCTS and only to PRODUCTS purchased in **new condition** either:

WARRANTY PERIOD

- Battery packs are covered for a period of 1 year on manufacturer defects only. We DO NOT cover wear and

tear or USAGE on your battery.

- Other electronic components are covered under warranty for a period of 1 year from the date of purchase.
- Bicycle frames are covered by a 1-year warranty against manufacturing defects.
- Mechanical components are covered by a 1-year warranty against manufacturing defects.
- For all PRODUCTS, this warranty expires 1 year from the date the PRODUCTS were delivered to the BUYER unless excluded from warranty or otherwise voided from coverage under warranty.
- New Bike Guarantee - we offer full replacement of defective parts with free shipping within the first 30 days of your bike order. After 30 days the customer is responsible for all return shipment costs to Juiced. Juiced Bikes will pay for shipping to the customer only.

WARRANTY EXCLUSIONS

The intent of this warranty is to ensure that the BUYER of any new PRODUCTS sold by JUICED or any JUICED product sold by an authorized JUICED dealer will receive a quality product, free of manufacturing flaws. This warranty should not be considered to be an insurance policy against any damage occurring after the products are received, nor as explicit or implicit acceptance by JUICED of responsibility for the consequences resulting from the failure of any PRODUCTS, irrespective of whether the failure itself is covered by this warranty.

In addition, the following situations are excluded from this warranty or lead to exclusion from this warranty:

- Warranty claims not made in accordance with Warranty Claims Process (explained below)
- PRODUCTS with technical alterations that have been made without the approval of the manufacturer
- PRODUCTS with alterations to or additions to which use incompatible or non-original parts
- Damage to or failure of PRODUCTS resulting from weather or ordinary wear and tear.
- Theft, robbery, vandalism, intentional damage, damage resulting from bumps and scrapes after possession of the PRODUCTS has been transferred to the BUYER.
- PRODUCTS that haven't been manufactured or sold by JUICED
- Incidental/consequential damage or injury
- PRODUCTS that have been used or transported inappropriately or improperly (e.g., by loading a JUICED bike above the maximum weight recommendation)
- PRODUCTS with damage resulting from improper maintenance (e.g., storing battery fully discharged over the winter)
- Any electrical component that has been opened, altered, partially disassembled, or completely disassembled except by JUICED or an authorized JUICED dealer.
- Any PRODUCTS that have been disassembled in a manner

not authorized by JUICED or that have had repairs attempted by anyone not authorized by JUICED.

- PRODUCTS that have been damaged due to improper adjustment or worn components
- PRODUCTS with damage resulting from an accident
- PRODUCTS that have been lent, leased, or rented commercially
- Bicycles not registered with JUICED by the BUYER within **60 days of delivery/sale**
- Warranty shall not apply to PRODUCTS and/or situations in accordance with the terms of a specific sale (e.g., scratches and dents to scratch & dent discounted merchandise)
- Cleaning of any PRODUCTS
- PRODUCTS that were not purchased by BUYER in new condition
- JUICED BIKES will not pay for any third-party service or part replacement unless agreed upon prior to the fix.
- JUICED BIKES will not pay for return shipping on any damaged or defective product or component.
- JUICED BIKES will not cover any damage resulting in the use of a third-party battery charger.
- JUICED BIKES will not cover any damage that may occur during shipping if the owner sets up their own shipping option or if the bike is shipped using a freight forwarder or similar service.

- International Orders, our warranty is only good in the U.S.

THE SCOPE OF WARRANTY SERVICE

In case of a warranty claim within the warranty period for a non-excluded situation JUICED agrees to repair or replace the failed warranted PRODUCTS with equivalent parts/accessories/components at the discretion of JUICED, by JUICED, an authorized JUICED dealer, or by a third-party with the approval of JUICED. Replacement parts may not be identical to those being replaced.

Any additional non-warranty work done concurrently with a warranty repair/replacement will be subject to ordinary parts/labor fees. This includes anything not included by the warranty as well as anything excluded from the warranty.

No service, repair, or parts replacement provided under warranty will extend the original warranty period.

Warranty Claims Process

- Register your Bike/Skateboard/Scooter within 60 days of purchase. Other products do not require registration
- If you suspect that any part/component is defective, **do not attempt to repair or replace it yourself or to have it repaired or replaced before contacting JUICED**—doing so may invalidate your warranty and may cause additional damage, not necessarily limited to the PRODUCTS in question, and may also create the risk of injury.
- Contact JUICED via email to submit your warranty claim:

support@juicedbikes.com. Juiced Bikes will not replace any part without first seeing photos or video of the damaged part.

- We will contact you to make plans for inspection and any warranty repairs
- All claims to this warranty must be made through Juiced Bikes. Proof of purchase may be required with any warranty request. Before making a warranty claim, we suggest that you contact our Technical Support team at support@juicedbikes.com as there may be a simple fix for your problem. Valid warranty claims will be processed through Juiced Bikes within one year of initial purchase.

SEVERABILITY

The invalidity or unenforceability of any provisions of this Agreement shall not affect the validity or enforceability of any other provision of this Agreement, which shall remain in full force and effect. Any provision of this agreement deemed to be invalid or unenforceable shall be interpreted, unless prohibited by law, in accordance with the provision's intent and in consideration of applicable laws and corresponding industry standards.

SHIPPING DAMAGE CLAIMS

IMMEDIATELY inspect your product(s) for damage. Freight damage claims are extremely time sensitive. We will not accept freight damage claims later than 14 days from receipt of the product. Note any damage to your product(s) on the Bill of Lading before you and the driver sign-off on the shipment. Take pictures of any damage that is found, and date the images when

possible. Keep all packaging and paperwork until the inspection process is complete. Whenever possible, report damage claims within 10 days of delivery to a Juiced Bikes' customer support representative. Please contact our Customer Support team for return/replacement instructions at: support@juicedbikes.com | (888) 303-8889 ext 2.

We stand behind the warranty of our products and can assure you we learn every lesson along the way, bringing it into our services.

Service and support exist because in the real world, there are a lot of variables that will interact with your bike. So, we want you to be sure that we are here to help you and help you have the best riding experience. Your help will always be appreciated. We value your time and attention immensely.

Our goal is to be the friend you call when you have a doubt, or when you need to move the way you desire. Always feel free to read our materials and to reach out with any questions.

Register your Juiced Bike on our website:

<https://www.juicedbikes.com/pages/registration>

Model Names: HyperScorpion & HyperScorpion Express

Please note each bike has its own serial number which is located on the bike. The registration link provided shows where the serial number is located.



JUICED BIKES
1669 BRANDYWINE AVE STE A
CHULA VISTA, CA 91911
888-303-8889
JUICEDBIKES.COM