

The D2xS1 alarm horn is CE marked for compliance with the European Explosive Atmospheres Directive 94/9/EC and the European EMC Directive 89/336/EEC

1) Introduction

The D2xS1 is an ATEX, IECEx and UL certified alarm horn which produces a loud warning signal in a hazardous area. Sixty-Four first stage alarm sounds can be selected by internal switches and each one can be externally changed to a second, third or fourth stage alarm sound. The alarm horn may be used for Gas applications in Zone 2 / Class I Zone 2 / Class I, Division 2 as well as for Dust applications in Zone 22 / Class II Zone 22 / Class II Division 2 / Class III Division 1 & 2. A D2xS1 combined alarm horn & strobe is also available. The 24Vdc version is also listed for use in fire alarm systems –public mode.

2) Warnings

SUITABLE FOR USE IN CLASS II, DIVISION 2, GROUPS A, B, C AND D HAZARDOUS LOCATIONS
 SUITABLE FOR USE IN CLASS II, DIVISION 2, GROUPS E, F AND G HAZARDOUS LOCATIONS
 WARNING: DO NOT OPEN WHEN EXPLOSIVE ATMOSPHERE IS PRESENT
 WARNING – EXPLOSION HAZARD – SUBSTITUTION OF ANY COMPONENT MAY IMPAIR SUITABILITY FOR CLASS I, DIVISION 2.
 WARNING – EXPLOSION HAZARD – SUBSTITUTION OF ANY COMPONENTS MAY IMPAIR SUITABILITY FOR CLASS II, DIVISION 2.
 POTENTIAL ELECTROSTATIC CHARGING HAZARD – CLEAN ONLY WITH A DAMP CLOTH
 USE HEAT RESISTANT CABLES AND CABLE GLANDS (RATED 90°C OR HIGHER)
 EXPLOSION HAZARD. DO NOT REMOVE OR REPLACE LAMPS, FUSES OR PLUG-IN MODULES UNLESS POWER HAS BEEN DISCONNECTED OR THE AREA IS KNOWN TO BE FREE OF IGNITIBLE CONCENTRATIONS OF FLAMMABLE GASES OR VAPORS.
 EXPLOSION HAZARD. DO NOT DISCONNECT WHILE THE CIRCUIT IS LIVE OR UNLESS THE AREA IS KNOWN TO BE FREE OF IGNITIBLE CONCENTRATIONS.

3) Ratings and Markings

3.1 ATEX / IECEx certification

The D2xS1 alarm horn complies with the following standards:-

EN60079-0:2012 / IEC60079-0: ed. 6.0 (2011-06)
 EN60079-15:2010 / IEC60079-15: ed. 4.0 (2010-01)
 EN60079-31:2009 / IEC60079-31:2009 ed. 1.0 (corr. 1 2009)

The Type Examination Certificate DEMKO 14ATEX4786493904X / IECEx ULD14.0004X has been issued by UL. This confirms compliance with the European ATEX Directive 94/9/EC for Group II, Category 3G/D equipment. The alarm horn carries the Community Mark and subject to local codes of practice, may be installed in any of the EEA member countries. This instruction sheet describes installations which conform to the current issue of EN60079-14/IEC60079-14 Electrical Installation in Hazardous Areas; EN60079-10-1 / IEC 60079-10-1 Explosive Atmospheres - Classification of Areas. Explosive Gas Atmospheres; EN60079-10-2 / IEC 60079-10-2 Explosive Atmospheres - Classification of Areas. Explosive Dust Atmospheres. When designing systems for installation outside the UK, the local Code of Practice should be consulted.

The D2X Alarm horn is rated as follows:

	II 3G	Ex nA IIC T4 Gc (Ta -40°C to +50°C)
	II 3D	Ex tc IIIC T90°C Dc (Ta -40°C to +50°C)

CE Marking



Zones, Gas / Dust Groups and Temperature Classification

When connected to an approved system the D2X alarm horn may be installed in:

- | | |
|---------|--|
| Zone 2 | explosive gas air mixture not likely to occur in normal operation, and if it does, it will only exist for a short time. |
| Zone 22 | explosive dust air mixture not likely to occur in normal operation, and if it does, it will only exist for a short time. |

May be used with gases in groups:

- | | |
|-----------|----------------------|
| Group IIA | propane |
| Group IIB | ethylene |
| Group IIC | hydrogen / acetylene |

Having a temperature classification (for Gas applications) of:

- | | |
|----|-------|
| T1 | 450°C |
| T2 | 300°C |
| T3 | 200°C |
| T4 | 135°C |

May be used with Dust types:

- | | |
|------------|---------------------|
| Group IIIA | combustible flyings |
| Group IIIB | non-conductive dust |
| Group IIIC | conductive dust |

Maximum Surface Temperature for Dust Applications:

90°C

3.2 Class / Zone ratings US

The D2xS1 alarm horn complies with the following standards:

ANSI/UL 60079-0-2013
ANSI/UL60079-15-2013
ISA60079-31-2013

The D2X Alarm horn is rated as follows:

Class I, Zone 2 AEx nA IIC T4 Gc (Ta -40°C to +50°C)
Zone 22 AEx tc IIIC T90°C Dc (Ta -40°C to +50°C)

Installation must be carried out in compliance with the National Electric Code.

3.3 Class / Zone ratings Canada

The D2xS1 alarm horn complies with the following standards:

CAN/CSA C22.2 No. 60079-0:11
CAN/CSA C22.2 No. 60079-15:12
CAN/CSA C22.2 No. 60079-31:12

The D2XS1 Alarm horn is rated as follows:

Ex nA IIC T4 Gc X (Ta -40°C to +50°C)
Ex tc IIIC T90°C Dc (Ta -40°C to +50°C)
Class II Div 2 EFG T5 (Ta -40°C to +50°C)

Installation must be carried out in compliance with the Canadian Electric Code

3.4 Class / Division Ratings for US and Canada

The D2xS1 alarm horn complies with the following standards:-

ANSI/ISA 12.12.01-2013
CSA C22.2 No. 213-M1987
CSA C22.2 No. 157-92:2006

The D2XS1 Alarm horn is rated as follows:

Class I Div 2	ABCD T3C	Ta -40°C to +70°C
Class I Div 2	ABCD T4	Ta -40°C to +65°C
Class I Div 2	ABCD T4A	Ta -40°C to +50°C
Class II Div 2	FG T5	Ta -40°C to +50°C
Class II Div 2	FG T6	Ta -40°C to +45°C
Class III Div 1 & 2		Ta -40°C to +50°C

Installation must be carried out in compliance with the National Electric Code / Canadian Electric Code

3.5 Ambient Temperature Range:

-40°C to +70°C (Class I Div 2 only)
-40°C to +50°C

3.6 Ingress Protection Ratings

The product is rated for ingress Protection as follows:

IP rating per EN60529:	IP66
Type rating per UL50E / NEMA250:	4 / 4X / 3R / 13

To maintain the ingress protection rating, the two off M20 cable entries must be fitted with suitably rated, certified cable entry and/or blanking devices during installation.

3.7 Electrical Ratings

Part No.	Nominal Voltage	Nominal Current	Voltage Range	Max Current
D2xS1DC024	24Vdc	313mA	10-30Vdc	313mA @ 24Vdc
D2xS1DC048	48Vdc	181mA	38-58Vdc	218mA @ 48Vdc
D2xS1AC115	115Vac	89mA	115Vac +/-10% 60Hz	91mA @ 126.5Vac
D2xS1AC230	230Vac	52mA	230Vac +/-10% 50Hz	72mA @ 253Vac

3.8 Fire Alarm Ratings

The following models are approved for use as audible signal appliances for fire alarm use – public mode and produce a sound pressure level above 75dB(A) at 10 feet:

D2xS1DC024

For public mode fire alarm use the temporal pattern tone No. 12 as per the tone table provided in these instructions must be selected. This tone produces a sound pressure level of 103.6 dB(A) at 10 feet.

4) Special Conditions for Safe Use

Special Condition for safe Use as stated on the Type Examination Certificate DEMKO 14 ATEX 4786493904X / CoC IECEx ULD 14.0004X:

End user shall adhere to the manufacturer's installation and instruction when performing housekeeping to avoid the potential for hazardous electrostatic charger during cleaning, by using a damp cloth.

The D2xC1 is not to be mounted with the horn facing upwards
The equipment shall only be used in end use with appropriately certified cable entry devices and blanking plugs

4.1 Installation

The product must only be installed by suitably qualified personnel in accordance with the latest issues of the relevant standards.

The installation of the units must also be in accordance with any local codes that may apply and should only be carried out by a competent electrical engineer who has the necessary training.

The alarm horn is not to be mounted with the horn facing upwards.

The equipment has not been assessed as a safety-related device (as referred to by Directive 94/9/EC Annex II, clause 1.5).

The cable entry temperature may exceed +70°C / the cable branching point may exceed 80°C. Therefore suitable heat resisting cables and cable glands must be used, with a rated service temperature of at least 90°C.

To maintain the ingress protection rating and mode of protection, the M20 x 1.5 cable entries must be fitted with suitably rated, certified cable glands and/or suitably rated, certified blanking devices during installation. If a high IP

(Ingress Protection) rating is required then a suitable sealing washer must be fitted under the cable gland. For use in explosive gas atmospheres a minimum ingress protection rating of IP54 must be maintained. For use in explosive dust atmospheres a minimum ingress protection rating of IP64 must be maintained.

Only the front cover is to be used for access to the enclosure for installation, service and maintenance. Once the product is opened, the Type Rating cannot be maintained anymore unless a full verification of the gasket material is done and there is no damage.

Connections are to be made into the terminal blocks using solid or stranded wire, sizes 0.5-2.5mm² / AWG 20-14. Wire insulation needs to be stripped 6-7mm. Wires may be fitted securely with crimped ferrules. Terminal screws need to be tightened down with a tightening torque of 0.56 Nm / 5 Lb-in. Internal earthing connections should be made to the Internal earth terminal on the PCBA. The earth conductor should be at least equal in size and rating to the incoming power conductors. The internal earth bonding wire connects the PCBA earth terminal to the internal earth terminal in the enclosure back box.

External earthing connections should be made to the M5 earth stud, using a ring crimp terminal to secure the earth conductor to the earth stud. The external earth conductor should be at least 4mm² / AWG 11 in size.

Check that the earth bonding wire between the two castings is secure and the 'O' ring seal is in place and in good condition.

4.2 Maintenance, Repair and Overhaul

Maintenance, repair and overhaul of the equipment should only be carried out by suitably qualified personnel in accordance with the current relevant standards:

EN60079-19 / IEC60079-19 Explosive atmospheres - Equipment repair, overhaul and reclamation
 EN 60079-17/ IEC60079-17 Explosive atmospheres - Electrical installations inspection and maintenance

Units must not be opened while an explosive atmosphere is present.

If opening the unit during maintenance operations a clean environment must be maintained and any dust layer removed prior to opening the unit.

Electrostatic charging hazard - Clean only with a damp cloth

5) Installation

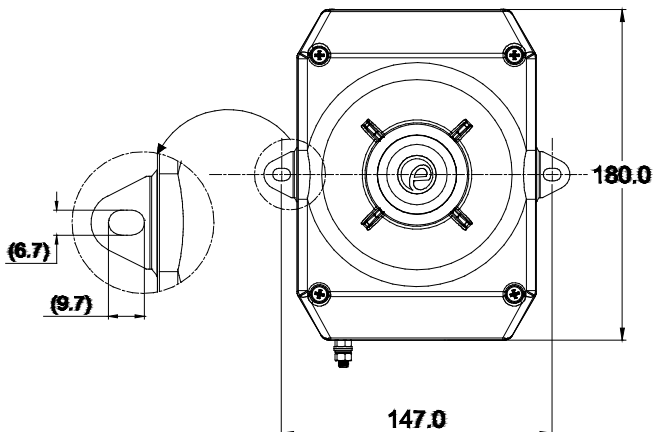

Fig. 1 Fixing locations.

D2xS1 alarm horn should only be installed by trained competent personnel.

5.1 Mounting

The D2xS1 alarm horn may be secured to any flat surface using the two 9.7 x 6.7mm, 147mm pitch fixing holes. The enclosure provides IP66 protection and is suitable for installation in exterior locations providing it is positioned so that water cannot collect in the horn, and the cable entry is sealed.

5.2 Installation procedure

- Remove Secure the D2xS1 alarm horn to a flat surface via the two 9.7 x 6.7mm, 147mm pitch fixing holes in the mounting feet.
- Remove the front of the alarm horn by unscrewing the four captive cover screws and pulling the front away from the enclosure.
- Fit an M20x1.5 suitably rated, certified cable gland or conduit entry into the hole in the enclosure and connect the field wiring to the appropriate alarm horn terminals as shown in section 9 and fig 8 (DC) or section 8 fig 5 (AC) of this manual. The power supply terminals are duplicated so that alarm horns may be connected in parallel and for DC units only an end of line monitoring resistor may be fitted. If the second M20x1.5 entry is not used a suitably rated, certified stopping plug must always be fitted.
- Select the required output tone by positioning the six switches as shown in Table 1 and Fig 2.
- Adjust the internal volume control to provide the required sound level. (Refer to section 6)
- Check that the O-ring seal in the front cover is in good condition and not damaged.
- Replace the front of the alarm horn and tighten the four captive cover screws.

6) Volume Control

The output level of the D2xS1 alarm horn can be set by adjusting the volume control potentiometer (see Fig 2). For maximum output, set the potentiometer fully clockwise.

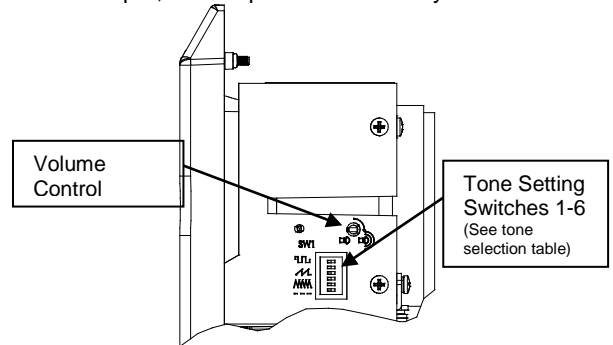

Fig. 2 Location of field controls

7) Cable Routing and Tone Selection

7.1 Cable Routing

Due to the compact design of the D2x units, it is important that the user strips off the outer sheath and biases any cables over the size of 1mm² as shown below.

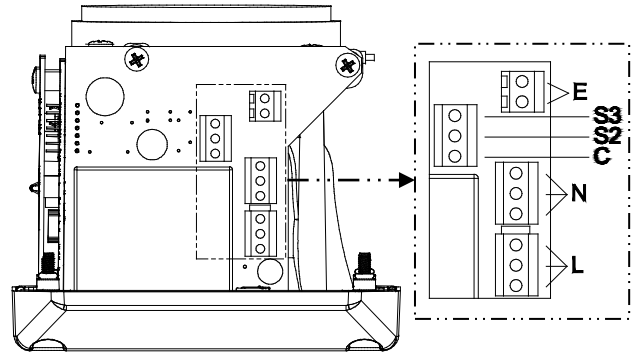
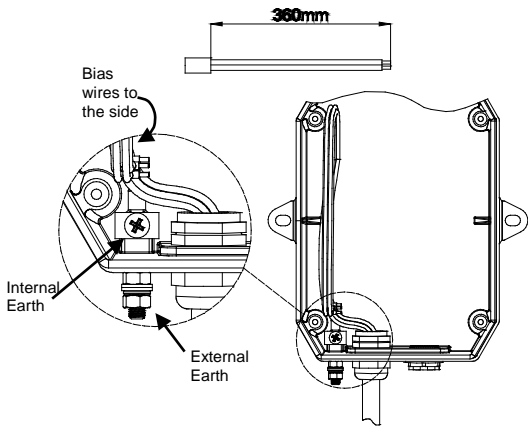
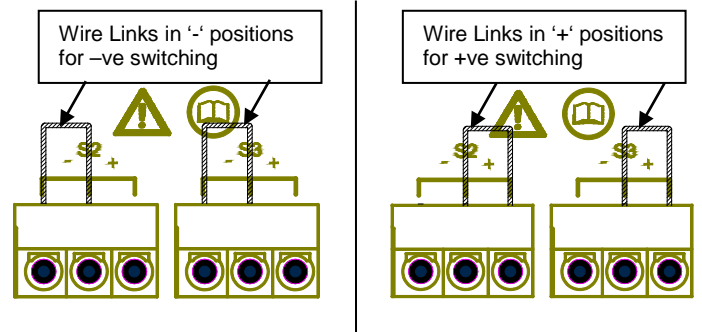

Fig. 5 AC Terminals

9) DC Wiring

9.1 DC Stage Polarity Control

The stage switches of the DC powered D2x units can be



activated via Positive (+ve) or Negative (-ve) switching. All units are factory set to -ve switching as standard. If +ve switching is required, the two wire links should be removed from the '-' positions of the stage polarity control terminals and fitted to the '+' positions as shown in fig 6.

Fig. 6 Stage Polarity Control settings.

9.2 Wiring Diagrams

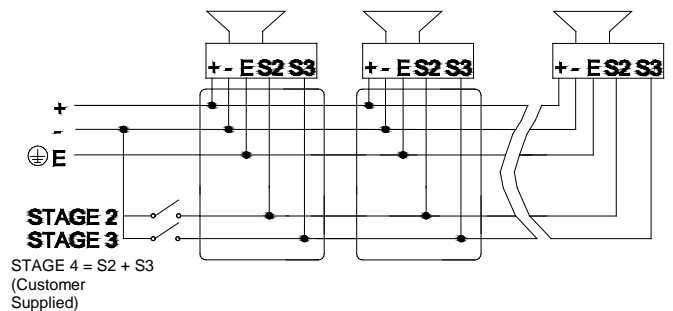

Fig. 7a DC Simplified Block Diagram (negative switching)

*Glands and/or stopping plugs to be customer supplied to suit application.

Fig 3. Cables are to be stripped and biased toward side of unit with allocated spacing as shown.

7.2 Tone Selection

The D2xS1 alarm horns have 64 different tones. The tones are selected by operation of the tone setting DIP switches (see Fig. 2) on the PCB. The alarm horns can also be switched to sound the second, third and fourth stage alarm tones. The tone table (Table 1) shows the switch positions for the 64 tone and which tones are available for the second, third and fourth stages.

8) AC Wiring

8.1 Wiring Diagram

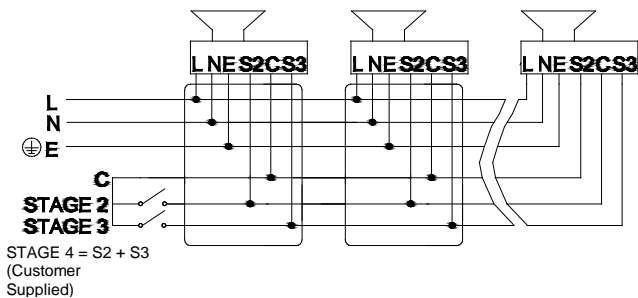

Fig 4. AC Simplified Block Diagram

8.2 Unit's First Stage Tones

Stage one (S1) operation: Simply connect the supply voltage to the L and N supply terminals, (see fig. 5).

8.3 AC Units Second, Third and Fourth Stage Tone Selection

To select the second, third and fourth stage tones on the D2xS1 AC alarm horns.

Stage two (S2) operation: Power L and N, link the common (C) and S2 terminal.

Stage three (S3) operation: Power L and N, link the common (C) and S3 terminals.

Stage four (S4) operation: Power L and N, link the common (C) and both the S2 and S3 terminals.

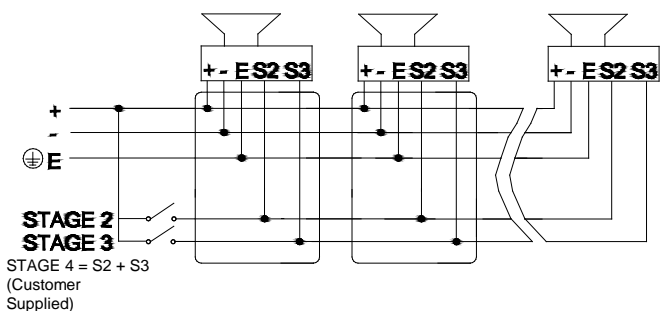

Fig. 7b DC Simplified Block Diagram (positive switching)

9.3 Unit's First Stage Tones

Stage one (S1) operation: Simply connect the supply voltage to the + and - supply terminals, (see fig. 8).

9.4 DC Units Second, Third and Fourth Stage Tone Selection

For units set up for -ve switching (default setting):

Stage two (S2) operation: Power +ve and -ve, link a -ve supply line to the S2 terminal.

Stage three (S3) operation: Power +ve and -ve, link a -ve supply line to the S3 terminal.

Stage four (S4) operation: Power +ve and -ve, link a -ve supply line to both the S2 & S3 terminals.

For units set up for +ve switching (refer to 9.1):

Stage two (S2) operation: Power +ve and -ve, link a +ve supply line to the S2 terminal.

Stage three (S3) operation: Power +ve and -ve, link a +ve supply line to the S3 terminal.

Stage four (S4) operation: Power +ve and -ve, link a +ve supply line to both the S2 & S3 terminals.

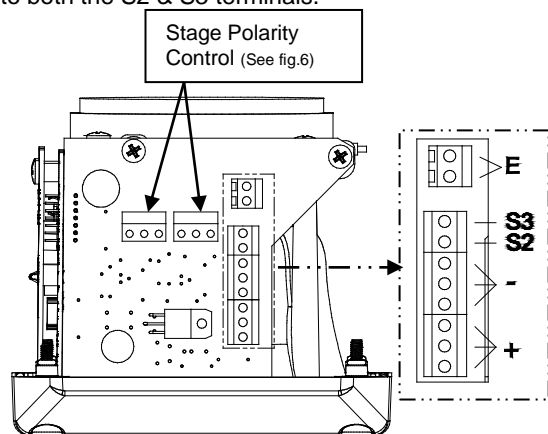

Fig. 8 DC Terminals

10) Earthing

The unit has both internal and external earth terminals, (please see fig 3).

Internal earthing connections should be made to the internal earth terminal on the PCBA, (please see fig 8 for DC, fig 5 for AC). The earth conductor should be at least equal in size and rating to the incoming power conductors. The internal earth bonding wire connects the PCBA earth terminal to the internal earth terminal in the enclosure back box.

External earth connections should be made to the M5 earth stud, using a ring crimp terminal to secure the earth conductor

to the earth stud. The external earth conductor should be at least 4mm² in size. The external earth crimp ring should be located between the two M5 plain washers provided and securely locked down with the M5 spring washer and M5 nut.

11) End Of Line Monitoring (DC Units Only)

On D2xS1 DC units, dc reverse line monitoring can be used if required. All DC alarm horns have a blocking diode fitted in their supply input lines. An end of line monitoring resistor can be connected across the +ve and -ve terminals. If an end of line resistor is used it must have the following values:-

24V DC Alarm horns

Minimum Resistance 3k9 ohms	Minimum wattage 0.5W
Minimum Resistance 1k ohms	Minimum wattage 2.0W

48V DC Alarm horns

Minimum Resistance 15k ohms	Minimum wattage 0.5W
Minimum Resistance 3k9 ohms	Minimum wattage 2.0W

The resistor must be connected directly across the +ve and -ve terminals as shown in the following drawing. Whilst keeping its leads as short as possible, a spacing of at least 1/16 inch (1.58mm) must be provided through air and over surfaces between uninsulated live parts.

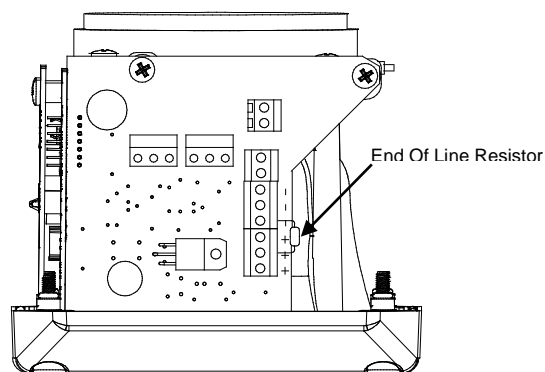
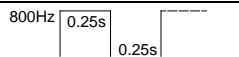

Fig. 9 End Of Line Resistor

Tone Selection – To select the required first stage tone set the tone switches 1 to 6 (see Fig 2) to the tone setting shown in the table below. The table also shows which 2nd, 3rd and 4th stage tones are available for use with the selected first stage tone if more than one tone output stage is required.

Stage 1 Tone No	Tone Description	Tone Visual	Switch Settings 1 2 3 4 5 6	Stage 2 Tone (S2)	Stage 3 Tone (S3)	Stage 4 Tone (S2 + S3)
1	1000Hz PFEER Toxic Gas		0 0 0 0 0	3	2	44
2	1200/500Hz @ 1Hz DIN / PFEER P.T.A.P.		1 0 0 0 0	1	3	44
3	1000Hz @ 0.5Hz(1s on, 1s off) PFEER Gen. Alarm		0 1 0 0 0	1	2	44
4	1.4KHz-1.6KHz 1s, 1.6KHz-1.4KHz 0.5s NF C 48-265		1 1 0 0 0	44	24	1
5	544Hz(100mS)/440Hz (400mS) NF S 32-001		0 0 1 0 0	52	19	1
6	1500/500Hz - (0.5s on , 0.5s off) x3 + 1s gap AS4428		1 0 1 0 0	7	44	1
7	500-1500Hz Sweeping 2 sec on 1 sec off AS4428		0 1 1 0 0	6	44	1
8	500/1200Hz @ 0.26Hz(3.3s on, 0.5s off) Netherlands - NEN 2575		1 1 1 0 0	44	24	35
9	1000Hz (1s on, 1s off)x7 + (7s on, 1s off) IMO Code 1a		0 0 0 1 0 0	18	34	1
10	1000Hz (1s on, 1s off)x7 + (7s on, 1s off) IMO Code 1a		1 0 0 1 0 0	21	34	1
11	420Hz(0.5s on, 0.5s off)x3 + 1s gap ISO 8201 Temporal Pattern		0 1 0 1 0 0	44	1	8
12	1000Hz(0.5s on, 0.5s off)x3 + 1s gap ISO 8201 Temporal Pattern		1 1 0 1 0 0	44	1	8
13	422/775Hz - (0.85 on, 0.5 off) x3 + 1s gap NFPA - Temporal Coded		0 0 1 1 0 0	44	1	8
14	1000/2000Hz @ 1Hz Singapore		1 0 1 1 0 0	23	3	35
15	300Hz Continuous		0 1 1 1 0 0	44	24	35
16	440Hz Continuous		1 1 1 1 0 0	44	24	35
17	470Hz Continuous		0 0 0 0 1 0	44	24	35
18	500Hz Continuous IMO code 2 (Low)		1 0 0 0 1 0	44	24	35
19	554Hz Continuous		0 1 0 0 1 0	64	24	35
20	660Hz Continuous		1 1 0 0 1 0	44	24	35
21	800Hz IMO code 2 (High)		0 0 1 0 1 0	44	24	35
22	1200Hz Continuous		1 0 1 0 1 0	44	24	35
23	2000Hz Continuous		0 1 1 0 1 0	15	3	35
24	2400Hz Continuous		1 1 1 0 1 0	48	20	35
25	440 @ 0.83Hz (50 cycles/minute) Intermittent		0 0 0 1 1 0	1	44	8
26	470 @ 0.9Hz - 1.1s Intermittent		1 0 0 1 1 0	1	44	8
27	470Hz @ 5Hz - (5 cycles/second) Intermittent		0 1 0 1 1 0	1	44	8
28	544Hz @ 1.14Hz - 0.875s Intermittent		1 1 0 1 1 0	44	24	8
29	655Hz @ 0.875Hz Intermittent		0 0 1 1 1 0	1	44	8
30	660Hz @ 0.28Hz - 1.8sec on, 1.8sec off Intermittent		1 0 1 1 1 0	44	24	8
31	660Hz @ 3.34Hz - 150mS on, 150mS off Intermittent		0 1 1 1 1 0	30	24	8

32	745Hz @ 1Hz Intermittent		1 1 1 1 1 0	44	24	8
33	800Hz - 0.25sec on, 1 sec off Intermittent		0 0 0 0 0 1	53	24	8
34	800Hz @ 2Hz IMO code 3.a (High) Intermittent		1 0 0 0 0 1	56	24	8
35	1000Hz @ 1Hz Intermittent		0 1 0 0 0 1	44	24	8
36	2400Hz @ 1Hz Intermittent		1 1 0 0 0 1	21	24	8
37	2900Hz @ 5Hz Intermittent		0 0 1 0 0 1	53	24	8
38	363/518Hz @ 1Hz Alternating		1 0 1 0 0 1	1	8	19
39	450/500Hz @ 2Hz Alternating		0 1 1 0 0 1	1	8	19
40	554/440Hz @ 1Hz Alternating		1 1 1 0 0 1	44	24	19
41	554/440Hz @ 0.625Hz Alternating		0 0 0 1 0 1	1	8	19
42	561/760Hz @ 0.83Hz (50 cycles/minute) Alternating		1 0 0 1 0 1	1	8	19
43	780/600Hz @ 0.96Hz Alternating		0 1 0 1 0 1	1	8	19
44	800/1000Hz @ 2Hz Alternating		1 1 0 1 0 1	5	24	19
45	970/800Hz @ 2Hz Alternating		0 0 1 1 0 1	1	8	19
46	800/1000Hz @ 0.875Hz Alternating		1 0 1 1 0 1	53	24	19
47	2400/2900Hz @ 2Hz Alternating		0 1 1 1 0 1	57	24	19
48	500/1200Hz @ 0.3Hz Sweeping		1 1 1 1 0 1	44	24	12
49	560/1055Hz @ 0.18Hz Sweeping		0 0 0 0 1 1	44	24	12
50	560/1055Hz @ 3.3Hz Sweeping		1 0 0 0 1 1	44	24	12
51	600/1250Hz @ 0.125Hz Sweeping		0 1 0 0 1 1	44	24	12
52	660/1200Hz @ 1Hz Sweeping		1 1 0 0 1 1	64	24	12
53	800/1000Hz @ 1Hz Sweeping		0 0 1 0 1 1	56	24	12
54	800/1000Hz @ 7Hz Sweeping		1 0 1 0 1 1	57	24	12
55	800/1000Hz @ 50Hz Sweeping		0 1 1 0 1 1	54	24	12
56	2400/2900Hz @ 7Hz Sweeping		1 1 1 0 1 1	57	24	12
57	2400/2900Hz @ 1Hz Sweeping		0 0 0 1 1 1	47	24	12
58	2400/2900Hz @ 50Hz Sweeping		1 0 0 1 1 1	54	24	12
59	2500/3000Hz @ 2Hz Sweeping		0 1 0 1 1 1	44	24	12
60	2500/3000Hz @ 7.7Hz Sweeping		1 1 0 1 1 1	44	24	12
61	800Hz Motor Siren		0 0 1 1 1 1	44	24	12
62	1200Hz Motor Siren		1 0 1 1 1 1	44	24	12
63	2400Hz Motor Siren		0 1 1 1 1 1	44	24	12
64	Simulated Bell		1 1 1 1 1 1	44	21	12