



▶ Model 450EWBX

## Vibratone® Hazardous Location Electronic Horn

Offers a corrosion resistant and weatherproof housing

Model 450EWBX hazardous location electronic horn offers a patent pending electronic design that produces a very loud, clear and distinctive electronic tone. The model is capable of producing sustained tones or coded blasts through push button or PLC control devices without a duty cycle or interval limitations.

The 450EWBX is ideal for general alarm, start and dismissal, coded paging and process control signaling in areas of high ambient noise levels.

### FEATURES

- Rated for Class I, Division 2; Class II, Division 2; Class III
- No duty cycle
- Four wire terminal block and supervisory diode
- No detectable RF emissions in a 30-1000 MHz frequency range
- NEMA Type 4X
- Marine Rated
- UL and cUL Listed
- 450E Horn is UL and ULC Listed for Fire Alarm Use

MODEL	VOLTAGE	OPERATING CURRENT	DECIBELS @	
			10'	1M
<b>450EWBX-024</b>	24VDC	0.22 amps	99	109
	12VDC	0.12 amps	94	104

Hazardous Location Rating:

T-CODE AT MAXIMUM AMBIENT TEMPERATURE, °C		
HAZARDOUS LOCATION	40 °C	70 °C
CID2, Groups A, B, C & D	T4A	T3C
CIID2, Groups F & G	T5	T4A
CIII	T5	T4A

Vibratone® Hazardous Location Electronic Horn (450EWBX)

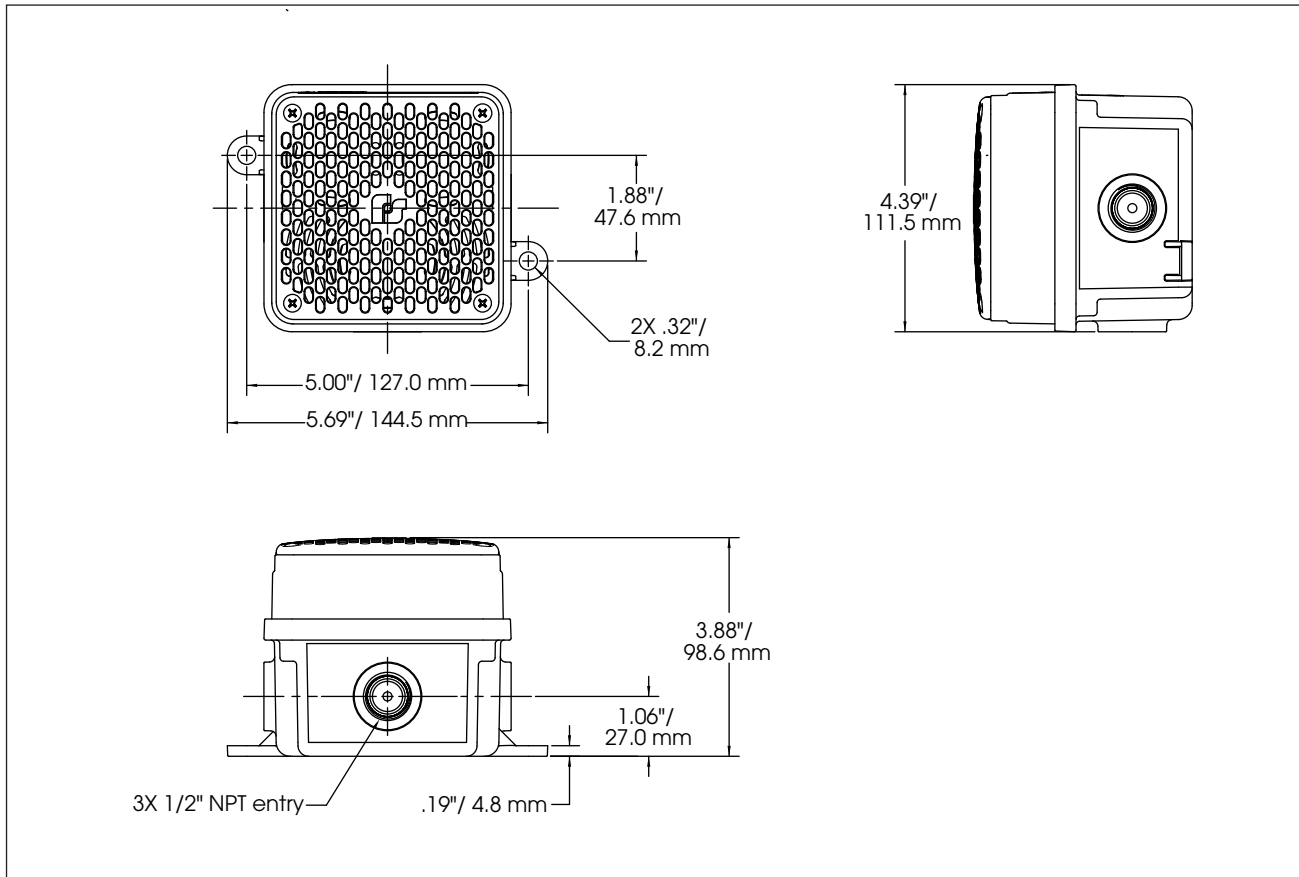

**S P E C I F I C A T I O N S**

Operating Temperature:	-65°F to 150°F	-54°C to 66°C
Housing:	Non-metallic Polycarbonate Light Gray (RAL 7035)	
Speaker Cone:		Polymeric
Net Weight:	2.3 lbs	1.04 kg
Height:	4.39"	111.5 mm
Width:	4.39"	111.5 mm
Depth:	3.88"	98.6 mm

**H O W T O O R D E R**

- Specify Model:  
**450EWBX-024** – Electronic Horn,  
 Hazardous Location, 12/24VDC

