

# D1xL2F PA Loudspeakers 25W

The D1xL2F is a 25W PA loudspeaker with re-entrant flare horn. A high SPL in a robust Type 4/4X, IP66 marine grade, corrosion proof aluminium enclosure ensures suitability for all Class I & II Div 1 & Zone 1/20 explosion proof applications.

The re-entrant flare horn is high impact, fire retardant ABS and is field replaceable – the driver employs a standard 1 3/8" -18 male thread coupling. All models have triple cable entries, and large termination areas.

The termination chamber and cover feature a threaded flameproof joint simplifying both installation and routine maintenance.

## Features

- High output
- Compact form factor
- Multiple transformer tapings
- Field replaceable flare component
- Robust corrosion proof aluminium enclosure
- Ratchet adjustable stainless steel bracket
- Stainless steel fixings
- Triple cable entries
- Duplicate cable terminations
- Threaded cover joint for fast installation

## Approvals

- UL File ref: E230764  
UL 1203 Ed. 5  
CAN/CSA C22.2 No. 25-1966  
CSA C22.2 No. 30-M1986  
CSA C22.2 No. 205-12  
UL 1480 Ed. 6  
Commercial and professional use
- CSFM listing: 7136-2279:0504

## Coding

- A1: Gas version  
NEC / CEC:  
Class I Div 1 ABCD T6 Ta -40°C to +70°C  
Class I Div 2 ABCD T6 Ta -40°C to +70°C  
Class I Zone 1, 2 IIC T6 Ta -40°C to +70°C
- D1: Dust version  
NEC / CEC:  
Class II Div 1 FG T6 Ta -40°C to +70°C  
Class II Div 2 FG T6 Ta -40°C to +70°C  
Class III Div 1 & 2  
Zone 20, 21, 22 IIIB Ta -40°C to +70°C
- Protection concept: Ex d / AEx d



THE  
**SIGNAL SOURCE**<sup>®</sup>  
Industry's Source FOR Signaling Solutions™

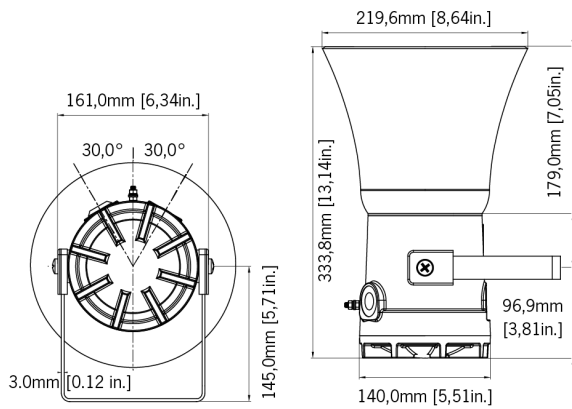

## Specification

SPL (Gas version):	104dB +/-3dB @ 1W @ 1m (Pink) 118dB +/-3dB @ 25W @ 1m (Rated)
SPL (Dust version):	83dB +/-3dB @ 1W @ 1m (Pink) 97dB +/-3dB @ 25W @ 1m (Rated)
Rated power:	25 Watts RMS
70v line tapings:	25W/12.5W/6W/2W tapings (z=196 Ohms/392 Ohms/816.67 Ohms/2.45k Ohms)
Low impedance:	8 Ohm or 16 Ohm
Directivity Index:	7.6 @ 1kHz & 17.6 @ 4kHz [dB on-axis]
Frequency range:	300Hz to 8000 Hz
DC Line monitoring:	2.2µF Capacitor (Transformer ) 470µF Capacitor (Low impedance)
Ingress protection:	EN60529: IP66 UL50E / NEMA250: 4 / 4X / 3R / 13
Enclosure material:	Marine grade aluminium LM6-copper free Chromated & powder coated – corrosion proof
Colour:	Red (RAL3000), Grey (RAL7038)
Cable entries:	1 × 1/2"NPT & 2 × M20 x 1.5mm 1 × 1/2"NPT & 2 × 1/2"NPT 1 × 1/2"NPT & 2 × 3/4"NPT
Terminals:	0.5 – 2.5mm <sup>2</sup> (20-14 AWG)
Grounding stud:	M5
Operating temp:	-40° to +70°C [-40° to +158°F]
Storage temp:	-50° to +70°C [-58° to +158°F]
Relative humidity:	95% – Additional tropicalisation is recommended for applications where both high relative humidity and high ambient temperatures exist
Weight:	70V line: 4.5kg/9.9lbs Low imp.: 4.2kg/9.1lbs

## Part Codes

Version:	Part code: _____	
Product type:	D1xL2	
Horn type:	F	Flare re-entrant horn
Type:	V070	70V Line Transformer
	R008	8 Ohm Low impedance
	R016	16 Ohm Low impedance
Cable Entry Type:	A	1 × 1/2"NPT & 2 × M20 x 1.5mm
[e]	B	1 × 1/2"NPT & 2 × 1/2"NPT
	C	1 × 1/2"NPT & 2 × 3/4"NPT
Adaptor/Stopping plug material: [m]	B	Brass
	N	Nickel Plated
	S	Stainless Steel
Bracket matl & tag: [s]	1	A2 304 Stainless Steel
	2	A4 316 Stainless Steel
	3	A2 304 St/St with Equip. Tag
	4	A4 316 St/St with Equip. Tag (304)
Product version: [v]	A1	Gas environments Class I/Zone1
	D1	Dust environments Class II/Zone 20
Enclosure colour: [x]	G	Grey RAL7038
	R	Red RAL3000
Accessories:	SP65-0001-A2	Pole Mount Bracket Kit 2" St/St A2 (304)
	SP65-0001-A4	Pole Mount Bracket Kit 2" St/St A4 (316)
	SP65-0003-A2	Sunshade – St/St A2 (304)
	SP65-0003-A4	Sunshade – St/St A4 (316)