



► Model 450E

Vibratone® Electronic Horn

Designed for routine signaling and fire alarm use

Model 450E electronic horn offers a loud, clear and distinctive tone. It's often used for general alarming, start and dismissal noticing, coded paging and process control in noisy areas. Its 4-wire terminal block and supervisory diodes design make it ideal for fire alarm applications.

The 450E's polycarbonate housing and polymeric speaker are corrosion resistant and weatherproof for improved durability in harsh industrial environments. It has no detectable RF emissions in a 30 MHz to 1000 MHz frequency range, which minimizes the potential for electrical device interference.

FEATURES

- Fire Regulated 16-33VDC
General Purpose Signal 12-24VDC
- User supplied coded or sustained tones
- No duty cycle or interval limitations
- 99dBA at 10' on axis
- Four wire terminal block and supervisory diode
- Type 4X when installed with Panel Mount Gasket (included) or optional Non-metallic Weatherproof Backbox (Model WB-NM)
- Marine Rated
- UL, cUL and ULC Listed
- CSFM Listed

MODEL	VOLTAGE	OPERATING CURRENT	DECIBELS UL 464		DECIBELS ON AXIS	
			@ 10'	1 M	10'	1 m
450E-024	Fire Regulated 16-33VDC	0.25 amps	90	109	99	109
	General Purpose Signal 24VDC	0.22 amps	N/A	N/A	99	109
	General Purpose Signal 12VDC	0.12 amps	N/A	N/A	94	104

Vibratone® Electronic Horns (450E)

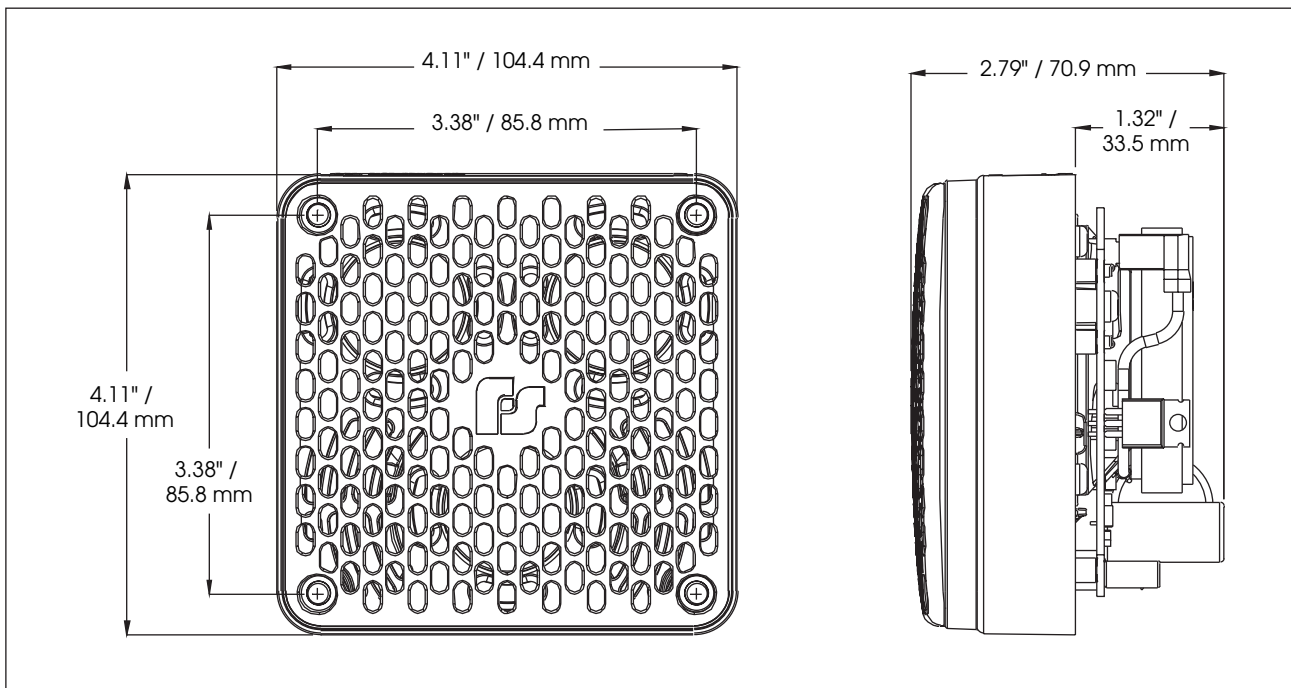

S P E C I F I C A T I O N S

Operating Temperature:	-65°F to 150°F	-54°C to 66°C
Housing	Non-metallic Polycarbonate Light Gray (RAL 7035)	
Net Weight:	1.0 lbs.	0.45 kg
Shipping Weight:	1.3 lbs.	0.59 kg
Height:	4.11"	104.4 mm
Width:	4.11"	104.4 mm
Depth:	2.79"	70.9 mm

H O W T O O R D E R

- Specify Model:
450E-024 – Vibratone® Electronic Horns
- Specify accessories from list

• Optional Accessories

FB – Wall box for flush mounting the Vibratone® horn in stud, 4" block, or other shallow wall construction; 4-3/8" square box; 2-7/8" deep; shipping weight 2 lbs. (0.91 kg)

FBL – Same as FB, but 3-13/16" deep for 6" x 8" concrete block, cinder block or other deep wall construction; shipping wt. 3 lbs. (1.36 kg)

FG – Flush grille which attaches to the basic unit and serves as the cover of the plastered-in FB flush box; 6" H x 6" W x 1/8" D; shipping wt. 1 lb. (0.45 kg)

PR2-NM – Non-metallic double projector directs sounds to both sides when attached to 350/450E models; ideal for use in hallways; 4" H x 11-1/2" W x 4" D; shipping weight 1 lb (0.45kg)

WB-NM – Molded thermoplastic neoprene-gasketed weatherproof housing for outside use, complete with mounting lugs; provided with (3) entrances for 1/2" conduit; 4-3/8" square box; 2-7/16" deep, offset mounting lugs on 5" centers; shipping weight 1 lb (0.45kg)



450E shown with included panel mount gasket



WB-NM



Rev. 021816