



▶ Model 350

Vibratone® Horns

Designed for routine signaling

Model 350 Vibratone® Horn produces a loud tone by the electro-mechanical vibration of a diaphragm. Its compact size, loud output and heavy-duty construction makes the 350 ideal for industrial and institutional signaling applications. It's popularly used for general alarming, start and dismissal noticing, coded paging and process control in noisy areas.

The 350 is enclosed in a zinc die-cast housing and sealed with grey powder-coat paint with a stainless steel diaphragm.

FEATURES

- User supplied coded or sustained tones
- Produces 100dBA at 10'
- Type 4X when installed with Panel Mount Gasket Kit or Weatherproof Backbox (Model WB); Type 4X and Type 12 when installed with Surface Mount Trim Ring (Model TR)
- UL and cUL Listed, CSA Certified and FM Approved
- Surface or flush mounting options
- Available in – 12, 24, 120 and 240VAC

MODEL	VOLTAGE	OPERATING CURRENT	DECIBELS	
			@ 10'	1 M
350-012-30	12VAC 50/60Hz	0.90 amps	94	104
350-024-30	24VAC 50/60Hz	0.90 amps	100	110
350-120-30	120VAC 50/60Hz	0.18 amps	100	110
350-240-30	240VAC 50/60Hz	0.09 amps	100	110

Vibratone® Horns (350)

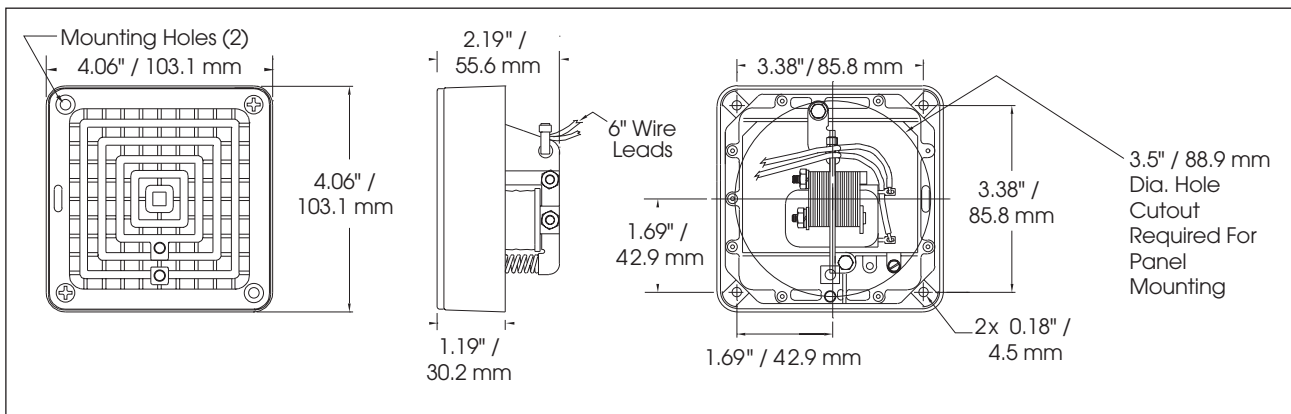

S P E C I F I C A T I O N S

Operating Temperature:	-65°F to 150°F	-54°C to 66°C
Net Weight:	1.4 lbs.	0.6 kg
Shipping Weight:	1.5 lbs.	0.7 kg
Height:	4.06"	103.1 mm
Width:	4.06"	103.1 mm
Depth:	2.19"	55.6 mm

H O W T O O R D E R

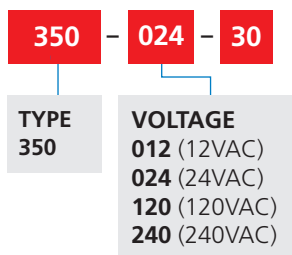

R E P L A C E M E N T P A R T S

Description	Part Number
Panel Mount Gasket Kit	K8435666A
Volume Control Kit	K8435663B
Coil, 120VAC	KFC1516C
Coil, 240VAC	KFC1506C

- Specify model number and voltage
- Specify accessories from list

• Optional Accessories

FB – Wall box for flush mounting the Vibratone® horn in stud, 4" block, or other shallow wall construction; 4-3/8" square box; 2-7/8" deep; shipping weight 2 lbs. (0.91 kg)

FBL – Same as FB, but 3-13/16" deep for 6" x 8" concrete block, cinder block or other deep wall construction; shipping wt. 3 lbs. (1.36 kg)

FG – Flush grille which attaches to the basic unit and serves as the cover of the plastered-in FB flush box; 6" H x 6" W x 1/8" D; shipping wt. 1 lb. (0.45 kg)

K8435666A – Optional Panel Mounting Gasket Kit includes a gasket and hardware for surface or flush mounting the horn for NEMA Type 4X applications.

PR2-NM – Non-metallic double projector directs sounds to both sides when attached to 350/450E models; ideal for use in hallways; 4" H x 11-1/2" W x 4" D; shipping weight 1 lb (0.45kg)

SF – Stamped surface plate used for installations on plastered-in 4" outlet switch boxes for semi-flush mountings; 6" H x 6" W x 1/2" D; shipping weight 1 lb. (0.45 kg)

TR – Gasketed trim ring allowing surface mount installations of unit while maintaining Type 12 and Type 4X rating of enclosure.

WB-NM – Cast aluminum neoprene-gasketed weatherproof housing for outside use, complete with mounting lugs; tapped for 1/2", 3/4" conduit; 4-3/8" square box; 2" deep mounting lugs on 4-1/2" centers; shipping weight 1 lb. (0.45 kg)

WB-NM

