

Further Information

Diameter (d)	Pitch	d2 (max)	k (max)	s (nom)	t (min)	c
M2	0.40	4.0	1.23	1.3	*	*
M2.5	0.45	5.5	1.43	1.5	*	*
M3	0.50	7.0	1.70	2.0	1.05	0.7
M4	0.70	9.4	2.20	2.5	1.3	0.8
M5	0.80	11.6	2.80	3.0	1.56	1.0
M6	1.00	13.6	3.30	4.0	2.08	1.1
M8	1.25	17.8	4.40	5.0	2.6	1.5
M10	1.50	22.0	5.50	6.0	3.12	1.7
M12	1.75	25	7.00	8.0	4.16	2.4

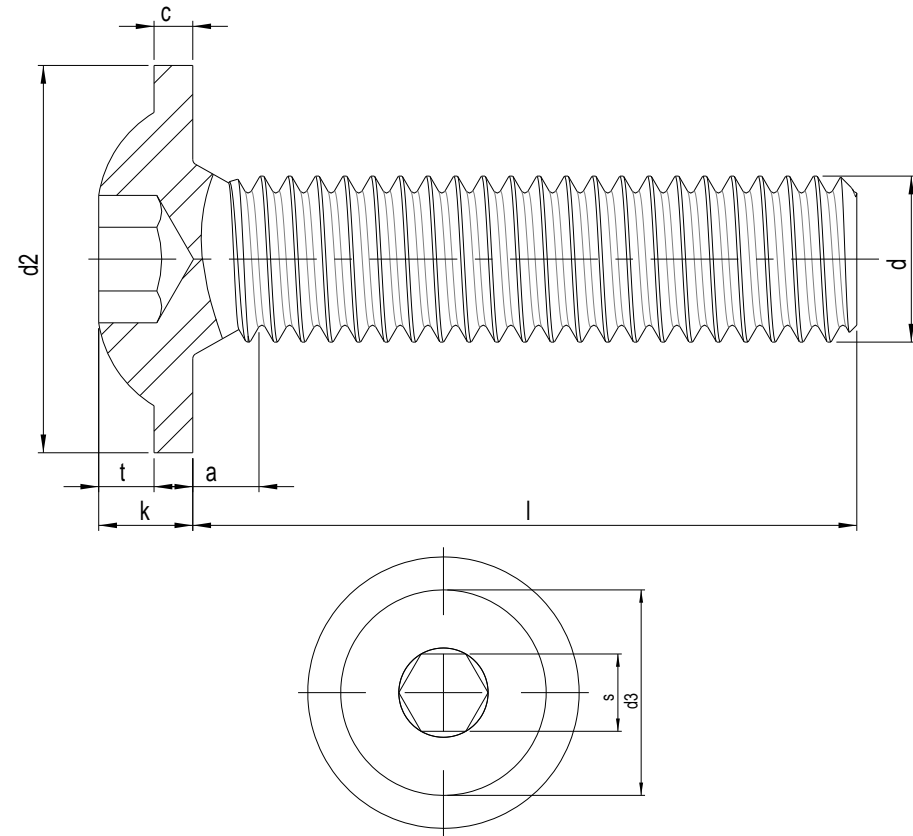

BoltWorld
lets bring things together.....

FLANGED SOCKET
BUTTON ISO 7380-2

Information in this drawing is provided for reference only